

**AAE Model No. AFP-22/H**  
**22' All-Aluminum Hinged Fair Pole**

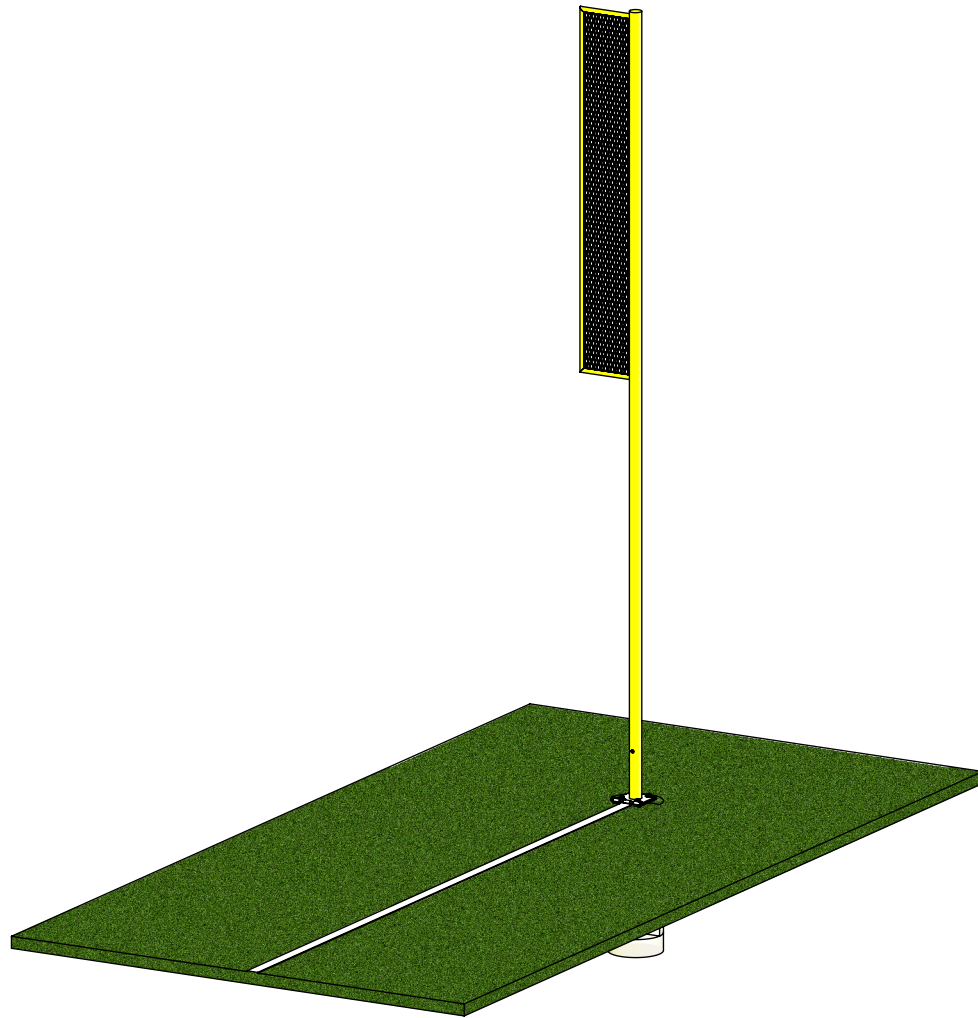

**Aluminum Athletic Equipment**  
1000 Enterprise Drive, Royersford, PA 19468  
Toll Free: (800) 523-5471 Fax: (610) 825-2378  
[www.AAEsports.com](http://www.AAEsports.com)

# AFP-22/H Specifications

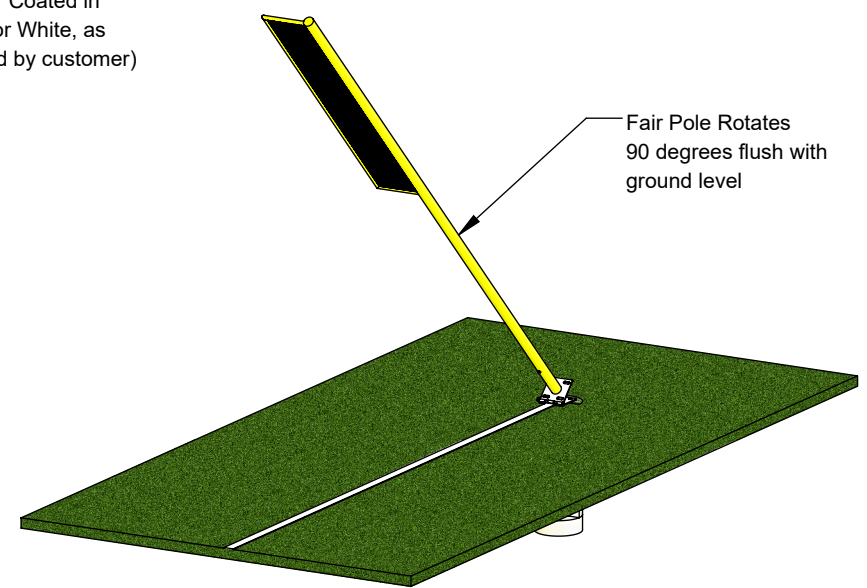
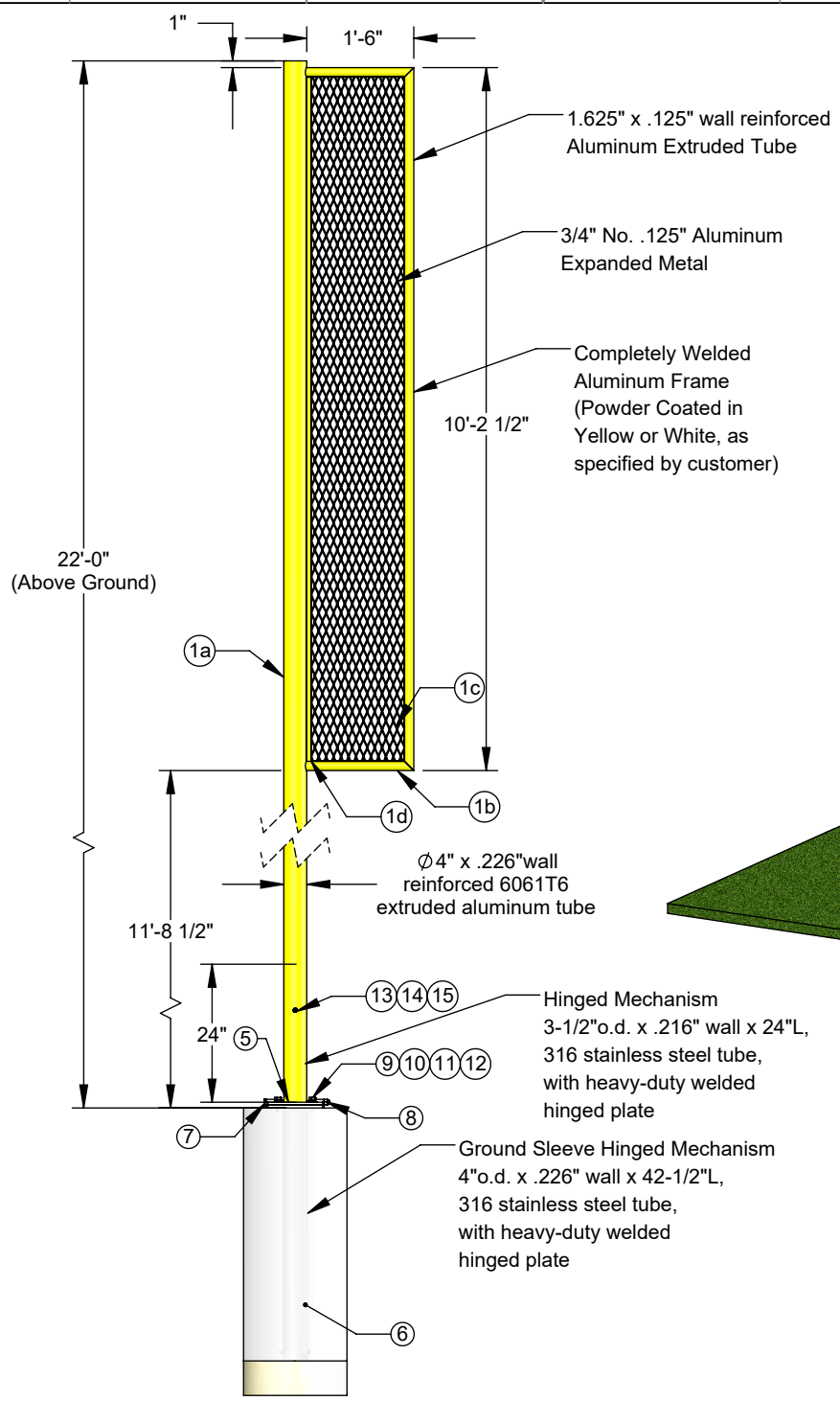
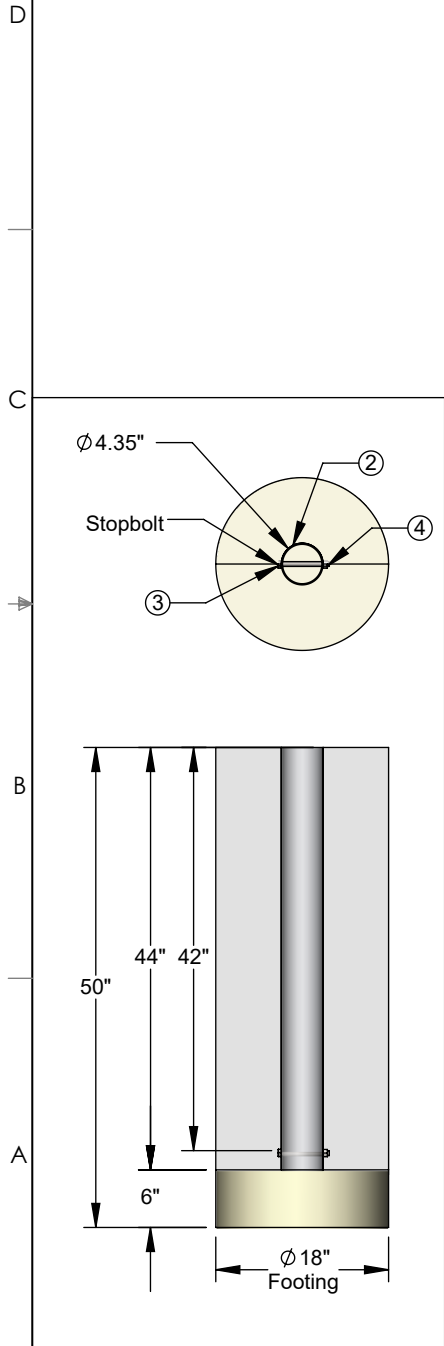

**\*\*Fair Poles available in both Yellow & White\*\***

 <b>Aluminum Athletic Equipment</b> 1000 Enterprise Drive, Royersford, PA 19468 Toll Free: (800) 523-5471 Fax: (610) 825-2378 <a href="http://www.AAEsports.com">www.AAEsports.com</a>		
DESCRIPTION:		
<b>AFP-22/H - All-Aluminum Fair Pole - Hinged</b>		
NOTE:		
Hinged Welded Aluminum Fair Pole		
MODEL:	CATEGORY:	DATE:
AFP-22/H	<b>CUSTOMER</b>	10/24/2019
DWN. BY:	CAD FILE:	DWG. NO.:
CED	AFP-22/H Specifications	AFP-22/H-C-002

**Installation**

The stopbolt located at the bottom of the ground sleeve must be positioned so that it is perpendicular to the third or first base line. (See diagram below)

The ground sleeve must be oriented in this manner in order for your fair pole to fit properly.

Any questions, please call 800-523-5471

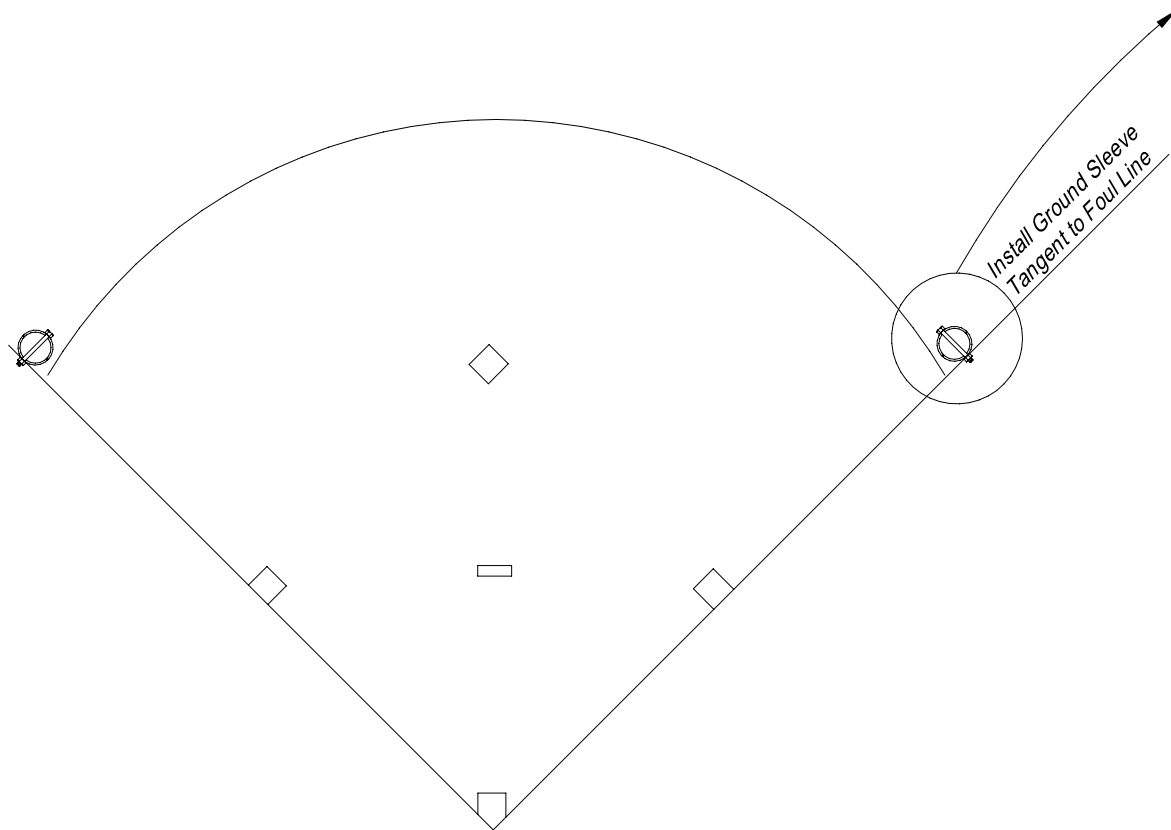

**GROUND SLEEVE**

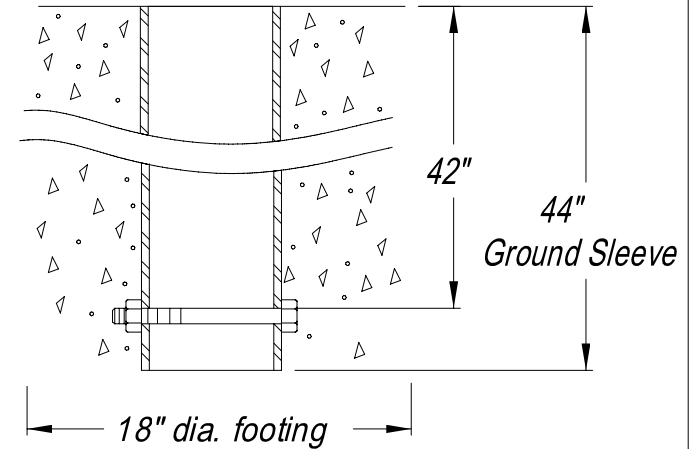
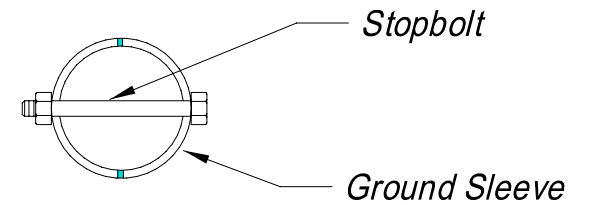

**AAE** ALUMINUM  
ATHLETIC  
EQUIPMENT  
1000 Enterprise Drive, Royersford, PA 19468  
Phone: (610)-825-6565 Toll-free: 1-800-523-5471

<b>DESCRIPTION</b> <b>FAIR POLE GROUND SLEEVE LOCATION</b>		
MODEL NO.	ITEM	DATE: 3/2/06
DWN. BY:	REV.	DWG. NO. AAE-248b

**AFP-22/H**  
**22' ALL-ALUMINUM HINGED FAIR POLE**  
**PARTS LIST**

<b>Pt. #</b>	<b>Item</b>	<b>Description</b>	<b>Qty.</b>
1a	Fair Pole	4" o.d. x 22'-0" overall x .226" wall reinforced 6061T6 extruded aluminum tube (22' out of ground)	2
1b	Frame	1.625" od. x .125 wall extruded aluminum tube, 1'-6" x 10'-2 1/2" welded frame	2
1c	Wire Mesh	3/4" No. .125" thick aluminum expanded metal	2
1d	Net Clip Extrusion	2" Radius x .125" wall aluminum extrusion	2
2	Ground Sleeve	Ground Sleeve, 4.350" o.d. x .100 wall x 44" long	2
3	Hex bolt	1/2"-13 x 5" hex head bolt, plated	2
4	Nut	1/2"-13 wiz-lock nut, plated	2
5	Hinged Mechanism	3-1/2" o.d. x .216" wall x 24" long, 316 stainless steel tube with heavy-duty welded hinged plate	2
6	Ground Sleeve Hinged Mechanism	4" o.d. x .226" wall x 42-1/2" long, 316 stainless steel tube with heavy-duty welded hinged plate	2
7	Hex bolt	5/8"-11 x 11" hex head bolt, stainless steel	2
8	Nut	5/8"-11 nylon lock nut, stainless steel	2
9	Hex bolt	5/8"-11 x 2" hex head bolt, stainless steel	8
10	Loc washer	5/8" Loc washer, stainless steel	8
11	Flat Washer	5/8" Flat washer, stainless steel	8
12	Nut	5/8"-11 Nut, stainless steel	8
13	Hex bolt	3/8"-16 x 4-1/2" hex head bolt, stainless steel	2
14	Flat Washer	3/8" Flat washer, stainless steel	2
15	Nut	3/8"-16 wiz-lock nut, stainless steel	2

**FOR TECHNICAL ASSISTANCE, CALL 1-800-523-5471**

K:\AAE Data\PDF Files\Product Instructions & Parts Lists\Baseball\AFP-22\_H\AFP-22\_H Parts List.doc  
 Copyright © 2003 Aluminum Athletic Equipment Co.

**AFP-22/H**  
**22' ALL-ALUMINUM HINGED FAIR POLE**  
**INSTALLATION INSTRUCTIONS**

---

**INSTALLATION:** (Refer to drawing No. AAE-248b for details)

1. Locate the location for the ground sleeves to be installed in the outfield tangent to the foul line, hugging the inside of the field. Drill or dig an 18" diameter hole, a minimum of 50" deep (Consult local codes for concrete depth) at the center of the location of the ground sleeves to be installed. Fill the hole with 6" of crushed stone.
2. Insert the ground sleeves, ("bolt" side down) in the center of the hole. Make sure the ground sleeves are flush with the ground, leveled and plumb. Also, rotate the ground sleeves so that the stopbolt in the ground sleeve is in the correct orientation to the foul line. (See Dwg. No. AAE-248b)

NOTE: It is extremely important that the stopbolts in the ground sleeve are in proper alignment, so the keyslot in the main upright will lock the upright into it's proper position when set into the ground sleeve.

3. When the ground sleeves are in the proper position and alignment, the concrete can be poured. (Be sure not to get any concrete inside the ground sleeves!) As the concrete cures, constantly check to see that the ground sleeves are flush with the ground, centered, plumb, and in the correct alignment. (A piece of 4" PVC pipe with a Post Level inserted into the ground sleeve may be used to maneuver the position of the sleeve if needed)
4. Lower the hinged ground sleeve mechanism into the ground sleeve, making sure that the notch in the bottom of the sleeve sets onto the stopbolt.
5. Attach fair pole to the out of ground hinged mechanism and raise fair pole into position, once raised use supplied bolts and washers to anchor both hinged mechanisms together.

**FOR TECHNICAL ASSISTANCE, CALL 1-800-523-5471**