

Model No.: ASG-NCAA
6' Offset College Football Goal

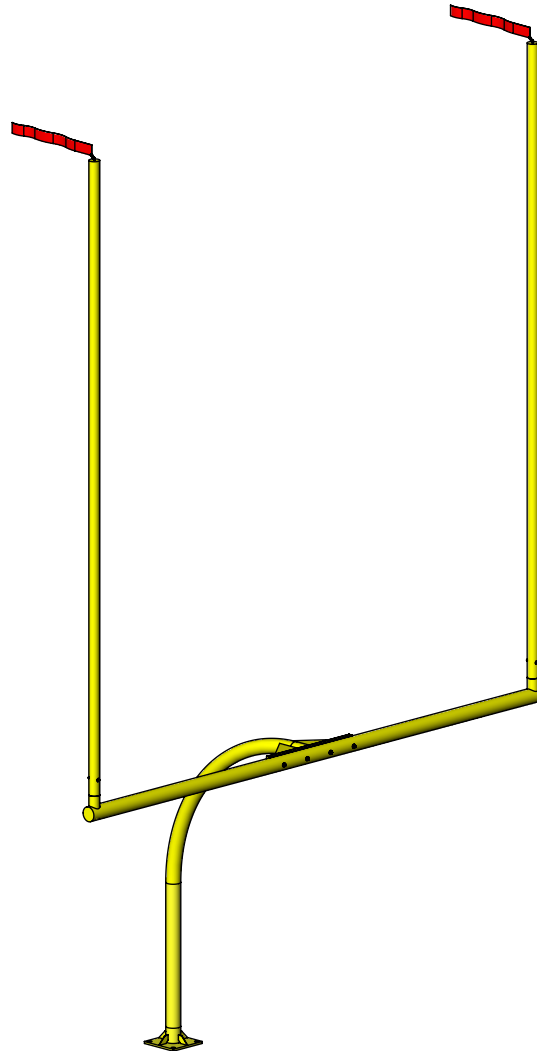

Aluminum Athletic Equipment
1000 Enterprise Drive, Royersford, PA 19468
Toll Free: (800) 523-5471 Fax: (610) 825-2378
www.AAEsports.com

ASG-NCAA - 6' Offset Football Goal

Specifications

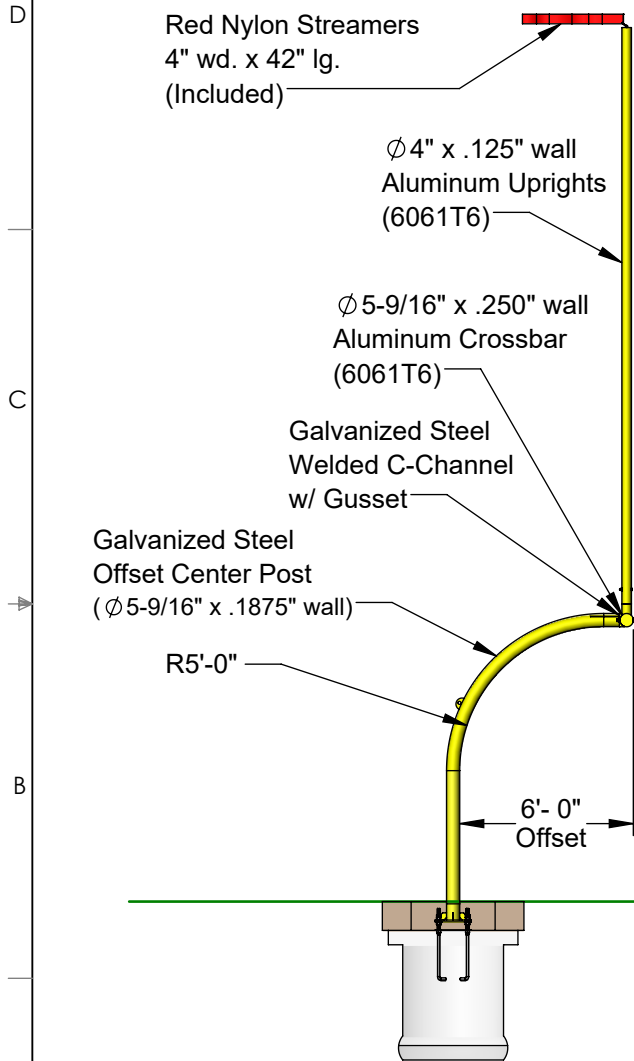

SIDE VIEW

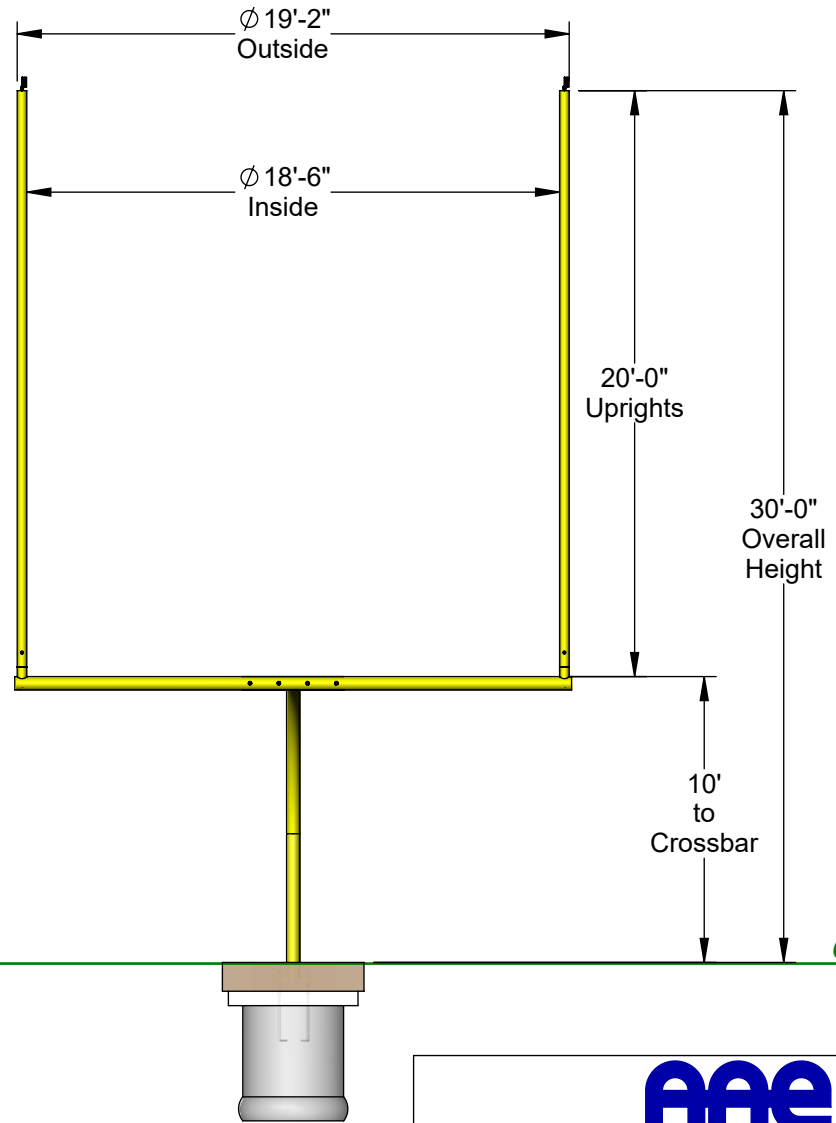

FRONT VIEW

*** The Entire Goal is Powder-coated White or Yellow Customer's Choice.**



Aluminum Athletic Equipment
1000 Enterprise Drive, Royersford, PA 19468
Toll Free: (800) 523-5471 Fax: (610) 825-2378
www.AAEsports.com

DESCRIPTION:		
ASG-NCAA, 6' Offset Football Goal		
NOTE:		
Specifications		
MODEL:	CATEGORY:	DATE:
ASG-NCAA	CUSTOMER	5/18/2021
DWN. BY:	CAD FILE:	DWG. NO.:
CED	ASG-NCAA, 6' Offset Specifications	ASG-NCAA-C-001

ASG-NCAA - 6' Offset Football Goal Template Installation

D

Exact center of Foundation Plate

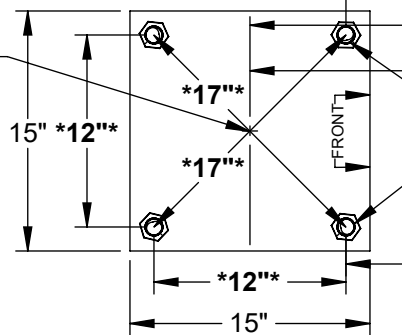

IMPORTANT!!

These front anchor bolts must be parallel with the goal line!!

5'-8"

186'-2" to 50 yard line

6'-2"

5'-8"

4" Wide End Zone Line

C

D

C

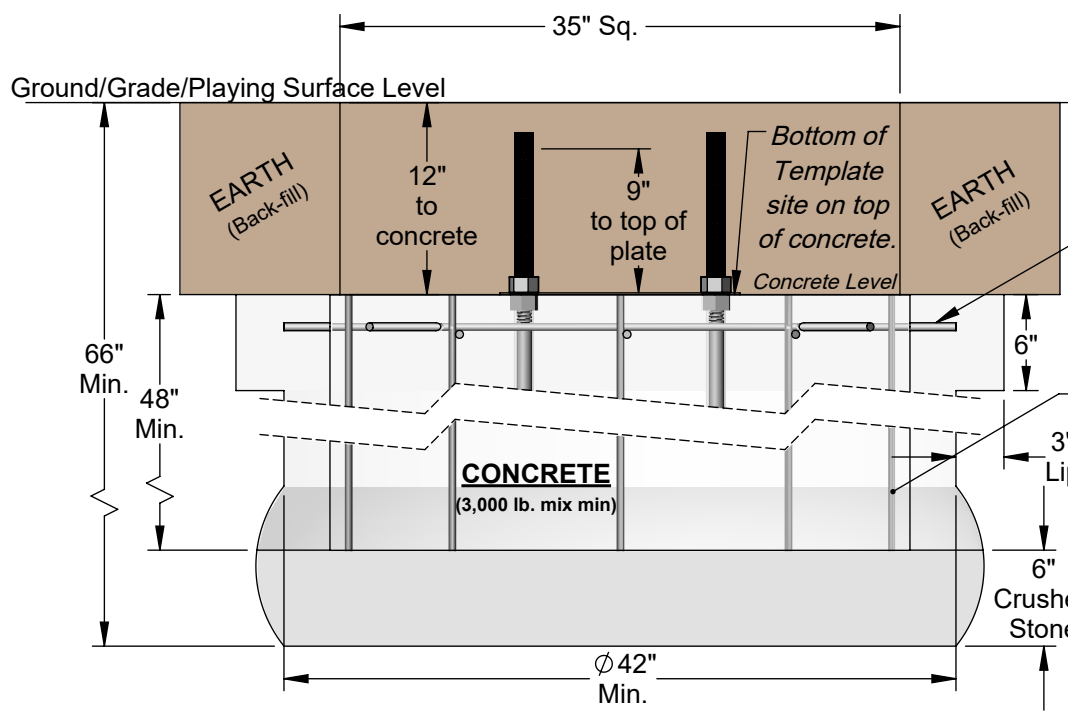

End Line

#3 Tie @ 12" o.c. or Spiral hoop with similar spacing

***NOTE*:**

Make sure to align these critical dimensions correctly between J-bolts!

(12" Vertical/Horizontal Dimensions & 17" Diagonal Dimension)

(10) #5 with Min 3" Cover @ 36° O.C.



Aluminum Athletic Equipment
1000 Enterprise Drive, Royersford, PA 19468
Toll Free: (800) 523-5471 Fax: (610) 825-2378
www.AAEsports.com

DESCRIPTION: ASG-NCAA, 6' Offset Football Goal - Template Installation		
NOTE: Template Installation (with Leveling Nuts)		
MODEL: ASG-NCAA	CATEGORY: CUSTOMER	DATE: 05/18/2021
DWN. BY: CED	CAD FILE: ASG-NCAA, 6' Offset Specifications	DWG. NO. ASG-NCAA-C-002

Consult your local building codes!

6

5

4

3

2

1

A

A

ASG-NCAA - 6' Offset Football Goal

Footing & Weight Specifications

ASG-NCAA
Entire Football Goal
Weighs: 469 lbs./ea.
Total: 938 lbs./pair

(2) Uprights = 37 lbs./ea.

(1) Crossbar = 110 lbs.

(1) Gooseneck = 235 lbs.

(1) Foundation = 50 lbs.

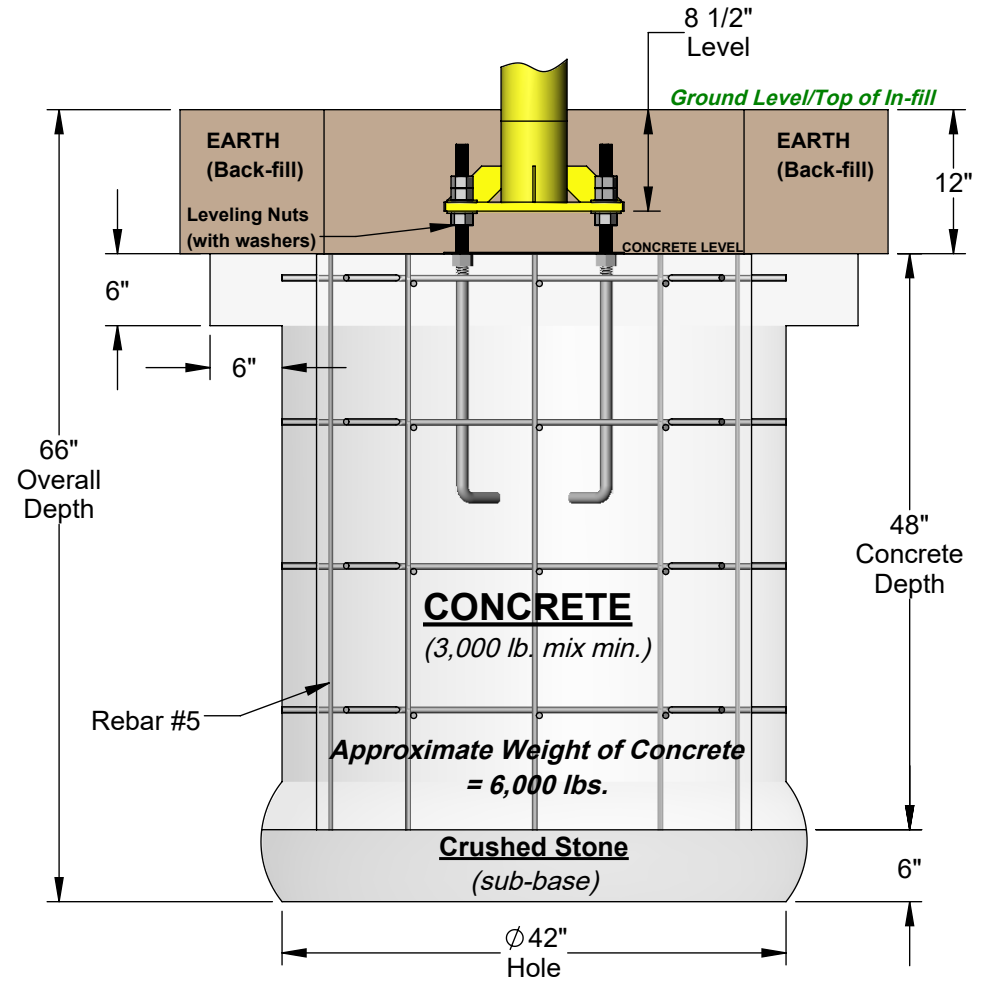
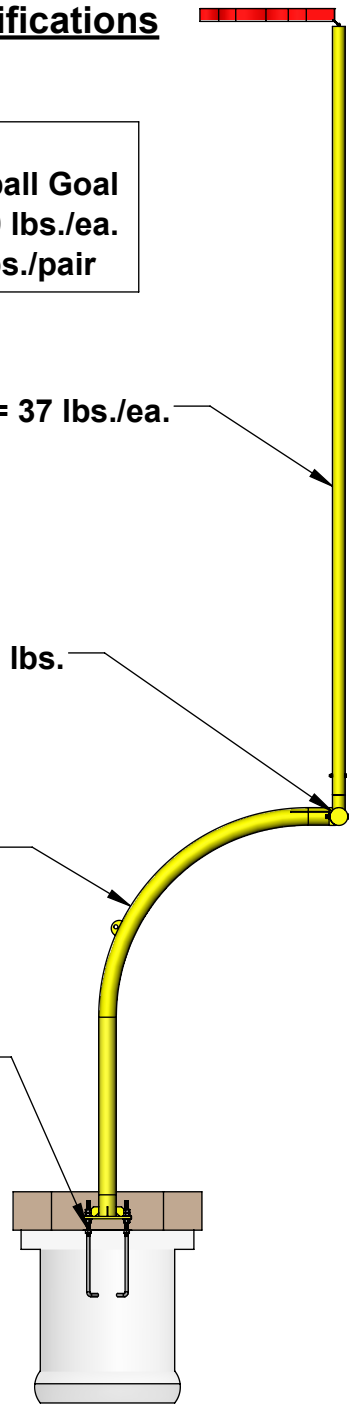

Aluminum Athletic Equipment
 1000 Enterprise Drive, Royersford, PA 19468
 Toll Free: (800) 523-5471 Fax: (610) 825-2378
 www.AAEsports.com

DESCRIPTION:			ASG-NCAA, 6' Offset Football Goal		
NOTE:			Footing and Weight Specifications		
MODEL:	ASG-NCAA	CATEGORY:	CUSTOMER	DATE:	05/18/2021
DWN. BY:	CED	CAD FILE:	ASG-NCAA, 6' Offset Specifications	DWG. NO.:	ASG-NCAA-C-003

ASG-NCAA - Assembly Parts List

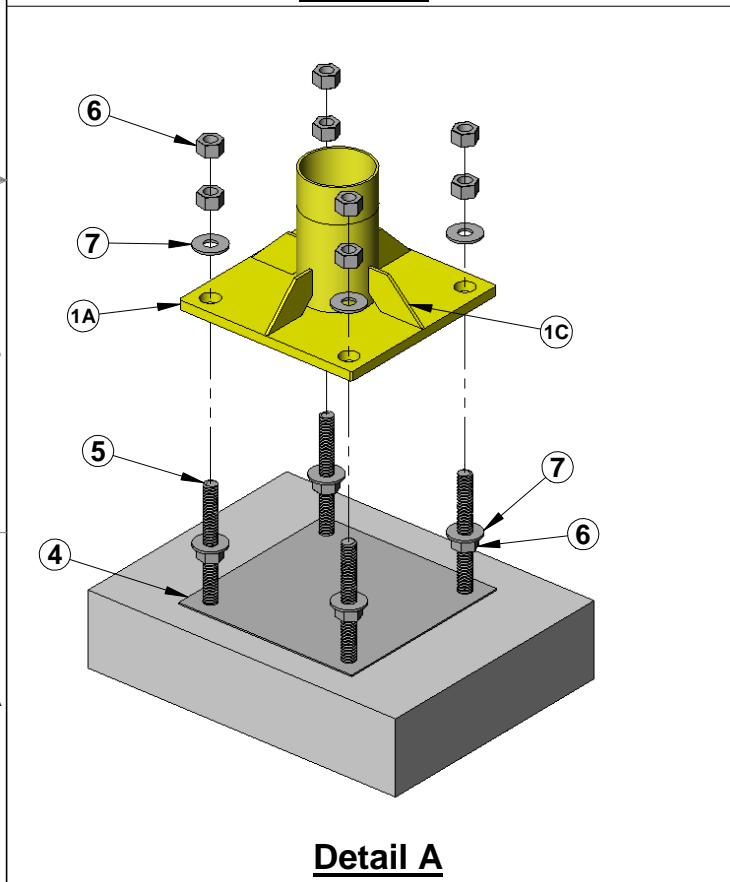
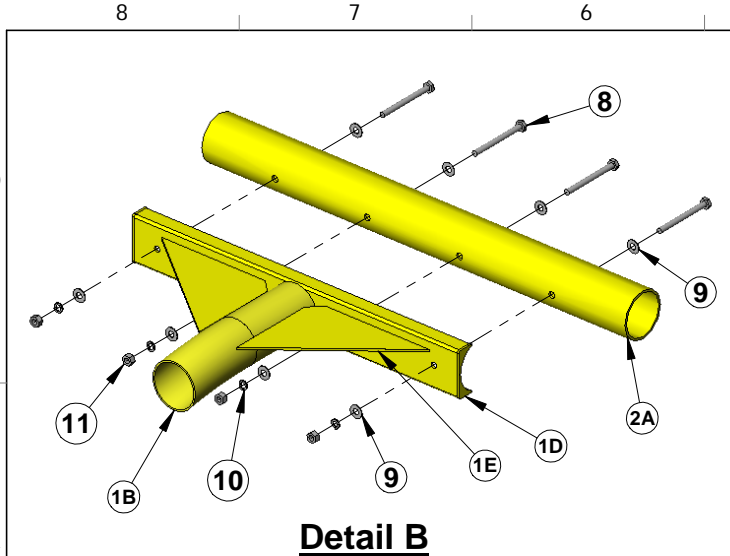
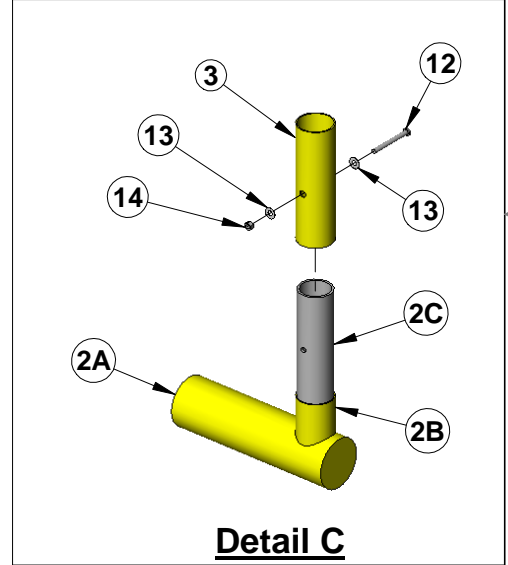
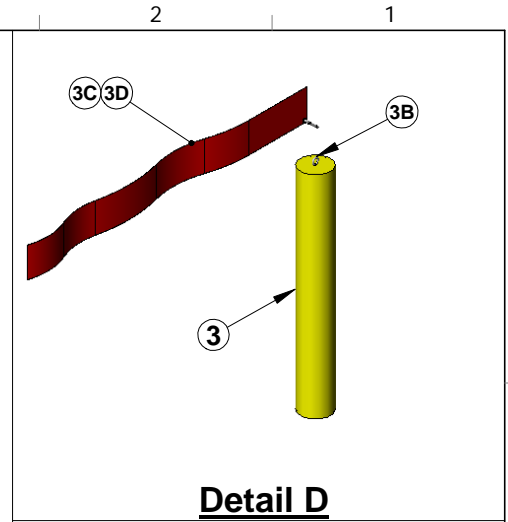
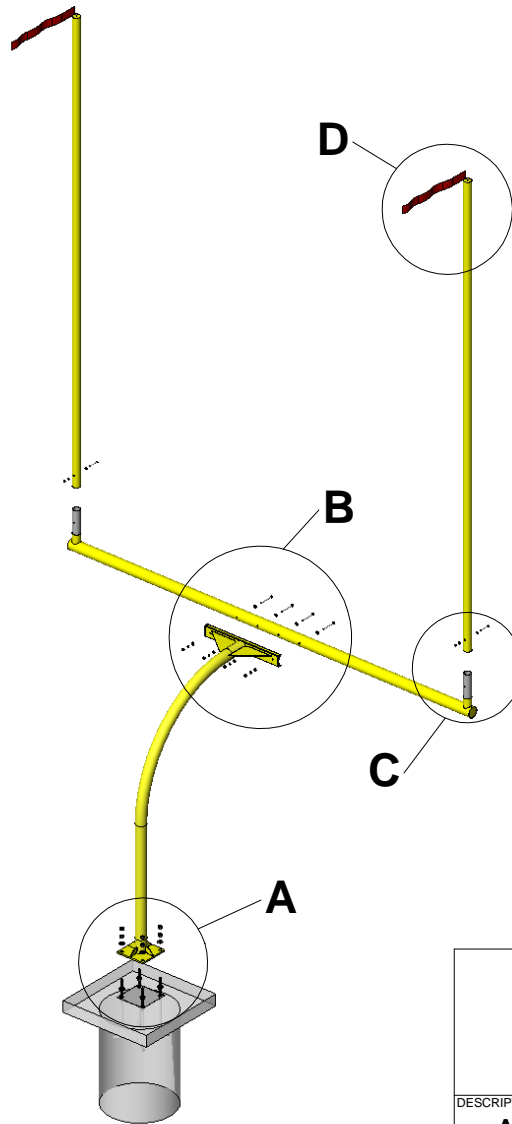

 Aluminum Athletic Equipment 1000 Enterprise Drive, Royersford, PA 19468 Toll Free: (800) 523-5471 Phone: (610) 825-6565 www.aesports.com			
DESCRIPTION:			
ASG-NCAA - 6' Offset - Assembly Parts List			
NOTE:			
Parts List Callout			
MODEL:	ASG-NCAA	CATEGORY:	CUSTOMER
		DATE:	6/1/05
DWN. BY:	TAD	CAD FILE:	ASG-NCAA - Assembly
		DWG. NO.:	ASG-NCAA-6-L-C-004

ASG-NCAA - Template (with J-Bolts) Specifications / Assembly

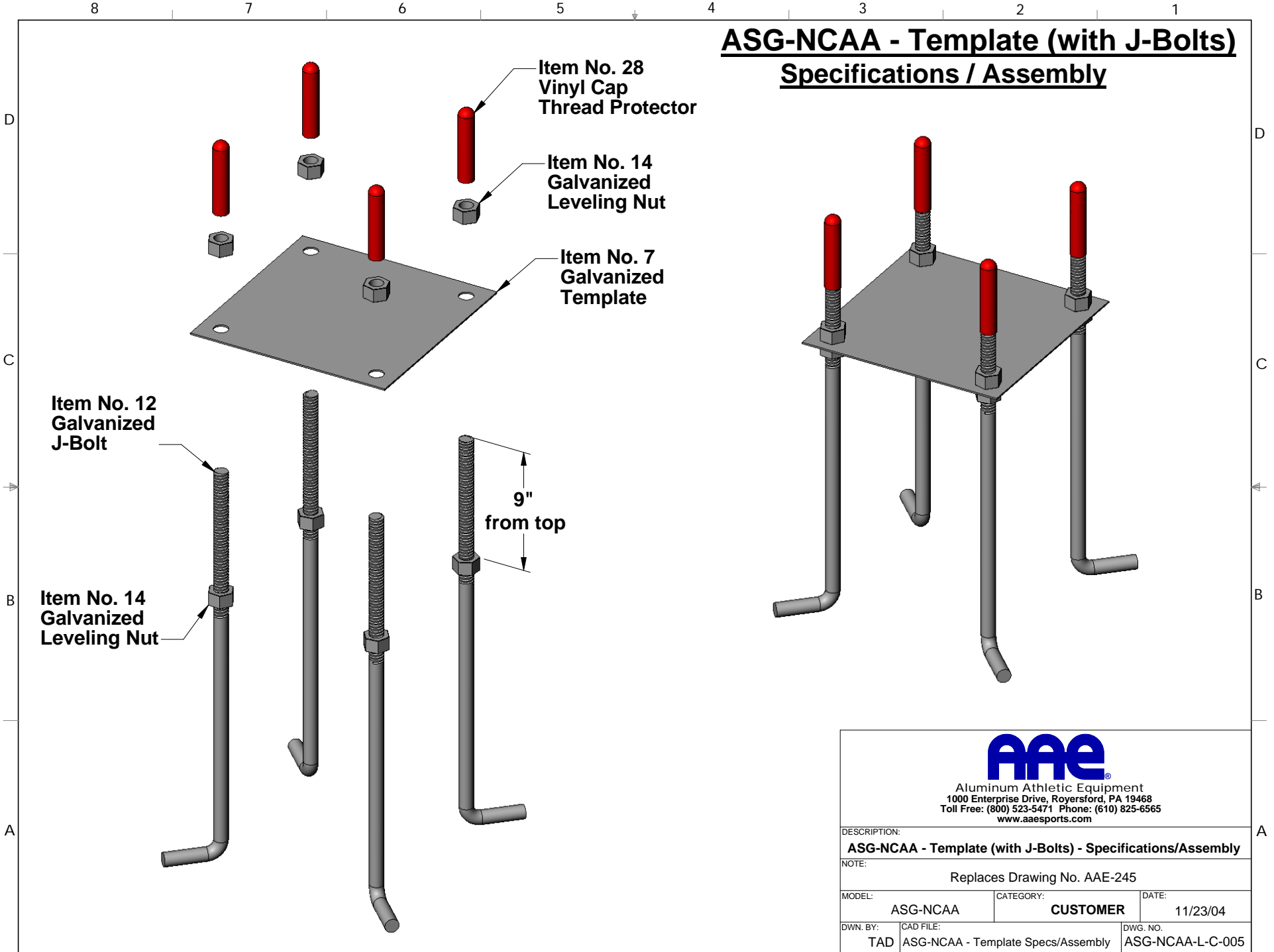

Aluminum Athletic Equipment
1000 Enterprise Drive, Royersford, PA 19468
Toll Free: (800) 523-5471 Phone: (610) 825-6565
www.aaesports.com

DESCRIPTION:		
ASG-NCAA - Template (with J-Bolts) - Specifications/Assembly		
NOTE:		
Replaces Drawing No. AAE-245		
MODEL:	CATEGORY:	DATE:
ASG-NCAA	CUSTOMER	11/23/04
DWN. BY:	CAD FILE:	DWG. NO.:
TAD	ASG-NCAA - Template Specs/Assembly	ASG-NCAA-L-C-005

ASG-HS / ASG-NCAA
6' OFFSET FOOTBALL GOAL
ASSEMBLY & INSTALLATION
(W/ LEVELING NUTS)

TEMPLATE ASSEMBLY: (See Dwg. No. ASG-6-L-C-005)

1. Thread 1"-8 galvanized steel hex nuts (Item no. 7) onto the J-bolts (Item No. 5). Position the first 4 nuts so that the top of each nut is 9" down from the top of the J-bolt.
2. Insert each assembled J-bolt through the holes in the template (Item No. 6) and "tighten" with the remaining 1"-8 hex nuts. Place the vinyl caps (Item No. 5B) over the top of the J-bolts to protect the threads until goal assembly.
3. Once assembled, all the J-bolts should point out from the template (as pictured).

TEMPLATE INSTALLATION: (See Dwg. No. ASG-6-L-C-002)

1. Locate the centerline of the football field and the end zone lines. Make sure that it is the end zone lines that are located and not the goal line.
2. Locate a point 6'-2" back from the front edge of the end line, on the centerline of the football field. (The "front edge" denoting the edge of the 4" painted line closest to the end zone - See Dwg. No. ASG-6-L-C-002 for details)
3. Using this point as the center, dig a hole approximately 42" in diameter, and 5'0" - 6'0" deep. (This is the minimum recommended depth - consult local building codes for concrete depth and drainage requirements.)
4. Add 4" - 6" of crushed stone to the bottom of the hole for proper drainage. (Once again - consult local codes.)
5. Use #5 Rebar or something comparable to help reinforce the concrete installation.

SET THE TEMPLATE ASSEMBLY IN PLACE: (See Dwg. No. ASG-6-L-C-002)

1. Using 2"x4"s, or some other suitable supporting member, suspend the foundation assembly over the excavated hole so that the center of the plate is exactly over the center of the hole (Remember - the center of the hole should be exactly 6'-2" back from the front edge of the end line on the centerline of the football field.) Position the foundation plate assembly so that the top of the foundation plate is exactly 12" below ground level. Use a plumb bob to check that the center of the plate is over the center of the hole.
2. Make sure that the assembly is centered, level and plumb over the hole. The front anchor bolts **MUST** be parallel with the end line. The orientation of these anchor bolts is pertinent to the successful installation of the goal. If these bolts are not parallel to the end line when the concrete is poured, no adjustment can be made later.

ASG-HS / ASG-NCAA
6' OFFSET FOOTBALL GOAL
ASSEMBLY & INSTALLATION
(W/ LEVELING NUTS)

Note: Refer to Drawing No. ASG-6-L-C-002, and make sure that the dimensions between "the J-Bolts" match that to the dimensions given on drawing. (12" Horizontally, 12" Vertically, & 17" Diagonally.)

3. Once all the adjustments have been made, and the foundation assembly is properly supported, the concrete may be poured. If red plastic "stud protectors" (Item No. 5B) are not on the studs already, place them on now to protect the stud while the concrete is being poured. We suggest that a minimum of 3000 lb. concrete mix be used for the foundation.
4. Allow more than ample time (16-18 days) for the concrete to cure before erecting the goal.

ASSEMBLING THE GOAL: (See Dwg. No. ASG-6-L-C-004)

1. Cement should be hardened completely before continuing.
2. All goals are stamped with corresponding numbers and letters. When erecting the goal make sure that all pieces correspond properly.
3. Brush the foundation clean of any dust, debris, etc. Keep the "stud protectors" on the studs.
4. Take the 4 nuts (already on j-bolts) on top of the template and run them up to a distance of 7-1/2" from ground/grade level. Place 1" washers on top of the 4 nuts before goal is assembled.
5. Lay the main standard (gooseneck assembly) (Item No. 1) in front of the concrete foundation. Using at least 4 men, lift and hinge the main standard into place over the foundation plate studs, remove the "stud protectors" and attach using a 1" flat washer, then two 1"-8 hex nuts (Item Nos. 7 & 8). While the goal can still be maneuvered, align it as best as possible. Check the height from ground level to the top of the c-channel (it should be 10') make any adjustments using the leveling nuts. Using a torque wrench, tighten all hex nuts to 75-80 foot-pounds apiece. Nuts may be loosened later if final adjustments need to be made. **NOTE: Never** attempt to tighten down the nuts on the baseplate of the goal without first relieving the pressure of the goal against the nut. Trying to tighten the nut with the weight of the goal pressing on it will damage the threads and cause irreversible damage! (Once entire goal is erected and all final adjustments have been made, cut & place the stud protectors back on the studs.) Thread on second nut using the same foot pounds as the first.
6. Using three (3) men and three (3) ten-foot ladders, (one at each end of the crossbar and one at the middle) raise the crossbar (Item No. 2) into position on the C-Channel (Item No. 1D). Attach crossbar to C-channel using 5/8"-11 x 7" hex

ASG-HS / ASG-NCAA
6' OFFSET FOOTBALL GOAL
ASSEMBLY & INSTALLATION
(W/ LEVELING NUTS)

- bolts, flat washers, lock washers, and hex nuts (Item Nos. 9,10,11, & 12). One (1) flat washer should be installed on the front side of the crossbar, with a flat washer, lock washer and hex nut on the rear. Install all crossbar bolts and hardware. Using a torque wrench, tighten all 6 bolts to 70 foot-pounds apiece.
7. If red streamers (Item No. 3C & 3D) are not attached to the top of the 4" uprights, do so at this time with the enclosed hardware. Eyebolts are provided at the top of each upright for attachment.
 8. Move two (2) ladders to one end of the crossbar. Using two people, lift the upright (Item No. 3) into position on the crossbar. Attach upright through aluminum sleeve (item No. 2C) using 1/2"-13 x 5" hex bolts, flat washers, and hex nuts (Item Nos. 13,14, & 15). Attach hardware so that the heads of the bolts are on the front of the upright and on the inside of the upright. Torque bolts to 60 foot pounds a piece.
 9. Repeat Step No. 8 for other upright.
 10. Make any necessary adjustments to make the goal plumb, and square with the end line. The top of the crossbar should be 10'-0" from ground level. Any additional adjustments should be made, such as the uprights leaning forward can be fixed by loosening the 4 crossbar bolt assemblies, and using three (3) men and three (3) 10' ladders (one at each upright and one in the center of the crossbar), pull back on uprights until perpendicular (use a 4' level). Once they are perpendicular have the person on the center ladder re-torque the 4 bolts attaching the crossbar to the c-channel. (Once entire goal is erected and all final adjustments have been made, cut & place the vinyl protector caps back on the J-bolts.)
 11. Repeat Steps 1-10 to assemble other goal.

ASG-HS / ASG-NCAA
6' OFFSET FOOTBALL GOAL
ASSEMBLY & INSTALLATION
(W/ LEVELING NUTS)

OPERATION AND CARE:

1. If the goal is to be removed, AAE's synthetic foundation box and covers (FBC-S-ASG) should be used. "Stud protectors" should be placed on the studs whenever possible. If the stainless hardware is removed, anti-seize compound should be applied to the hardware prior to re-installation.
2. All bolts and nuts should be checked and re-torqued each year. It is important the aforementioned torque specifications be followed as over-torquing will snap or destroy bolts or studs. Failure to properly maintain the goal on a regular basis, as with any other large equipment, could lead to serious injury or death.
3. Never attempt to tighten down the nuts on the baseplate of the goal without first relieving the pressure of the goal against the nut. Trying to tighten the nut with the weight of the goal pressing on it will damage the threads and cause irreversible damage!
4. **ALWAYS** wear protective gloves and hardhat when assembling goals!

**ASG-NCAA
SINGLE 6' OFFSET
NCAA FOOTBALL GOALS
PARTS LIST**

Part#	Item	Description	Qty.
1	Gooseneck Assembly	Gooseneck assembly is completely galvanized after the following components are welded then powder-coated white or yellow:	2
1A	Baseplate	15" sq. x 3/4" thick, HRS	***
1B	Gooseneck	5-1/2" o.d. x .188" wall steel tubing	***
1C	Baseplate Rib	4-1/2" x 3" x 1/4" thick HRS	***
1D	C-Channel	5-9/16" x 2-1/8" legs x 1/4" wall, 42" lg., HRS	***
1E	C-Channel Rib	12" x 15" x 1/4" steel reinforcing plate, HRS, w/ welded end cap	***
2	Crossbar Assembly	Crossbar assembly is completely welded then powder-coated white or yellow:	2
2A	Crossbar	5" Sch. 40 aluminum pipe, 5-9/16" o.d. x .258 wall x 19'-4" lg., 6061T6	***
2B	Outer Sleeve	4" dia. x .125" wall, 6061T6 aluminum tube	***
2C	Sleeve Insert	3-3/4" dia. x .375" wall, 6061T6 aluminum tube	***
3	Upright Assembly	Uprights have a cap at the top welded then powder-coated white or yellow:	4
3A	Upright	4" o.d. x .125 wall x 20' lg., 6061T6 aluminum tube	***
3B	Eyebolt	5/16" eyebolt, stainless steel	***
3C	Streamer	4" x 42" red nylon streamer	***
3D	Clip	Aluminum pear clip	***
4	Foundation Template	15" sq. x 11 gauge HRS, galvanized	2
5	J-Bolt	1"-8 x 33" lg. j-bolt, grade 5, galvanized steel	8
5B	Vinyl Cap	1" dia. x 8" lg. red vinyl cap protector	8
6	Nut	1"-8 nut, grade 5, galvanized steel	32

**ASG-NCAA
SINGLE 6' OFFSET
NCAA FOOTBALL GOALS
PARTS LIST**

7	Washer	1" doc washer, grade 5, galvanized steel	16
8	Bolt	5/8"-11 x 7" bolt, galvanized steel	8
9	Washer	5/8" washer, galvanized steel	16
10	Loc-washer	5/8" loc-washer, galvanized steel	8
11	Nut	5/8"-11 nut, galvanized steel	8
12	Bolt	1/2"-13 x 5" bolt, galvanized steel	4
13	Washer	1/2" washer, galvanized steel	8
14	Nut	1/2"-13 nut, galvanized steel	4

*** Items are included in the assembled part.

FOR TECHNICAL ASSISTANCE, CALL 1-800-523-5471