

CHDC

NCAA Hammer-Discus Cage

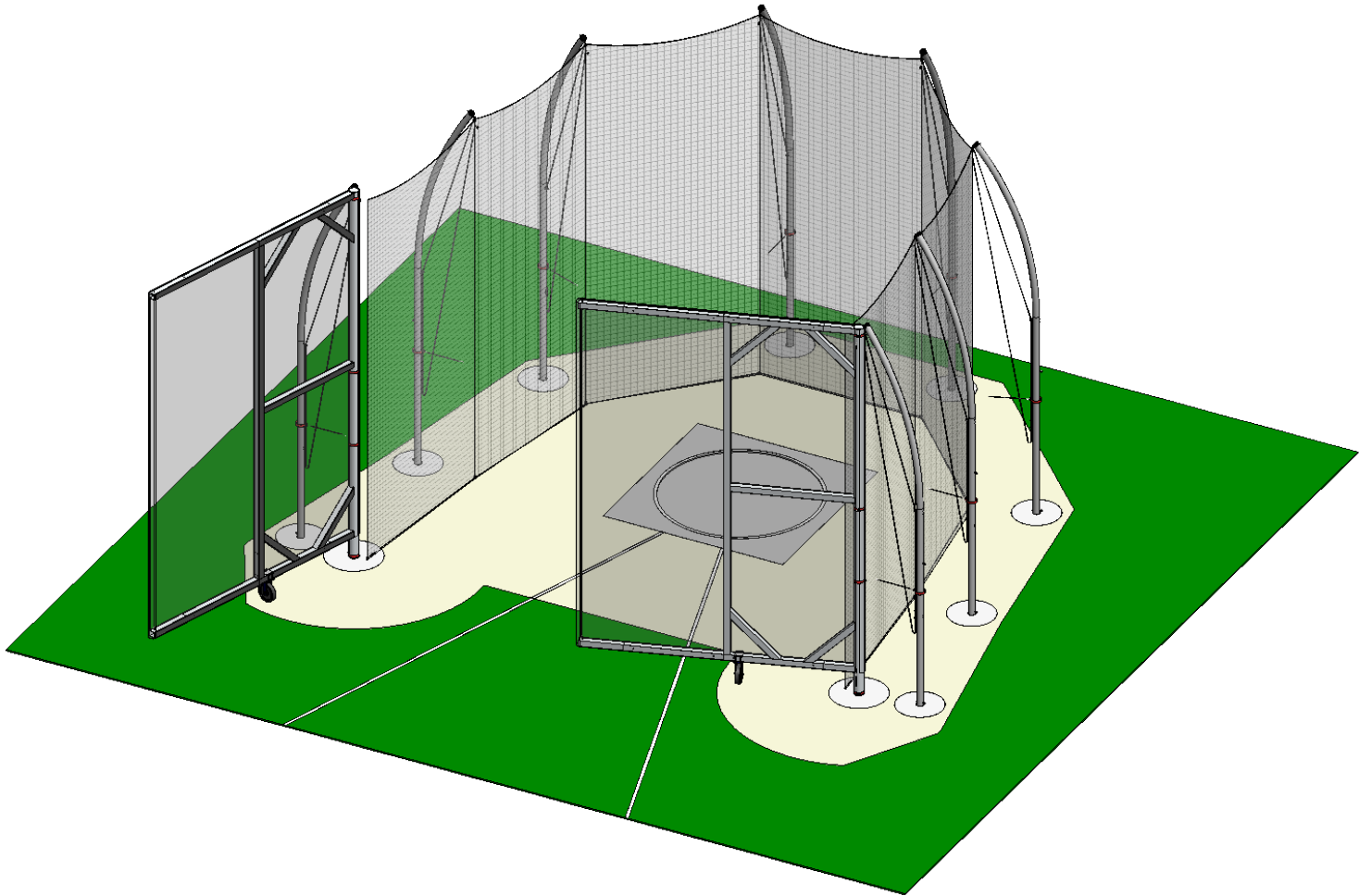

Aluminum Athletic Equipment
1000 Enterprise Drive, Royersford, PA 19468
Toll Free: (800) 523-5471 Fax: (610) 825-2378
www.AAEsports.com

6

5

4

3

2

1

CHDC NCAA Hammer-Discus Cage Ground Sleeve Placements

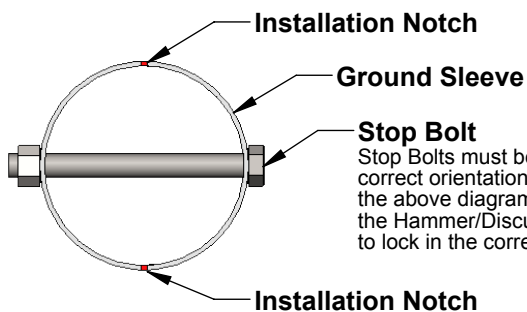
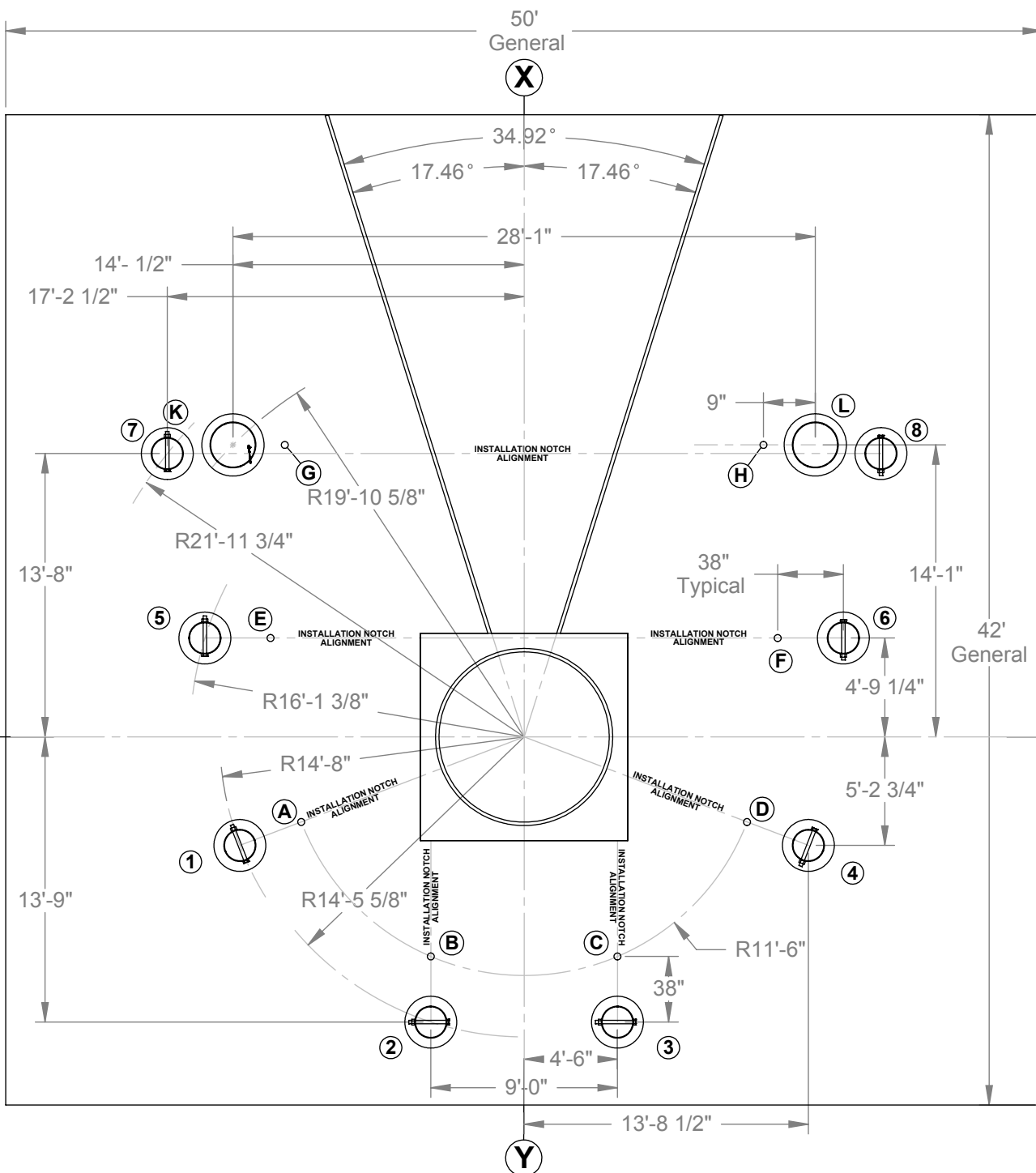

Stop Bolt
Stop Bolts must be in the correct orientation as shown in the above diagram in order for the Hammer/Discus Cage posts to lock in the correct position!



Aluminum Athletic Equipment
1000 Enterprise Drive, Royersford, PA 19468
Toll Free: (800) 523-5471 Fax: (610) 825-2378
www.AAEsports.com

| | | |
|---|--------------------------|------------------------|
| DESCRIPTION: CHDC - NCAA Hammer-Discus Cage | | |
| NOTE: Ground Sleeve Placements | | |
| MODEL: CHDC | CATEGORY: CUSTOMER | DATE: 08/05/11 |
| DWN. BY: ARP | CAD FILE: CHDC Packet | DWG. NO. CHDC-C-001 |

4

3

2

1

CHDC NCAA Hammer-Discus Cage Plan View Layout

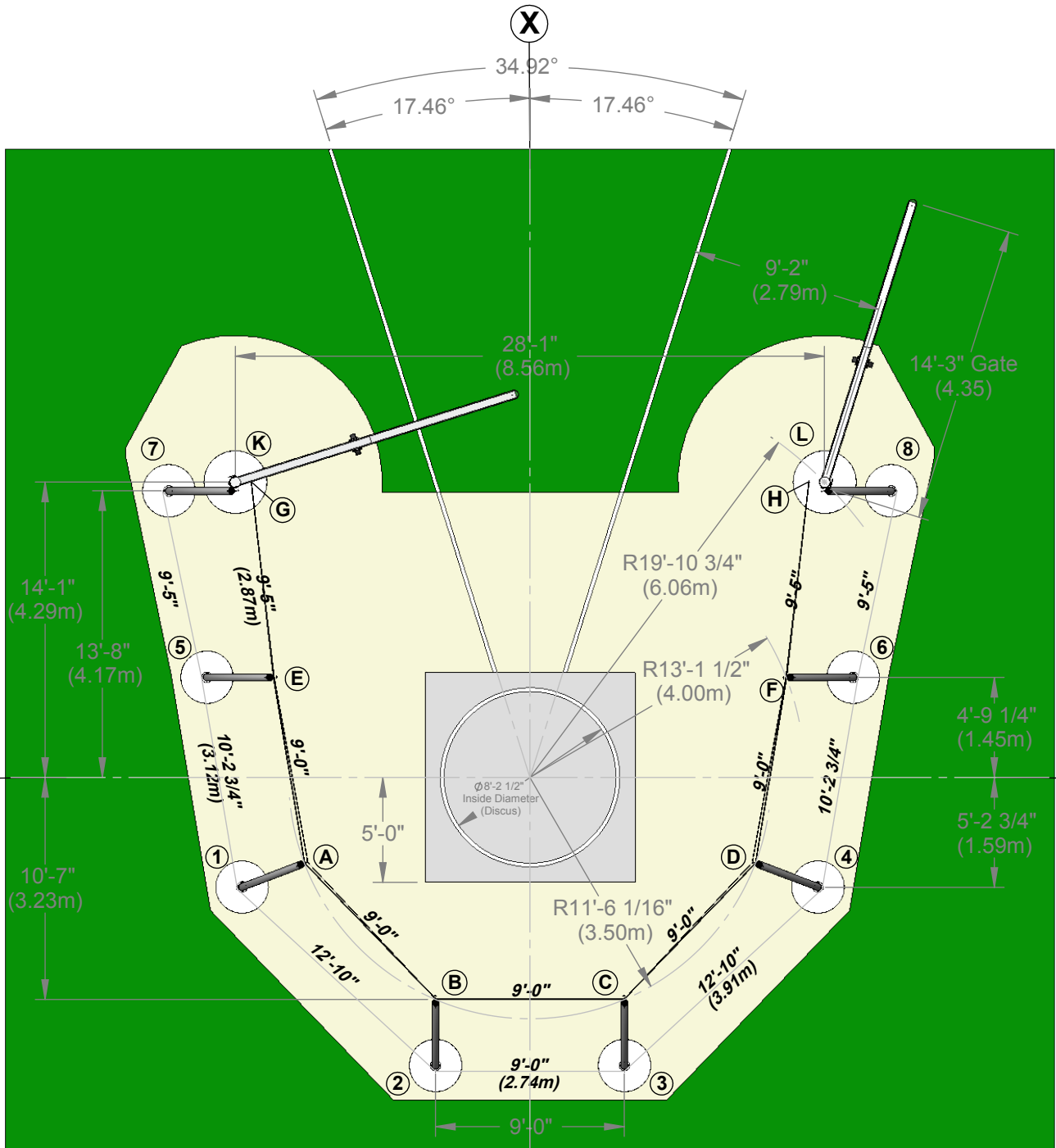

A AE recommends that a 6" - 8" thick concrete pad be poured for the entire throwing area (as shown).
Important: concrete must cover an 8' radius from the gate posts (K & L) to create a level surface for the gate wheel.

Meets & Exceeds All NCAA Rules & Specifications

Main Net Size = 20'-0" High x 65'-0" Perimeter
 Optional Barrier Net Size = 8'-0" High x 74'-0" Perimeter



Aluminum Athletic Equipment
 1000 Enterprise Drive, Royersford, PA 19468
 Toll Free: (800) 523-5471 Fax: (610) 825-2378
www.AAEsports.com

| | | |
|--|------------------------------|------------------------|
| DESCRIPTION: CHDC - Plan View Layout | | |
| NOTE: NCAA Hammer-Discus Cage | | |
| MODEL: CHDC | CATEGORY: CUSTOMER | DATE: 08/05/11 |
| DWN. BY: ARP | CAD FILE: CHDC Packet | DWG. NO. CHDC-C-002 |

CHDC NCAA Hammer-Discus Cage Ground Cable Specifications

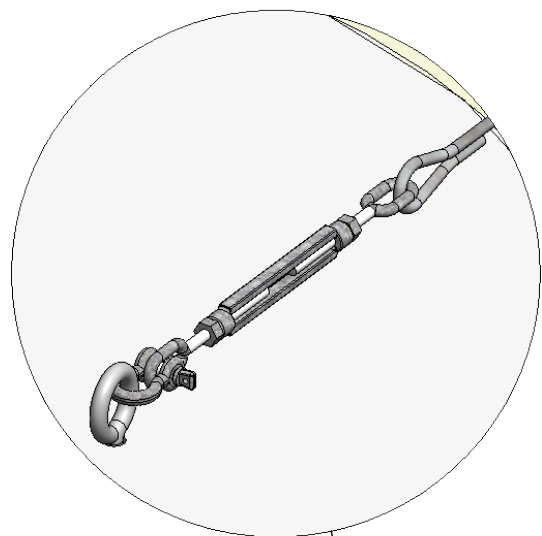

DETAIL A

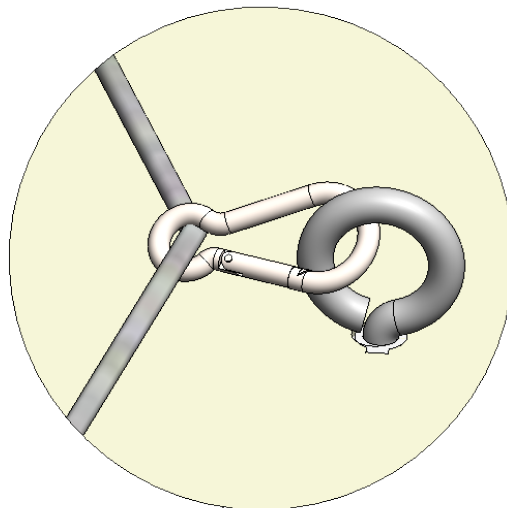

DETAIL B

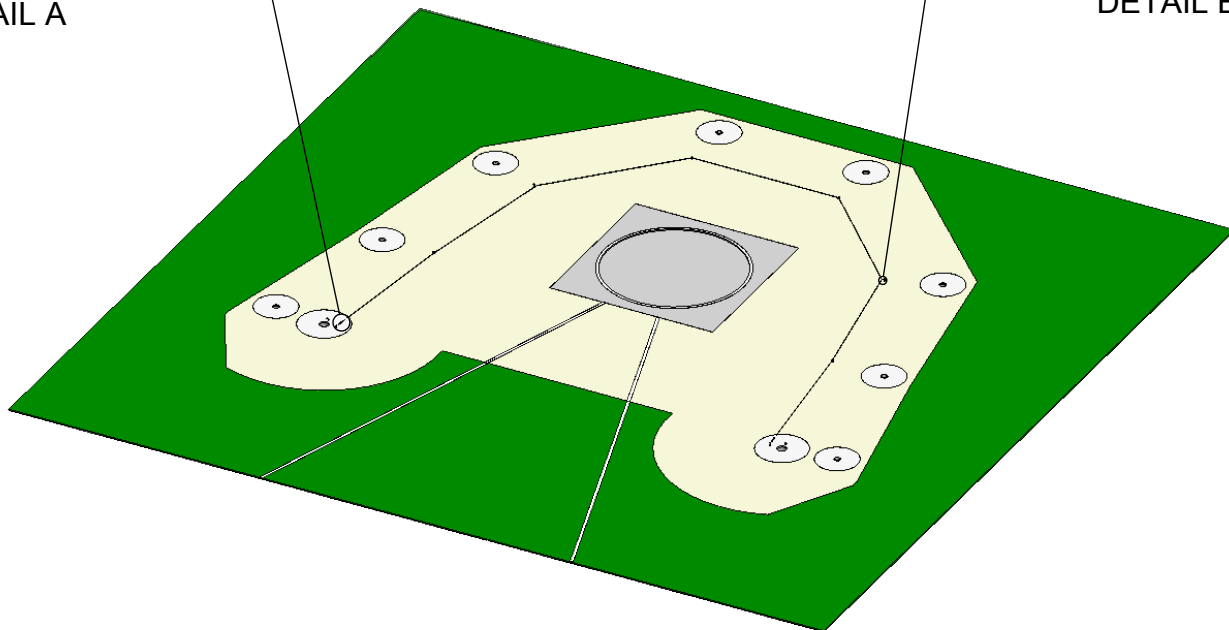

Notes:

- \varnothing 1/4" x 61'-6" long vinyl-coated galvanized steel cable with a galvanized thimble, galvanized turnbuckle, and galvanized anchor shackle at each end (total of 2 of each)
- Anchor shackles attach the cable to eyebolts at the mouth of the cage (Detail A)
- Stainless steel pear clips attach the cable to eyebolts around the perimeter of the cage net (Detail B)
- Plastic wire ties secure the bottom of the net to the ground cable about every 18"



Aluminum Athletic Equipment
1000 Enterprise Drive, Royersford, PA 19468
Toll Free: (800) 523-5471 Fax: (610) 825-2378
www.AAEsports.com

| | | | |
|---|--------------------------|------------------------|--|
| AAE | | | |
| Aluminum Athletic Equipment 1000 Enterprise Drive, Royersford, PA 19468 Toll Free: (800) 523-5471 Fax: (610) 825-2378 www.AAEsports.com | | | |
| DESCRIPTION: CHDC - Ground Cable Specifications | | | |
| NOTE: NCAA Hammer-Discus Cage | | | |
| MODEL: CHDC | CATEGORY: CUSTOMER | DATE: 01/12/12 | |
| DWN. BY: ARP | CAD FILE: CHDC Packet | DWG. NO. CHDC-C-003 | |

CHDC NCAA Hammer-Discus Cage Gate Specifications

Main cage netting attaches to gate using pear clips snapped to the Gate Cable Assembly every 18" to hold the net as close to the gate as possible.

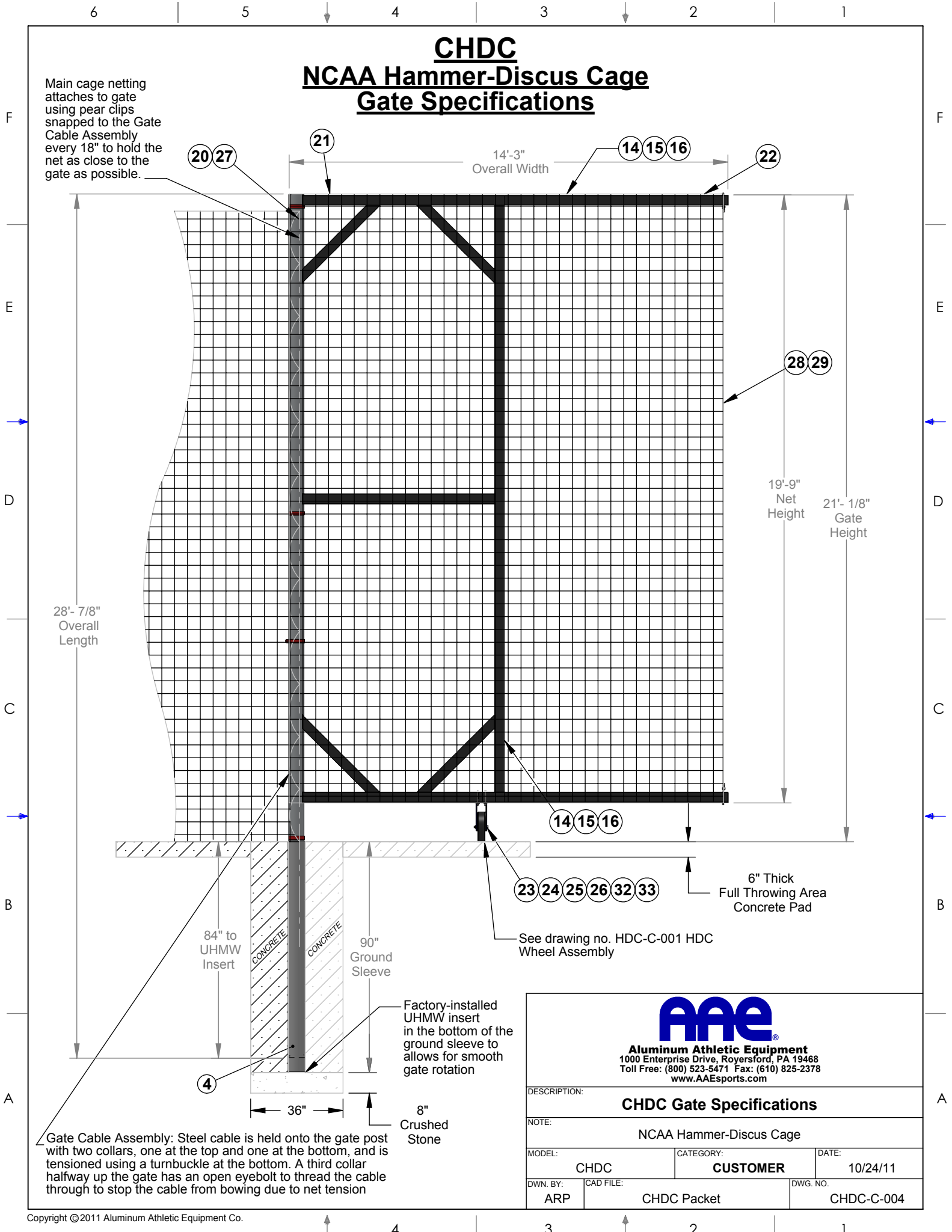

28'- 7/8"
Overall Length

14'-3"
Overall Width

19'-9"
Net Height

21'- 1/8"
Gate Height

84" to
UHMW
Insert

90"
Ground
Sleeve

Factory-installed
UHMW insert
in the bottom of the
ground sleeve to
allows for smooth
gate rotation

8"
Crushed
Stone

6" Thick
Full Throwing Area
Concrete Pad

See drawing no. HDC-C-001 HDC
Wheel Assembly

Gate Cable Assembly: Steel cable is held onto the gate post with two collars, one at the top and one at the bottom, and is tensioned using a turnbuckle at the bottom. A third collar halfway up the gate has an open eyebolt to thread the cable through to stop the cable from bowing due to net tension



Aluminum Athletic Equipment
1000 Enterprise Drive, Royersford, PA 19468
Toll Free: (800) 523-5471 Fax: (610) 825-2378
www.AAEsports.com

| | | | |
|---|--------------------------|------------------------|--|
| DESCRIPTION: CHDC Gate Specifications | | | |
| NOTE: NCAA Hammer-Discus Cage | | | |
| MODEL: CHDC | CATEGORY: CUSTOMER | DATE: 10/24/11 | |
| DWN. BY: ARP | CAD FILE: CHDC Packet | DWG. NO. CHDC-C-004 | |

CHDC NCAA Hammer-Discus Cage Installation/Upright Specifications

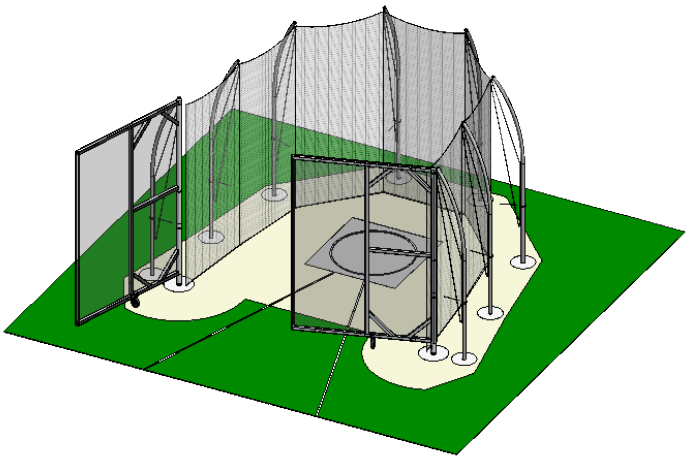
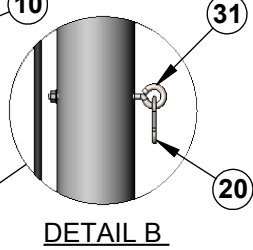
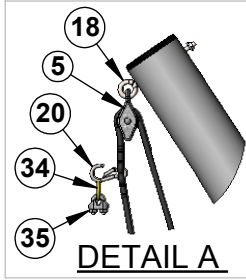
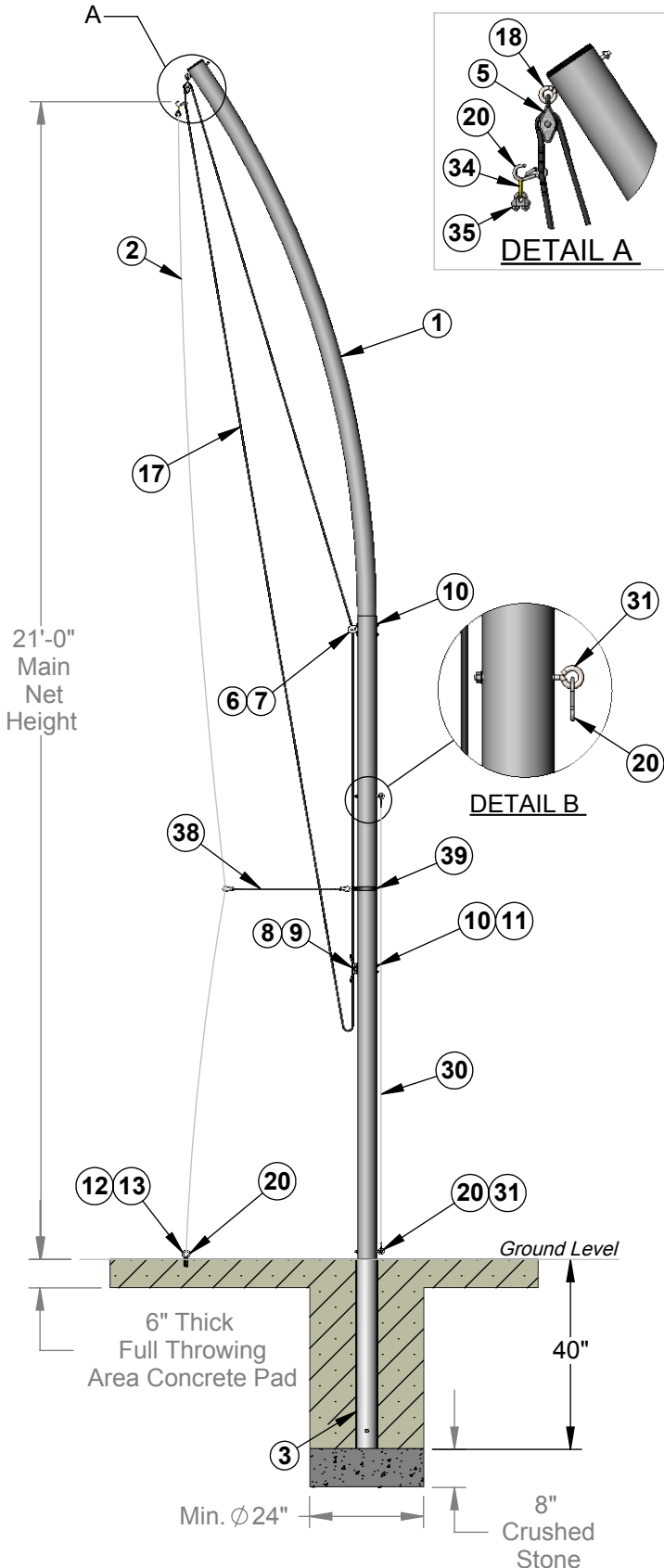

CHDC Ground Sleeve

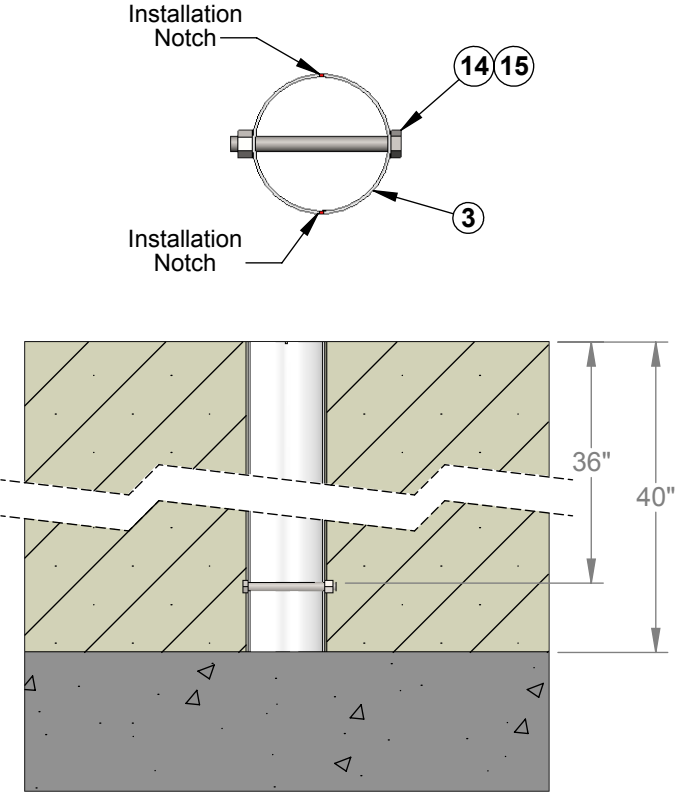

Consult Local Codes



Aluminum Athletic Equipment
1000 Enterprise Drive, Royersford, PA 19468
Toll Free: (800) 523-5471 Fax: (610) 825-2378
www.AAEsports.com

| | | |
|---|-------------|------------|
| DESCRIPTION: | | |
| CHDC - Installation/Upright Specifications | | |
| NOTE: | | |
| NCAA Hammer-Discus Cage | | |
| MODEL: | CATEGORY: | DATE: |
| CHDC | CUSTOMER | 08/05/11 |
| DWN. BY: | CAD FILE: | DWG. NO.: |
| ARP | CHDC Packet | CHDC-C-005 |

**CHDC
NCAA HAMMER-DISCUS CAGE
PARTS LIST**

| Pt# | Item | Description | Qty. |
|-----|-----------------------------------|--|-------------|
| 1 | Upright | 4.00" O.D. x .226 x 24'0" aluminum tube, 36" arc offset, 6061T6 | 8 |
| 2 | Main Net | #820H - 20' x 65', framed with 3/8" rope, B-treated, 1 3/4" square w/ integrated anti-sag cable | 1 |
| 3 | Upright Ground Sleeve | 4.35" O.D. x .100" x 40" aluminum tube, 6061T6 with factory-installed stop bolt | 8 |
| 4 | Gate Ground Sleeve | 6.625" O.D. x .134" x 90" aluminum tube, 6061T6 with factory-installed UHMW insert | 2 |
| 5 | Hanging Swivel Pulley | #3-5 fast eye, galvanized steel, swivel pulley | 8 |
| 6 | Fixed Pulley | #1 deck block galvanized steel pulley | 8 |
| 7 | Pulley Bolt | 1/4"-20 x 4 1/2" hex bolt, S.S. | 16 |
| 8 | Cleat | 6" galvanized steel cleat | 8 |
| 9 | Cleat Bolt | 1/4"-20 x 5 1/2" hex bolt, S.S. | 16 |
| 10 | Hex Nut | 1/4"-20 steel nylon lock nut, S.S. | 32 |
| 11 | Acorn Nut | 1/4"-20 steel acorn nut, S.S. | 16 |
| 12 | Eyebolt | 3/8"-16 x 2 1/2" eyebolt, S.S. | 8 |
| 13 | Concrete Anchor | 3/8"-16 tampin insert, P25T | 8 |
| 14 | Hex Bolt | 1/2"-13 x 5" steel hex bolt, S.S. | 36 |
| 15 | Hex Nut | 1/2"-13 steel hex nylon lock nuts, 18-8 S.S. | 36 |
| 16 | Washer | 1/2" flat washer, S.S. | 28 |
| 17 | Hoisting Rope | 5/16" polypropylene black braided rope w/ pear clip, 32' long | 8 |
| 18 | Eyebolt | 5/16"-18 x 6" steel eyebolt, S.S. | 8 |
| 19 | Hex Nut | 5/16"-18 steel hex nylon lock nuts, 18-8 S.S. | 8 |
| 20 | Pear Clip | Spring hook clip, 1/4" dia. (*2 extra per upright with optional barrier net) | 24 (*40) |
| 21 | Main Gate Frame | Rotating Gate main frame (7'-0" x 19'-9" with 6" x 24'-0" post) | 2 |
| 22 | Gate Extension Arm | 4" sq. x .250" wall x 7'-3" 6061T6 aluminum welded frame with 1/2" thick pre-drilled welded plate | 4 |
| 23 | Fixed Caster | 12" fixed caster, 15" high | 2 |
| 24 | Caster Bolt | 3/8"-16 x 5" steel hex bolt, S.S. | 8 |
| 25 | Hex Nuts | 3/8"-16 steel hex nylon lock nuts, 18-8 S.S. | 8 |
| 26 | Washer | 3/8" lock washer, S.S. | 8 |
| 27 | Vertical Gate Post Cable Assembly | Assembly comprised of: 1 ea. 21'-6" lg. 1/4" galvanized cable 2 ea. 1/4" galvanized thimbles 1 ea. Galvanized turnbuckle 3 ea. Galvanized post collars vinyl-coated black 2 ea. 3/8" -16 x 2 1/2" forged closed eyebolts 1 ea. 3/8" -16 x 2 1/2" forged open eyebolt | 2 |

**CHDC
NCAA HAMMER-DISCUS CAGE
PARTS LIST**

| Pt# | Item | Description | Qty. |
|-----|-------------------------------------|--|------|
| 28 | Gate Extension Cable Assembly | 6 ea. 3/8" -16 nylon lock nuts, S.S. Assembly comprised of: 1 ea. 20'-6-1/2" lg. 1/4" galvanized cable 2 ea. 1/4" galvanized thimbles 1 ea. Galvanized turnbuckle 2 ea. 3/8"-16 x 6" forged eyebolts 2 ea. 3/8" flat washers, S.S. 2 ea. 3/8" nylon lock nuts, S.S. | 2 |
| 29 | Gate Net | N820H - 20' high, 29' around, 1 end open, framed, B-treated | 2 |
| *30 | Barrier Net | N820H- 8'x 74' framed with 3/8" rope, B-treated | 1 |
| *31 | Eyebolt (Barrier Net) | 5/16" – 18 x 2-1/4" eyebolt, S.S. (optional) | 16 |
| 32 | Caster Plate | 6 1/4" x 4 3/4" x 1/8" pre-drilled attachment plate | 2 |
| 33 | Caster Shims | 4" x 5" aluminum shims to ensure constant contact between the gate wheel and the concrete pad; eight 1/4" thick, two 1/8" thick | 6 |
| 34 | O-Ring | 1" I.D. brass O-ring | 8 |
| 35 | Cable Clamp | Galvanized steel cable clamp assembly | 8 |
| 36 | Ground Cable Assembly | Assembly Comprised of: 1 ea. 63'-0" lg. 1/4" vinyl-coated galvanized cable 2 ea. 1/4" galvanized thimble 2 ea. Galvanized turnbuckle 2 ea. Galvanized anchor shackle | 1 |
| 37 | Horizontal Pull- Back Cable | 63'-0" lg. 1/4" vinyl-coated galvanized cable looped with galvanized thimbles at both ends | 1 |
| 38 | Net Retractor | 5/16" polypropylene black braided rope w/ pear clip on each end, 24" long | 6 |
| 39 | Galvanized Post Collar | 6" I.D. galvanized steel collar vinyl-coated black w/ 3/8" stainless steel hardware | 16 |

*** OPTIONAL ITEMS FOR BARRIER NET**

FOR TECHNICAL ASSISTANCE, CALL 1-800-523-5471

K:\AAE Data\PDF Files\Z-Product Instructions & Parts Lists\Track & Field\CHDC\CHDC Parts List.doc
Copyright © 2011 Aluminum Athletic Equipment Co.

**CHDC
NCAA HAMMER-DISCUS CAGE
LAYOUT AND INSTALLATION INSTRUCTIONS**

LAYOUT - (Refer to Drawing No. CHDC-C-001 & 002 for details)

Step No. 1 Using masonry string, establish perpendicular lines "MN" and "XY", which intersect at point "O", the center of the hammer circle.

Step No. 2 Refer to drawing no. CHDC -C-001 to locate points "1" thru "8".

NOTE: Points "1" thru "8" are the location of the center of the ground sleeves (for the main uprights) to be installed.

Step No. 3 Refer to drawing no. CHDC-C-001 to locate points "A" thru "H".

NOTE: Points "A" thru "H" are the location of the eyebolts that will anchor the Ground Cable Assembly.

Step No. 4 Refer to drawing CHDC -C-001 to locate points "K" and "L".

NOTE: Points "K" and "L" are the location of the center of the rotating gate ground sleeves to be installed.

INSTALLATION

Step No. 1
Full Throwing Area
Concrete Pad
Excavation

Dig an area for the 6"-8" thick Full Throwing Area Concrete Pad (minimum recommended coverage shown in drawing no. CHDC-C-002). The pad must include an area with a radius of at least 8' from the gate posts (K & L) to create a level area for the gate wheel to roll. **Consult local building codes for depth and drainage requirements.**

**See Drawing No.
CHDC-C-002**

NOTE: AAE recommends that a concrete pad be installed for the entire throwing area to reduce maintenance around the net. This eliminates the need to cut grass around the net, reducing the risk of cutting the net with maintenance equipment. This also reduces the risk of debris collecting in the ground sleeves and concrete anchors. AAE also recommends a dedicated warm-up area of concrete or artificial turf to prevent mud, grass, etc. from being tracked into the throwing area. This is not only aesthetically beneficial, but keeping the throwing area free of debris of any kind is essential for the throwers' safety.

Step No. 2
Placing Ground
Sleeves

Drill or dig 24"-30" diameter holes a minimum of 48" deep (**Consult local building codes for concrete depth and drainage requirements.**) at points "1" thru "8" and minimum 36" diameter and 98" deep at points "K" and "L" (Gate Sleeves). Fill the bottom of each hole with approximately 8" of crushed stone, so the depth from ground level to the top of the stone is 40" for holes "1" thru "8" and 90" for holes "K" and "L". Insert the upright ground sleeves (Item No. 3) at points "1" thru "8" ("bolt side" down). Make sure the ground sleeves are flush with the ground, centered, leveled, (individually, as well as with each other), and plumb. Also, rotate the ground sleeves so that

**See Drawing No.
CHDC-C-001 &
002 for Steps 2-5**

CHDC
NCAA HAMMER-DISCUS CAGE
LAYOUT AND INSTALLATION INSTRUCTIONS

the two (2) grooves (Installation notches) on top of the ground sleeve are aligned correctly - See drawing no. CHDC-C-001 for details. A masons string or straight edge may be used to aid in the aligning process.

NOTE: All listed depths are measured from the desired ground level at completion.

NOTE: It is **extremely important** that the installation notches on top of the ground sleeve are in proper alignment, so the key slot in the main upright will lock the upright into its proper position when set into the ground sleeve.

Step No. 3
Placing Gate
Ground Sleeves

Install the gate ground sleeves (Item No. 4) "UHMW side" down at points "K" and "L". Make sure the ground sleeves are flush with the ground, centered, and plumb. Be sure the inside depth of the ground sleeve to the UHMW insert is 84". The rotating gate ground sleeves have no installation notches, and thus require no special positioning.

Step No. 4
Pouring Full
Throwing Area
Concrete Pad

When all the ground sleeves are in the proper position and alignment, the concrete can be poured for the entire throwing area. **(Be sure not to get any concrete inside the ground sleeves!)** As the concrete cures, constantly check to see that the ground sleeves are flush with the ground, centered, plumb, and in the correct alignment. Add expansion joints to the pad as necessary.

Step No. 5
Drilling and
Installing Concrete
Anchors

Drill 3/4" diameter holes 1 3/4" deep at points "A" thru "H". Use a hammer to tap a concrete anchor (Item No. 13), "thread-side" down, into each of the holes. Allow a small amount of the anchor to protrude from the hole (about 1/4" or less) for maximum expansion. Thread 3/8"-16 eyebolts (Item No. 12) into the anchors until tight.

Step No. 6
Ground Cable
Assembly
Installation

See Drawing No.
CHDC-C-003

Lay out the Ground Cable Assembly (Item No. 36) around the perimeter of the cage (marked by eyebolts at points "A" thru "H"). Attach the anchor shackle at each end of the Ground Cable Assembly to the eyebolts at point "G" and "H" (See Detail A in drawing no. CHDC-C-003). Use pear clips (Item No. 20) to secure the cable to each of the other six (6) eyebolts at points "A" thru "F" (See Detail B in drawing no. CHDC-C-003). Tension the cable using the turnbuckles at both ends.

Step No. 7
Upright Assembly

See Drawing No.
CHDC-C-004

Attach the swivel pulley, w/ attached eyebolt and hoisting rope assembly, (Item Nos. 5, 6, 17, 18, & 20) to the top hole of the upright using a 5/16"-18 hex nylon lock nut (Item No. 19). (If there are 2 holes present at the top of the upright, mount the pulley and eyebolt through the **top** hole.)

Attach the fixed pulley (Item no. 6) through the middle set of holes

CHDC
NCAA HAMMER-DISCUS CAGE
LAYOUT AND INSTALLATION INSTRUCTIONS

using 1/4"-20 x 4-1/2" hex bolts (Item No. 7) and 1/4"-20 hex nylon lock nuts (Item No. 10).

Attach one cleat (Item No. 8) through the lower set of holes using 1/4"-20 x 5-1/2" hex bolts (Item No. 9) and 1/4"-20 hex nylon lock nuts (Item No. 10). Cap threads with 1/4" -20 acorn nuts (Item No. 11). Secure the hoisting rope to the cleat.

After concrete cures, insert assembled upright into ground sleeve. Repeat procedures to assemble remaining uprights.

Step No. 8
Rotating Gate
Assembly

See Drawing No.
CHDC-C-003 &
HDC-C-001

Lay entire assembled gate horizontally on carpenter's horses. Attach Gate Extension Arms (Item No. 22) to the top and bottom of the Main Gate Frame (Item No. 21) using 1/2" hardware listed (Item Nos. 14, 15, & 16).

Attach Gate Extension Cable assembly (Item No. 28) by placing the 3/8"-16 x 6" closed eyebolts in the holes at the ends of the Gate Extension Arms and securing with a 3/8" flat washer and 3/8"-16 hex nylon lock nuts. Adjust and tighten if necessary.

Attach 12" caster (Item No. 23) to the bottom of Gate Main Frame using 3/8" hardware listed (Item Nos. 24, 25, & 26) (See drawing No. HDC-C-001). Open and spread out gate net envelope, and slide the open part of the envelope over the top, and down the gate. Use zip ties, positioned every 6"-8", to close the bottom of the gate net around the bottom of the gate.

Attach the Vertical Gate Post Cable Assembly (Item No. 27) to the pivot post of the rotating gate by placing the pre-assembled post collar-cable assembly around the post on the inside of the net, at the top of the post, leaving the cable outside of the net. Install the other collar just below the bottom of the gate (about 52" from the bottom of the post), attach the cable to the bottom collar, and tighten in place. Tension the cable using the turnbuckle at the bottom of the cable, being sure the cable runs up the throwing side of the gate (with the rubber facing) on the outside of the net. Adjust and tighten as necessary.

Using a mechanical hoisting device, crane, or a front-end loader, (after concrete has cured) raise the assembled gate until it is perfectly perpendicular to the ground, and slowly lower the main post of the rotating gate into the ground sleeve. Use the included shims (Item No. 33) to adjust the height of the 12" caster so it remains in contact with the concrete pad through the gate's entire range of motion (See drawing no. HDC-C-001).

Repeat entire procedure to erect and install the other gate.

Step No. 9

Lower hoisting ropes on each post so the pear clip is reachable.

CHDC
NCAA HAMMER-DISCUS CAGE
LAYOUT AND INSTALLATION INSTRUCTIONS

Main Net
Installation

Attach a cable clamp and O-ring (Item Nos. 34 & 35) to the cable woven into the top of the main net (Item No. 2) at each hoisting location, marked by a red stripe (See drawing no. CHDC-C-002 for distances between hoisting locations if a red stripe is missing). Clip each post's pear clip to the O-ring at its respective hoisting location.

Raise the main net, and subsequently attach each front edge of the net to the Vertical Gate Post Cable Assembly using the zip-ties provided (spaced EVERY 6 in.) Zip-ties attach the net to the cable, but slide easily to allow the net to be raised and lowered. **DO NOT** over-tighten zip-ties!

Raise the net all the way by the hoisting rope and secure the end of the rope firmly and professionally to the cleat. (Consult former Navy personnel or handbook for proper method.)

With the net fully raised, use an extension ladder or lift to install one Galvanized Post Collar (Item No. 39) halfway up each gate post (10'). As with the top and bottom collars, place it inside the net with the bolt flange sticking out. Place the Vertical Gate Post Cable between the two flanges and between the bolt and the post, securing it in place close to the gate post.

Clip the bottom cable of the net to the eyebolts at points A-H. Attach the bottom of the net to the Ground Cable Assembly (Item No. 36) using the provided zip-ties spaced about every 12"-18" around the perimeter of the net.

Step No. 10
Horizontal Pull-
Back Cable
Installation

See Drawing No.
CHDC-C-002

Install a Galvanized Post Collar (Item No. 39) at a height of 78" on each of the gate posts with the bolt side facing the back of the cage. Clip one end of the Horizontal Pull-Back Cable (Item No. 37) to the bolt on the Galvanized Post Collar on gate post "L" using a Pear Clip (Item No. 20). Weave the cable through three or four squares of the Main Net (Item No. 2). Run the cable along the inside (throwing side) of the net to point "F". Weave the cable through three or four squares of the Main Net at point "F". Repeat for each subsequent point, making sure to run the cable between points on the inside of the net. Clip the other end of the cable to the collar on the other gate post ("K") using a Pear Clip.

Attach a Galvanized Post Collar (Item No. 39) to upright nos. "1"- "6" at a height of 78". Clip one pear clip from each Net Retractor (Item No. 38) to the collar on each of the uprights. Clip the other pear clip to the Net Retractor Cable Assembly at points "A" thru "F" where the cable is woven through the net.

OPTIONAL
Barrier Net
Installation

Screw in eyebolts (Item No. 31) into threaded inserts located on the rear of each main upright (2 per upright). Clip the top and bottom of net to the eyebolts with pear clips (Item No. 20) at each location

CHDC
NCAA HAMMER-DISCUS CAGE
LAYOUT AND INSTALLATION INSTRUCTIONS

(Purchased separately)

marked with a red stripe. Any excess net may be wrapped around the end upright. Use two Galvanized Post Collars (Item No. 39) per upright on upright nos. "7" & "8" to hold the backup net to the post. Space the collars about every 32" between the two backup net eyebolts. Loop the collar through the net and clamp it tight to the post. This keeps the net tight on the post to ensure safety and give a consistently clean look.

OPERATION, CARE, AND SPECIAL INSTRUCTIONS

1. When cage is not in use, gates should be closed and loosely attached to one another. Be sure the wheel brakes are OFF to allow the gates to move and absorb wind forces safely.
2. NEVER pin or lock the gates in place as this can result in damage to the lock, the concrete pad, or the gate itself due to wind.
3. When the cage is in use, use the wheel brakes to hold the gates in the appropriate position for the throwing event. Wheel brakes should always be ON during use to prevent unwanted gate movement.
4. In the event of high winds, lower the Main Net and Barrier Net. DO NOT use the cage and keep out of the throwing area in high wind conditions.
5. During the off-season, removal and storage of the Main Net, Gate Nets and Barrier Net will prolong the life of the nets. Nets should be stored in a sealed drum (See AAE Model No. ND-P Net Drums) in a dry location to protect them from moisture and pests.

FOR TECHNICAL ASSISTANCE, CALL 1-800-523-5471

K:\AAE Data\PDF Files\Z-Product Instructions & Parts Lists\Track & Field\CHDC\CHDC Assembly Instructions.doc
Copyright © 2012 Aluminum Athletic Equipment Co.