

AAE Model No. FBS-35
35' Football BallStopper System
Specification

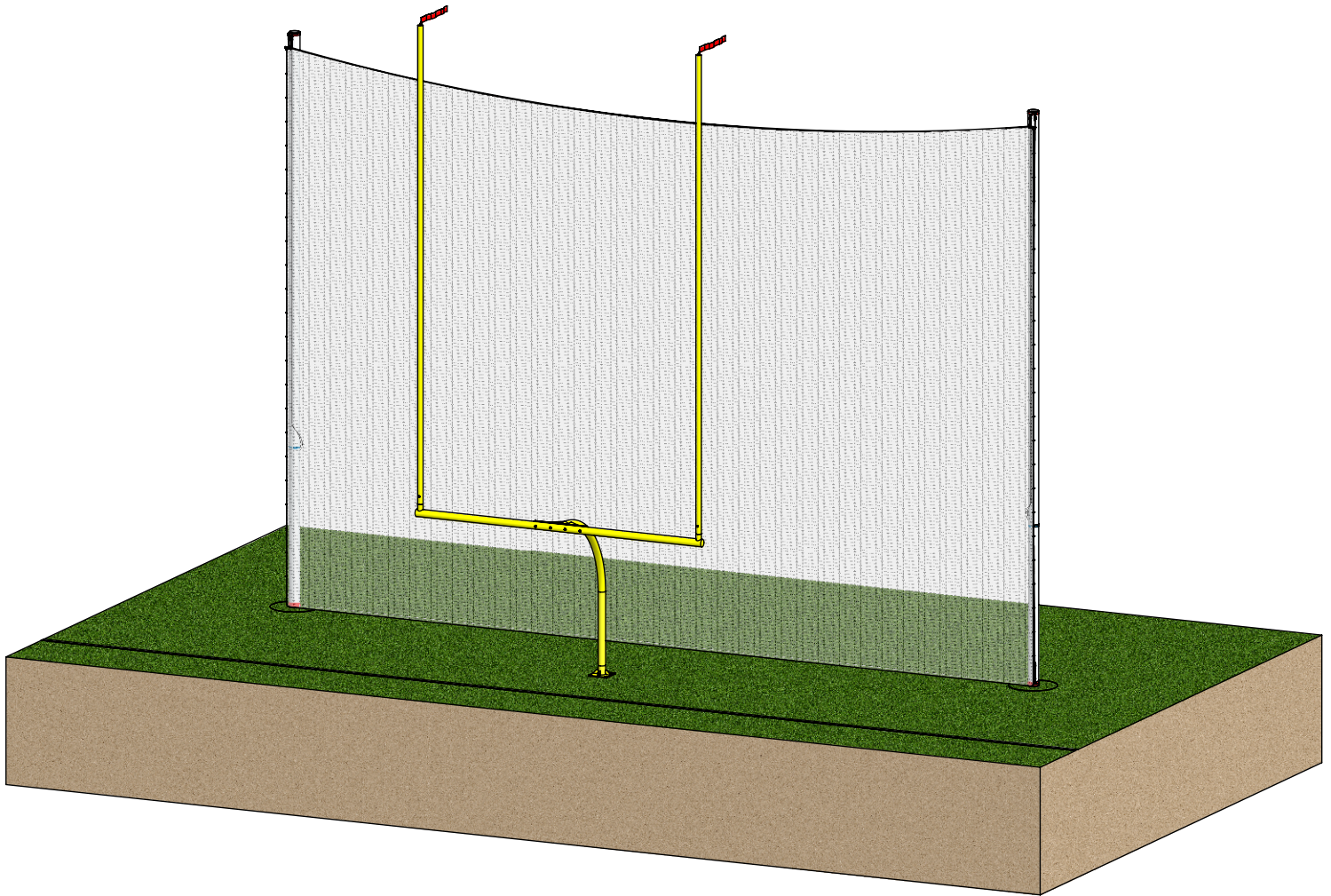

FBS-35 Specifications

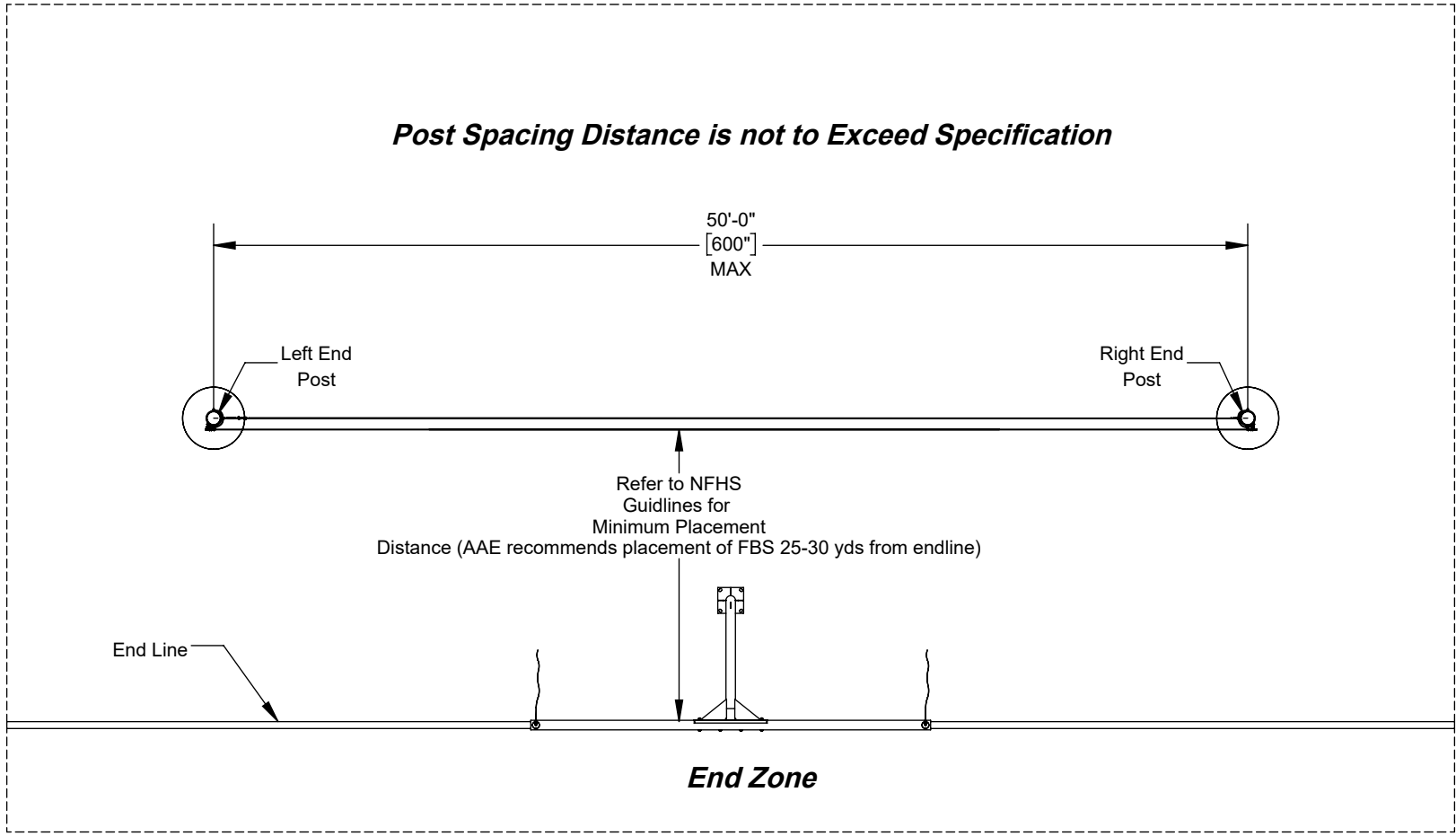

Aluminum Athletic Equipment
1000 Enterprise Drive, Royersford, PA 19468
Toll Free: (800) 523-5471 Fax: (610) 825-2378
www.AAEsports.com

DESCRIPTION:		
Concrete Footing Placement Specification		
NOTE:		
35' HIGH BALLSTOPPER SYSTEM		
MODEL:	CATEGORY:	DATE:
FBS-35	CUSTOMER	4/22/2021
DWN. BY:	CAD FILE:	DWG. NO.:
N.R.	FBS-35 Specifications	FBS-35-C-002

FBS-35 Upright Specification

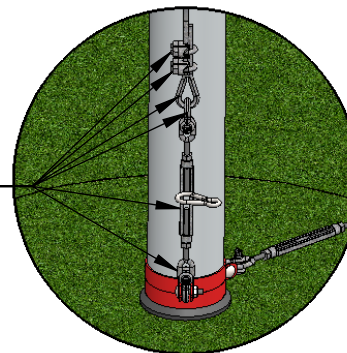
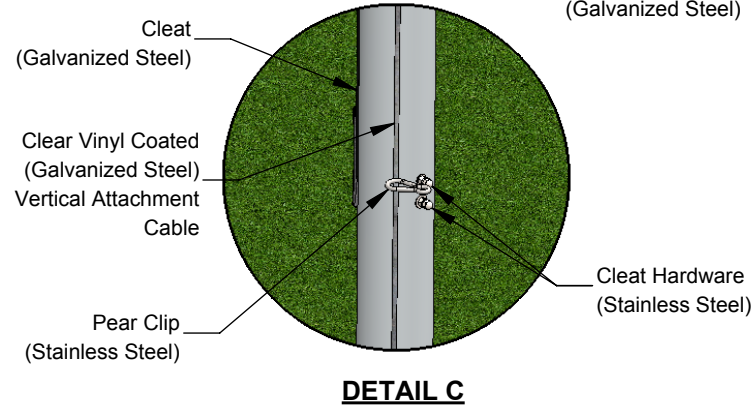
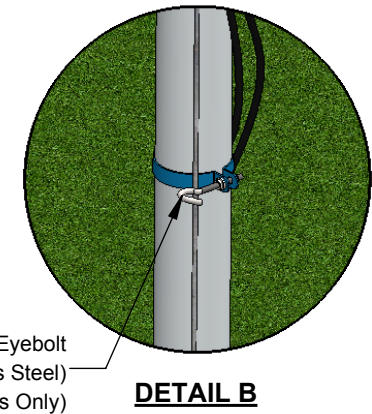
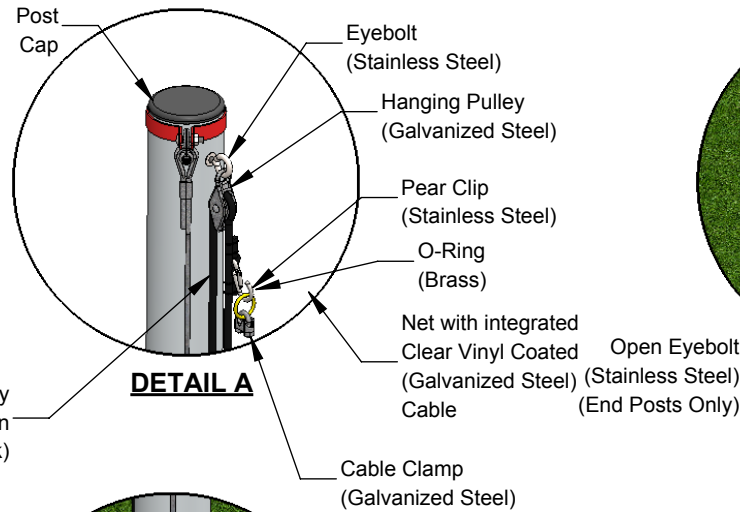
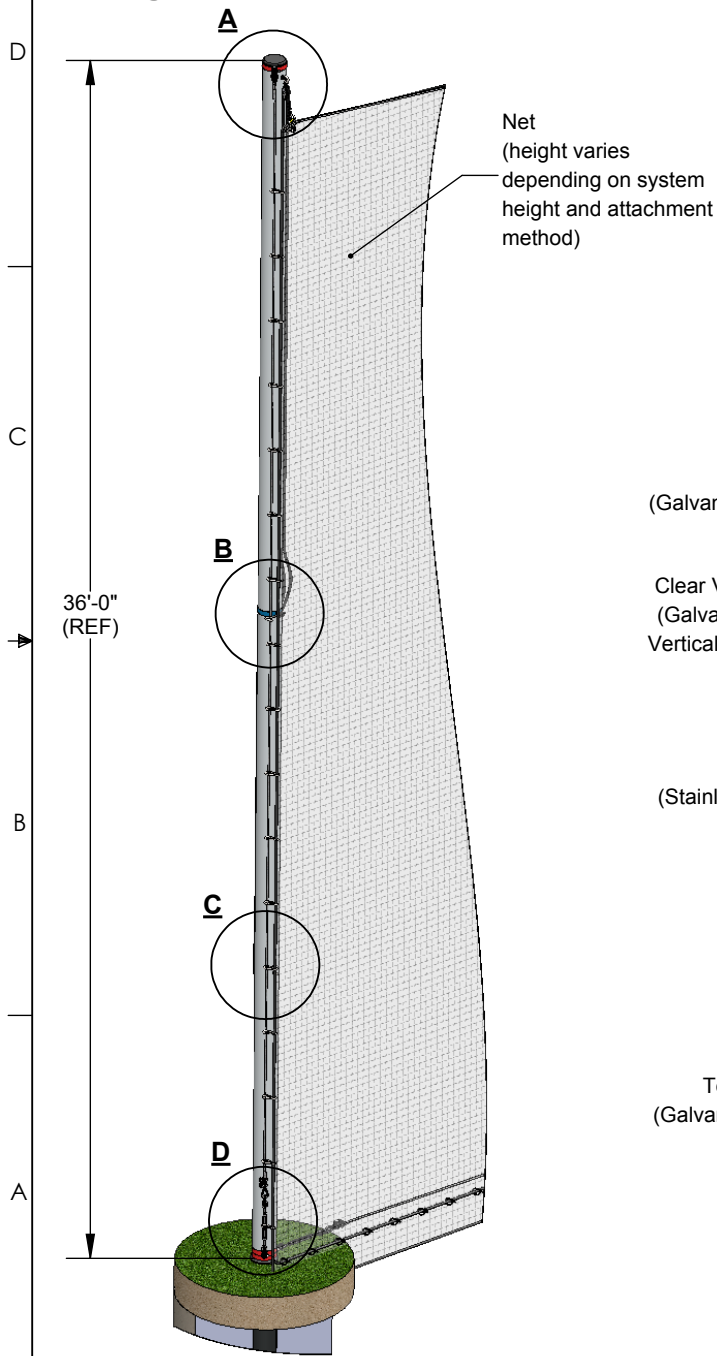

FBS-35 Specifications

Post (Aluminum):

- $\varnothing 8'' \times .188''$ wall aluminum tube (Mill Aluminum 6061T6)
- 40'-6" Overall Length (36'-0" out of ground sleeve)
- Weight = 219lbs./ea.
- All Hardware is RUSTPROOF

Netting:

- Net: #AAE N864, 3-1/2" Sq. Knotted Black Nylon, UV-treated, 360# tensile strength, 1/4" MFP rope border, pre-attached sewn in 3/16" dia. clear coated galvanized cable

 Aluminum Athletic Equipment 1000 Enterprise Drive, Royersford, PA 19468 Toll Free: (800) 523-5471 Fax: (610) 825-2378 www.AAEsports.com			
DESCRIPTION			
FBS-35 Upright Specification			
NOTE: Upright Assembly Specification			
MODEL:	FBS-35	CATEGORY:	CUSTOMER
		DATE:	4/11/2018
DRAWN BY:	CED	DWG. NO.:	FBS-35-C-003
			FBS-35 Specifications

FBS-35 Concrete Footing Specification

Natural Grass Field Footing Specification

Artificial Grass Field Footing Specification

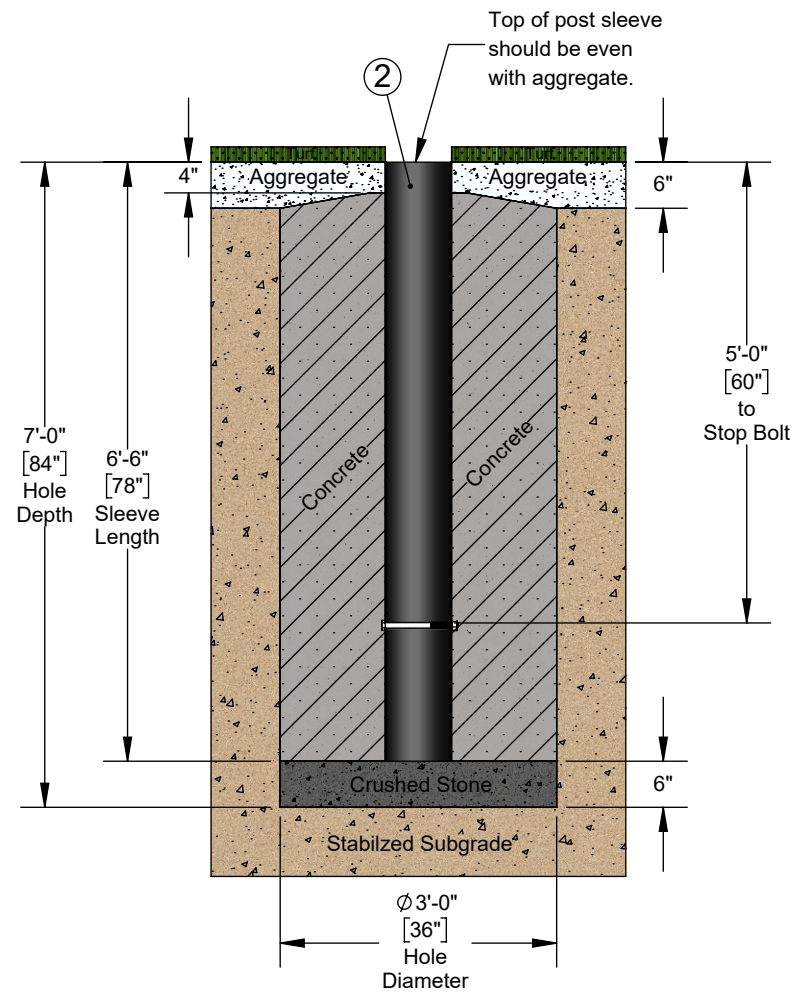
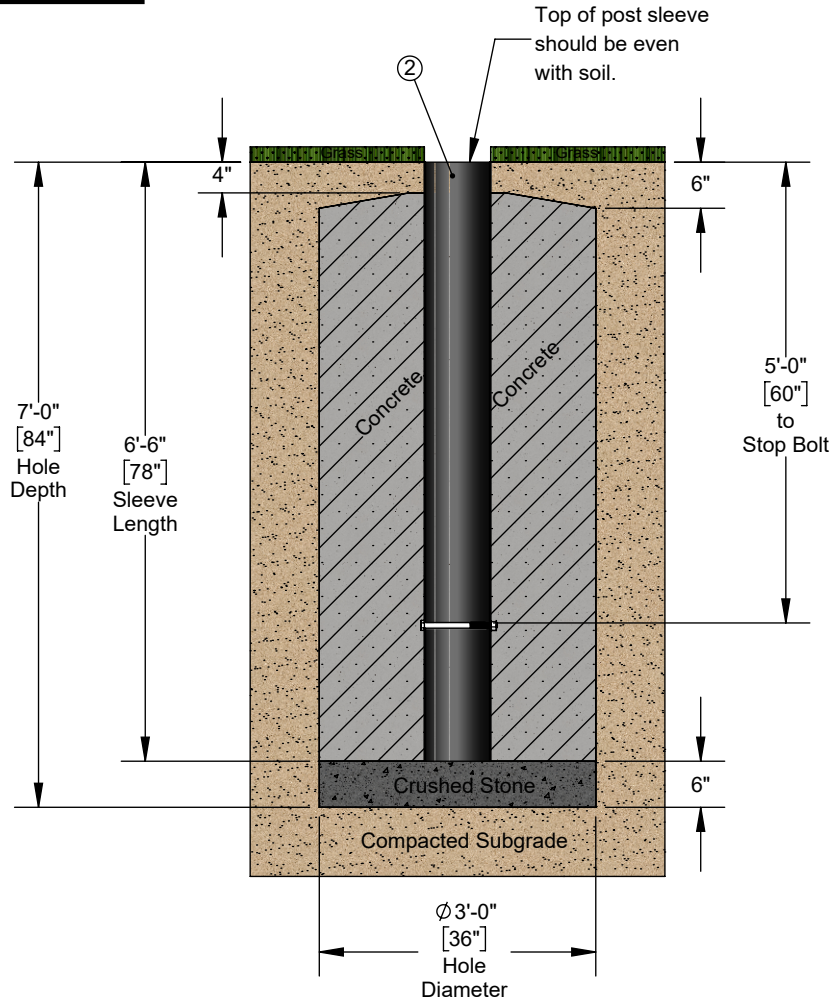

Note: **Consult Local Codes



Aluminum Athletic Equipment
1000 Enterprise Drive, Royersford, PA 19468
Toll Free: (800) 523-5471 Fax: (610) 825-2378
www.AAEsports.com

DESCRIPTION		
Concrete Footing Specification		
NOTE: Grass & Turf Footing Specification		
MODEL: FBS-35	CATEGORY: CUSTOMER	DATE: 4/22/2021
DRAWN BY: N.R.	CAD FILE: FBS-35 Specifications	DWG. NO. FBS-35-C-004

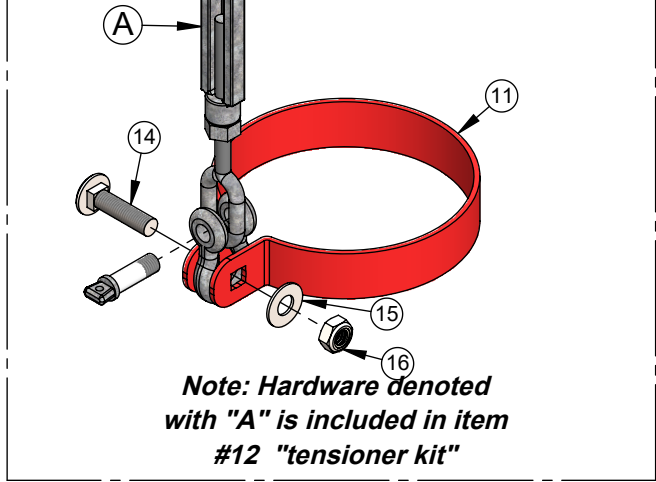
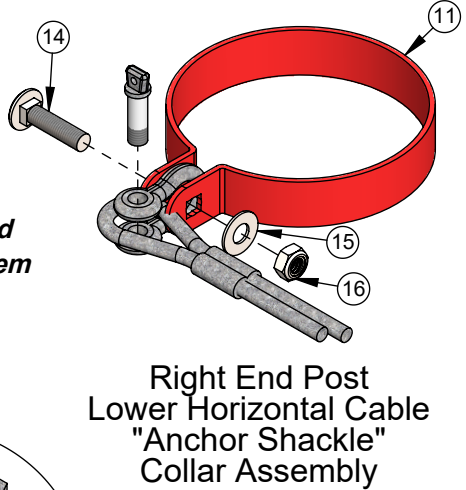
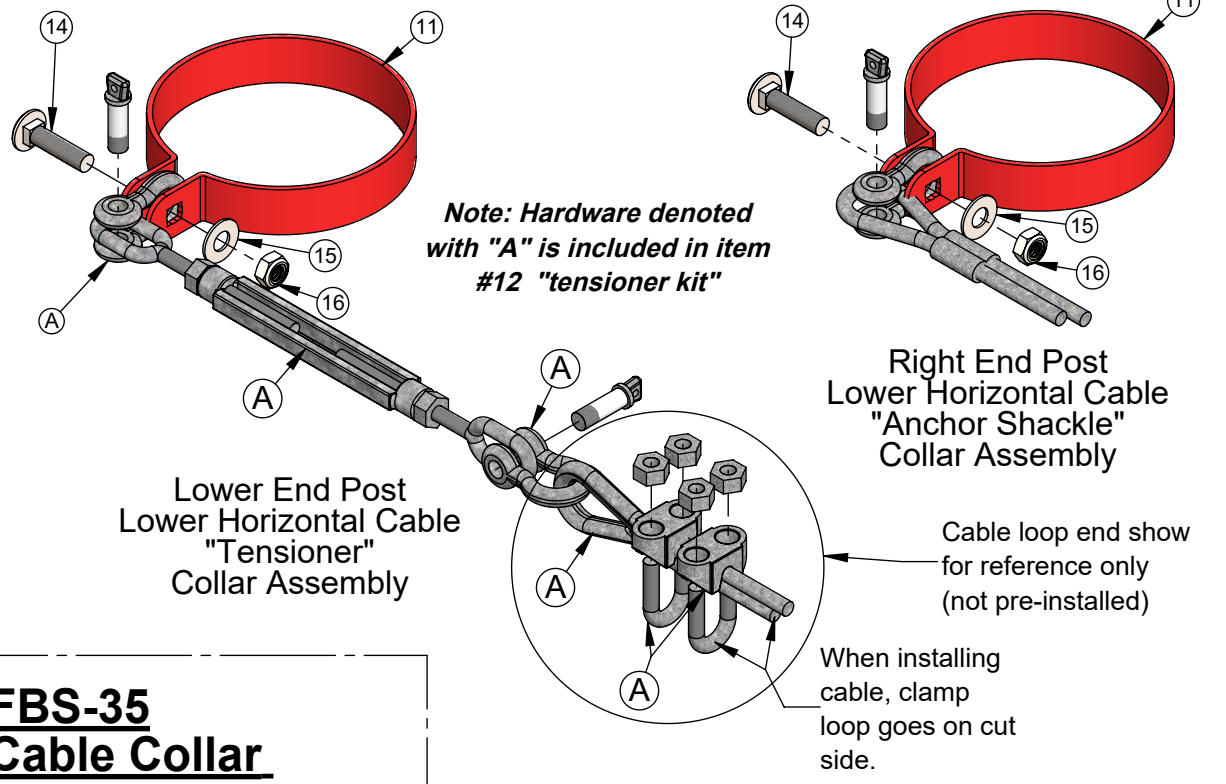
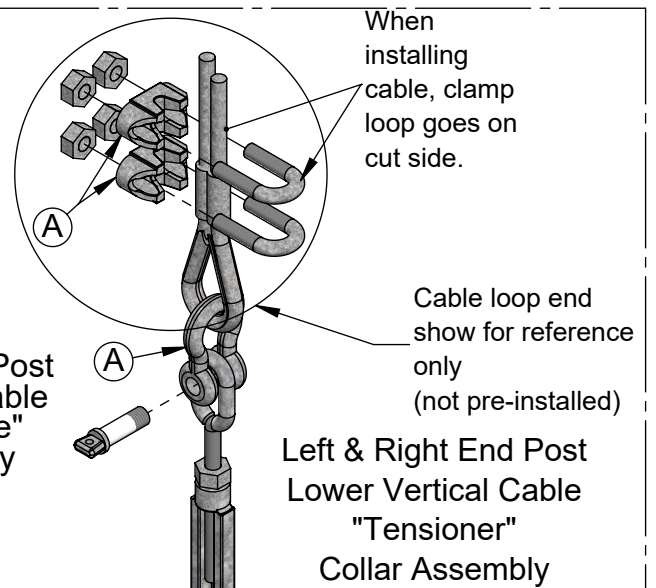
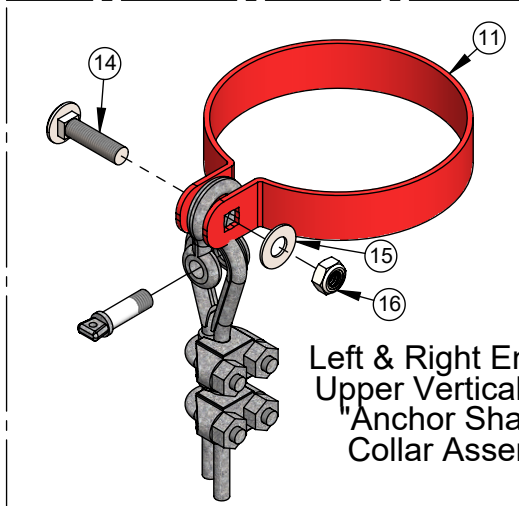
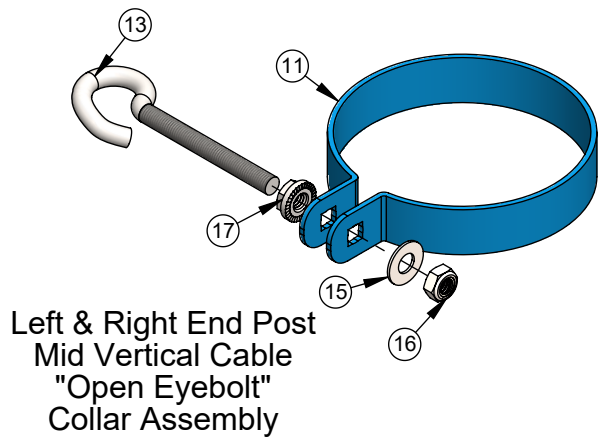

FBS-35 Cable Collar Assembly Diagrams

 Aluminum Athletic Equipment 1000 Enterprise Drive, Royersford, PA 19468 Toll Free: (800) 523-5471 Fax: (610) 825-2378 www.AAEsports.com			
DESCRIPTION			
FBS-35 Assembly Instructions			
NOTE: Various Collar Assemblies			
MODEL:	FBS-35	CATEGORY:	CUSTOMER
DATE:	4/22/2021		
DRAWN BY:	NR	CAD FILE:	FBS-35 Specifications
DWG. NO.:	FBS-35-C-005		

FBS-35 Assembly Instruction Left End Post

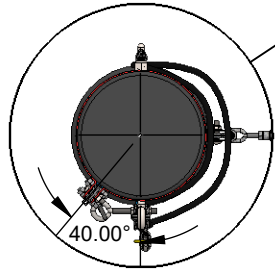

**Collar Orientation
Detail**

(Note: **ONLY** vertical cable collars should be turned away from netting)

Installation Notes:

- Lower Collars:** From bottom of pole slide the lower vertical cable collar, lower horizontal collar and debris ring (optional) into position. To allow proper insertion into ground sleeve, lower most collar should be 60" from end of post. Before securing collars into place make sure to rotate the lower vertical collar approx 40°. (refer to diagram)
- Cleat:** Is to be installed so that it is on backside of post, opposite net. Screws will be inserted through cleat and post and secured on net side using flat washers, Nylock hex-nuts and cap nuts. (refer to diagram)
- Mid Collar:** Note orientation of collar on post. From top of pole slide the open eyebolt collar into position (refer to diagram) and secure into place.
- Eyebolt:** Pulley system comes preassembled to eyebolt. Install washer onto eyebolt then insert eyebolt with washer through front side of hole at top of post. From opposite side secure eyebolt into place using a flatwasher and self-locking hex-nut. (refer to diagram)
- Upper Collar:** From top of pole slide the upper vertical cable collar into position (collar should rest on eyebolt washers). Before securing into place make sure to rotate the collar approx 40°. (refer to diagram)
- Make sure warning labels are present on goal posts.

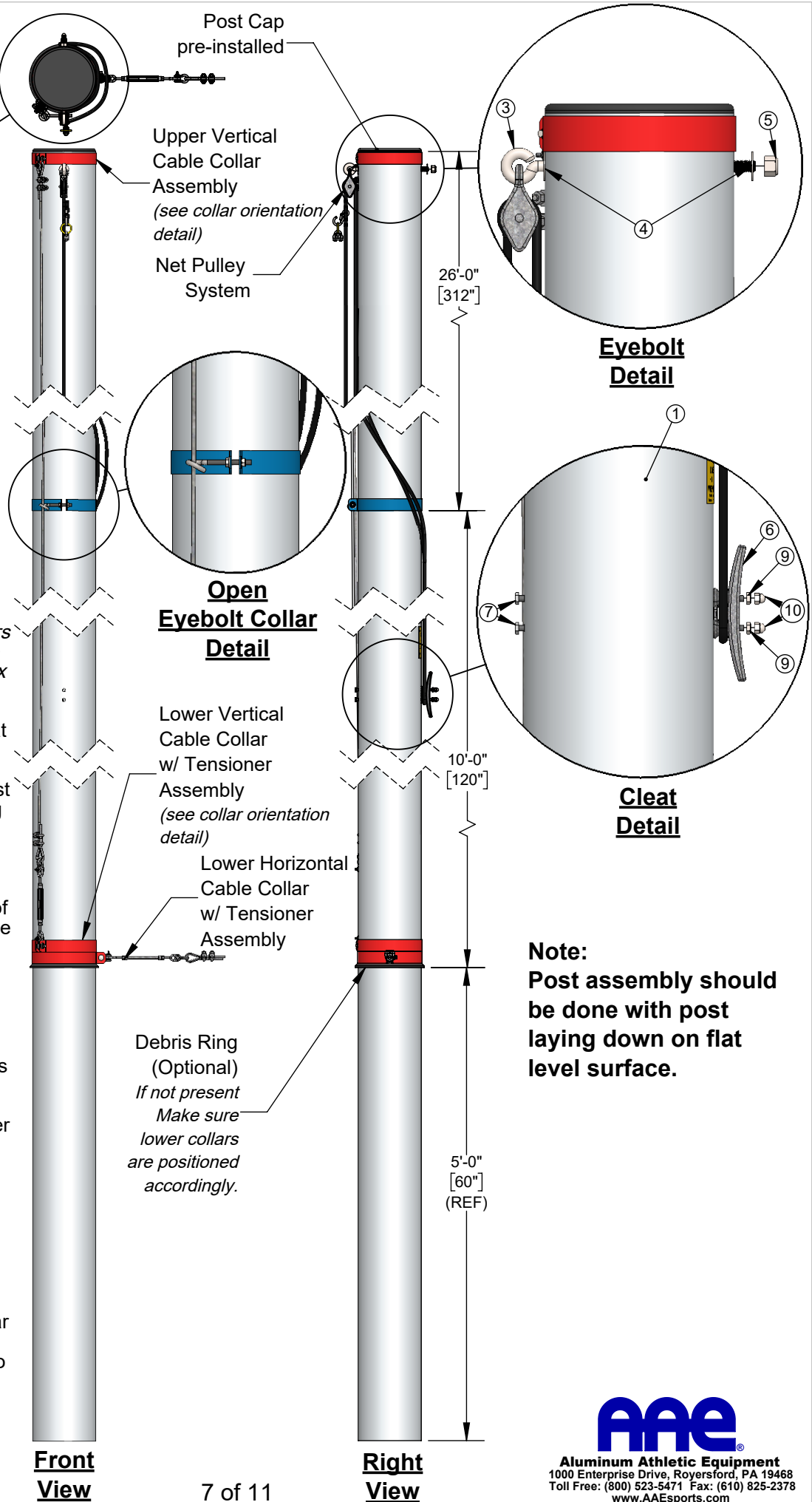

Note:
Post assembly should be done with post laying down on flat level surface.



Aluminum Athletic Equipment
1000 Enterprise Drive, Royersford, PA 19468
Toll Free: (800) 523-5471 Fax: (610) 825-2378
www.AAEsports.com

FBS-35 Assembly Instruction Right End Post

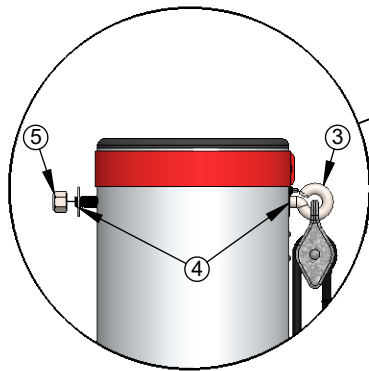

**Eyebolt
Detail**

Installation Notes:

- Lower Collars:** From bottom of pole slide the lower vertical cable collar, lower horizontal collar and debris ring (optional) into position. To allow proper insertion into ground sleeve, lower most collar should be 60" from end of post. Before securing collars into place make sure to rotate the lower vertical collar approx 40°. (refer to diagram)
- Cleat:** Is to be installed so that it is on backside of post, opposite net. Screws will be inserted through cleat and post and secured on net side using flat washers, self locking hex-nuts and cap nuts. (refer to diagram)
- Mid Collar:** Note orientation of collar on post. From top of pole slide the open eyebolt collar into position, refer to dimension provided and secure into place.
- Eyebolt:** Pulley system comes preassembled to eyebolt. Install washer onto eyebolt then insert eyebolt with washer through front side of hole at top of post. From opposite side secure eyebolt into place using a flatwasher and Nylock hex-nut. (refer to diagram)
- Upper Collar:** From top of pole slide the upper vertical cable collar into position (collar should rest on eyebolt washers). Before securing into place make sure to rotate the collar approx 40°. (refer to diagram)
- Make sure warning labels are present on goal posts.

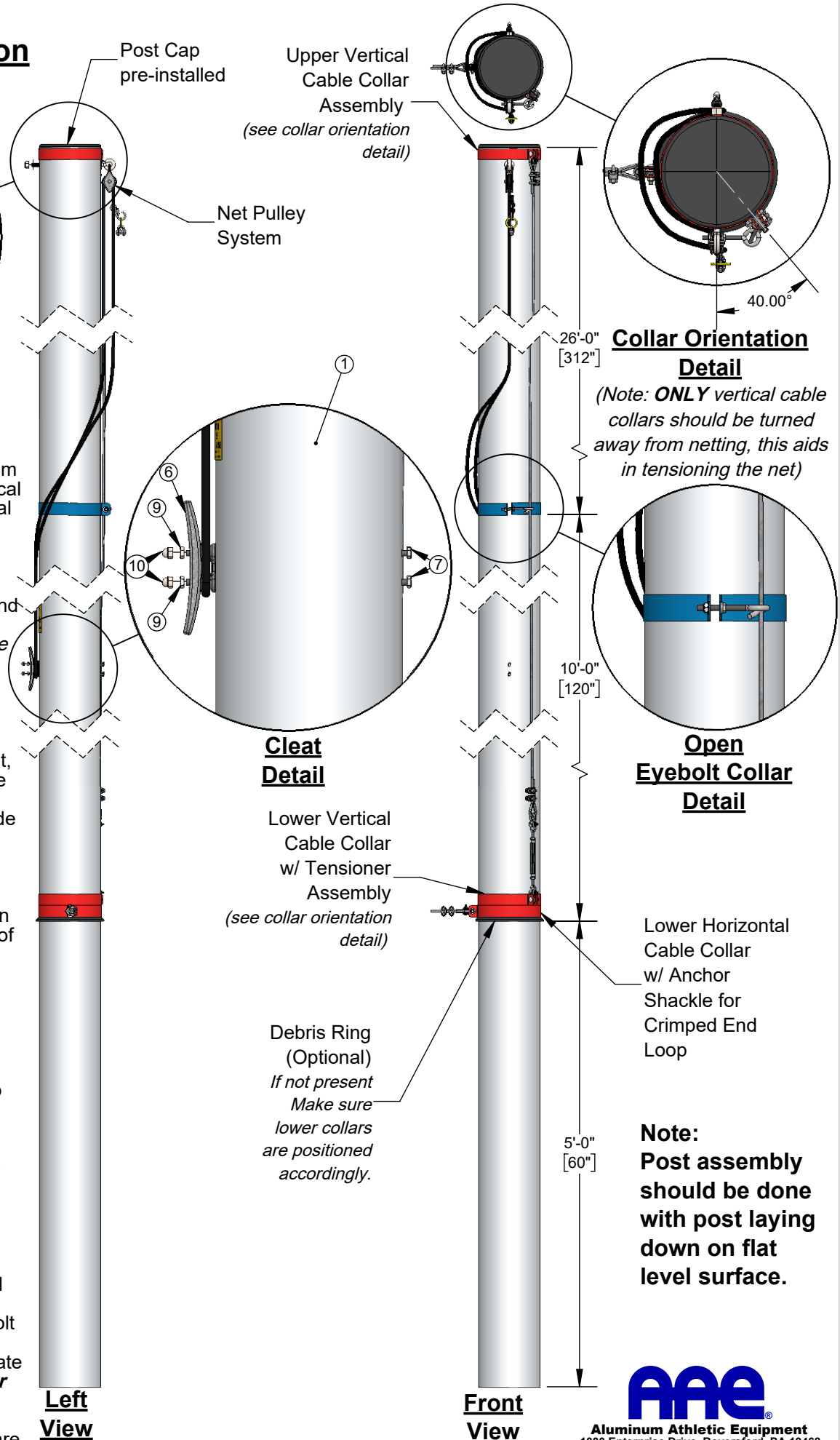

Note:
Post assembly should be done with post laying down on flat level surface.



Aluminum Athletic Equipment
1000 Enterprise Drive, Royersford, PA 19468
Toll Free: (800) 523-5471 Fax: (610) 825-2378
www.AAEsports.com

FBS-35

Assembly Instruction

Posts to Groundsleeve

Note: Height & number of inner posts may vary from what is shown.

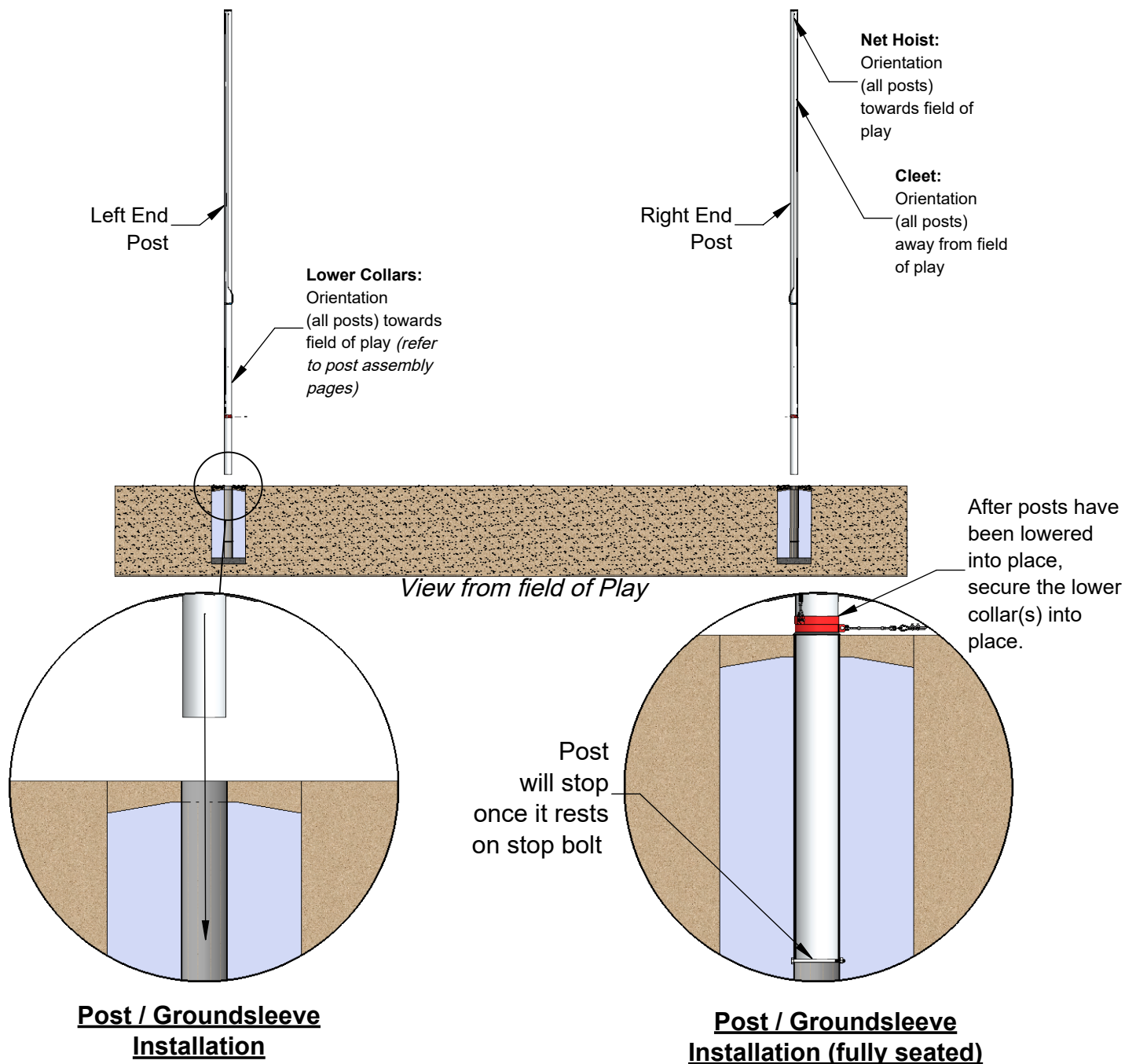

Installation Notes:

1. View above is from net side of post (*field of play*).
2. **Caution**, slowly lower posts into sleeves. Dropping post into sleeve may result in damage to the stop bolt.
3. Make sure all posts are orientated correctly. Pulley system towards field of play and cleet away from field of play. All lower horizontal cable collars should face field of play.
4. Once posts are correctly orientated, make sure the lower collars are properly orientated and secure them into place.

FBS-35

Assembly Instruction

Lower Horizontal Support Cable

View from field of Play

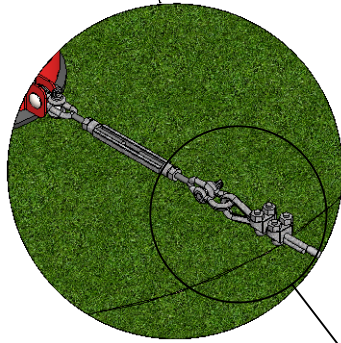
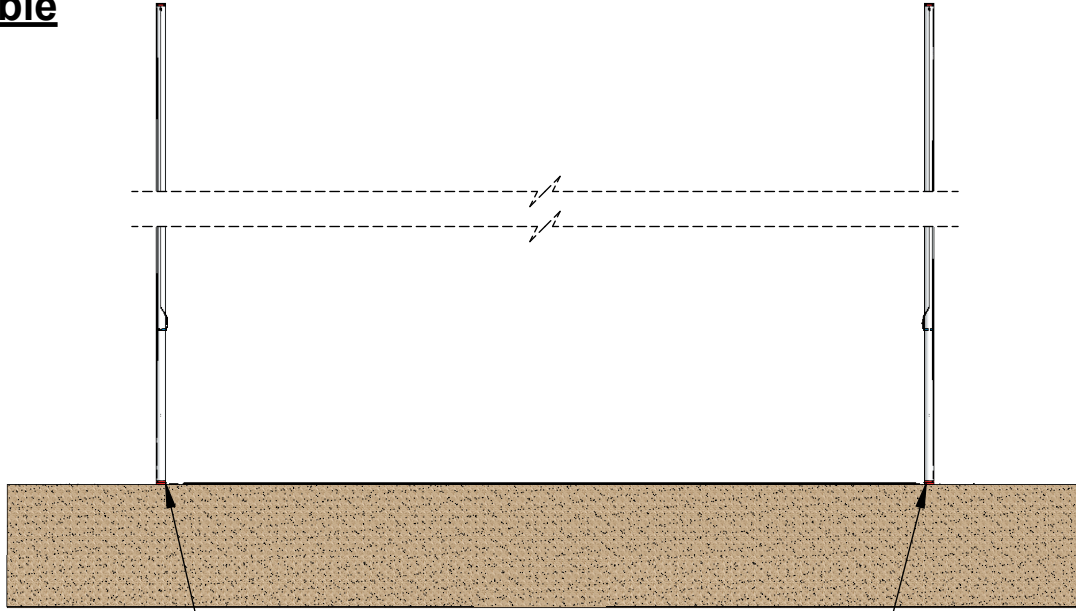

Left End Post
(Clamped Loop End)

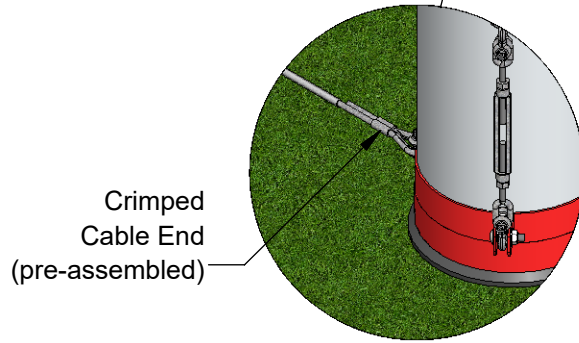

Right End Post
(Crimped Loop End)

Installation Notes:

1. Refer to collar assembly diagram for further detail on collar and cable assembly.
2. Install Crimped Cable End to Right End Post collar using an anchor shackle.
3. Route cable to Left End Post. Snap cable into Pear Clips of the Inner Posts along the way
4. Before assembling Clamped Cable Loop End, fully open the turnbuckle.
5. With anchor shackle and thimble in place run cable thru the shackle as shown. Pull slack out of cable and mark vinyl sleeve approximately 4" from thimble end. Strip vinyl from mark location towards cable loop end.
6. With the slack still being pulled out of cable install and secure the cable clamps. The first clamp should butt upto the thimble, the second should be spaced approx. 1" on center from the first. Cable clamps must be gripping bare cable to ensure proper seating/grip.

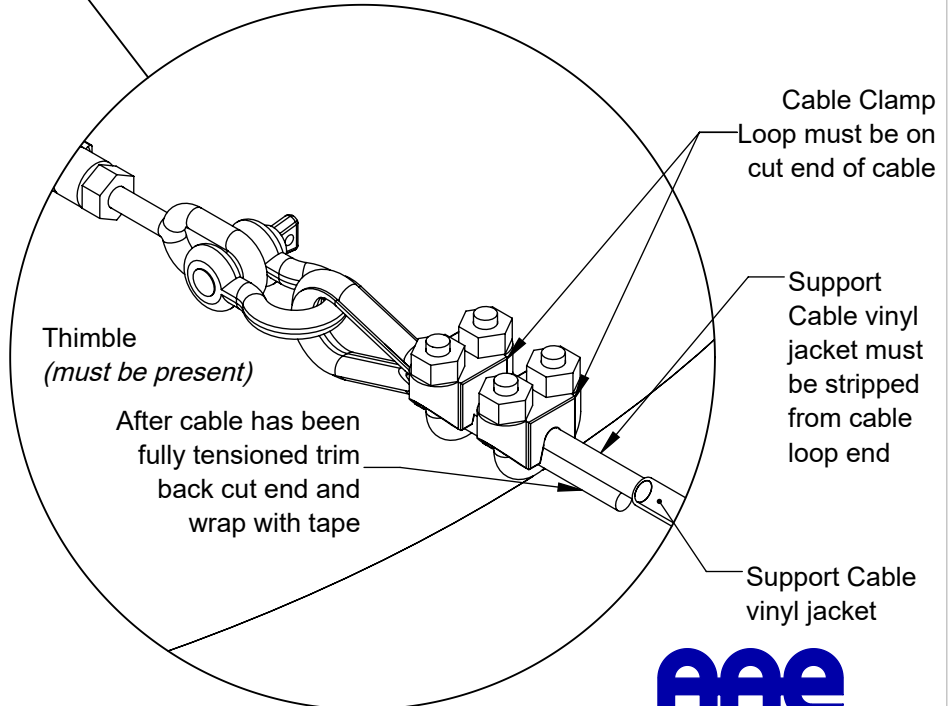

Clamped Loop End
Detail

FBS-35

Assembly Instruction

Net Attachment

Note: When raising net, it must be done in increments across the entire span

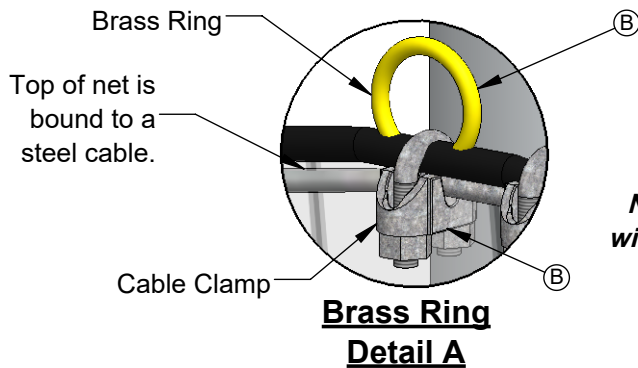
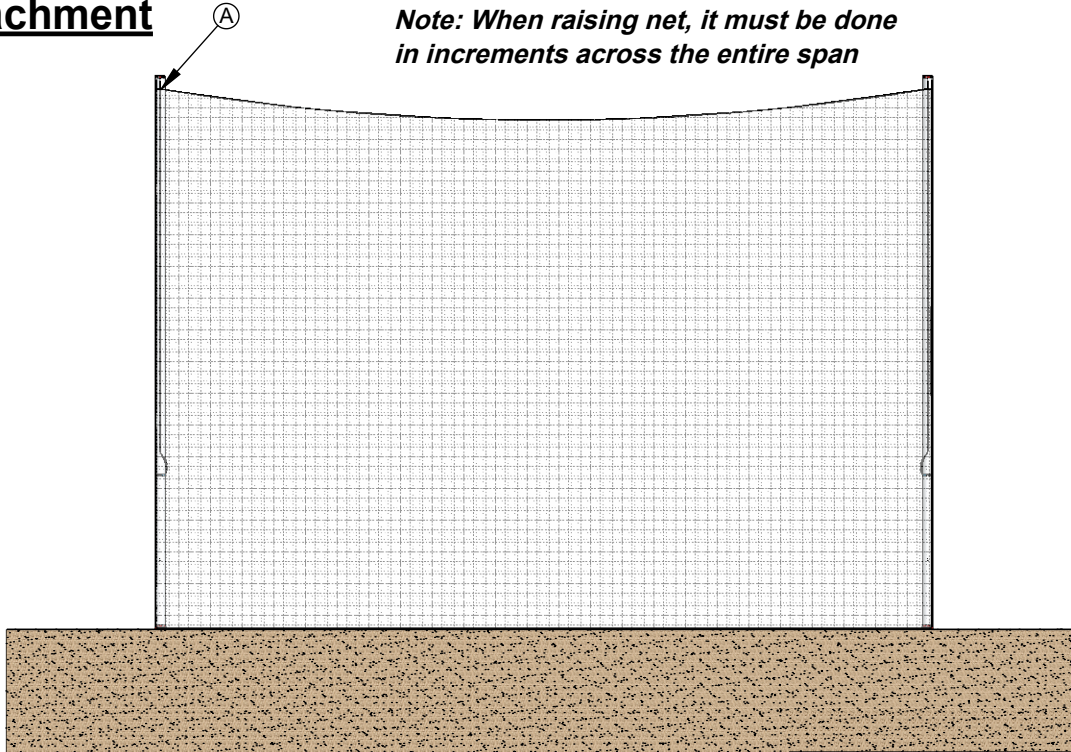

Note: Hardware denoted with "B" is included in item #3 "Hoist Rope"

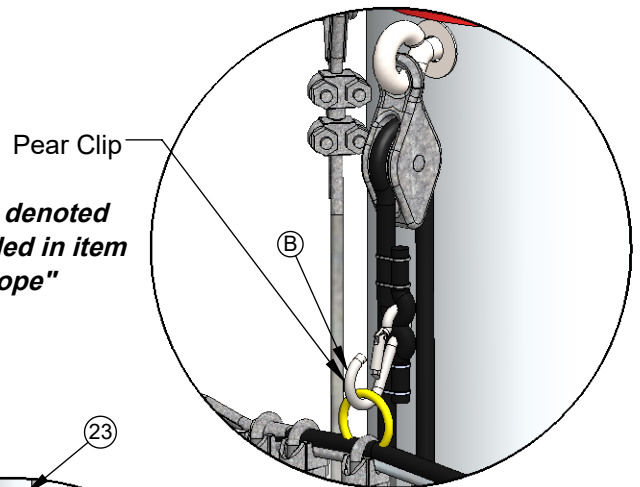

Installation Notes:

1. Lay net on ground across span of posts. *Make sure net is centered across span of posts.*
2. Using a Pear Clip Secure upper net corners to End Post Vertical Support Cables *(as shown in Detail C)*
3. Secure Brass Rings to top of net using Cable Clamp *(as shown in Detail A)*. One ring and clamp per post and they should be centered as close as possible to its coinciding post.
4. After Brass Rings have been secured to net, clip ring into it's posts hoist system Pear Clip *(as shown in Detail B)*.
5. As net is being raised make sure to secure net sides to the vertical support cables using provided **Pear Clips** *(refer to Detail C)*. Pear Clips should be spaced approx. 12" or 9 net squares.
6. Once net has been completed raised tie hoist ropes onto cleat.

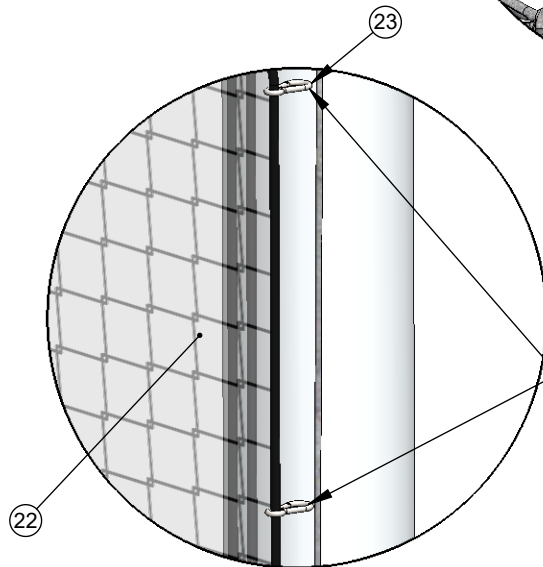

Pear Clips Spaced approx. every 12", entire length of vertical cable **(Left and Right End Posts Only)**

Net to End Post Vertical Support Cable Detail C