

AAE Model No. FP-R & FP-P Fence Pad - Rail & Post

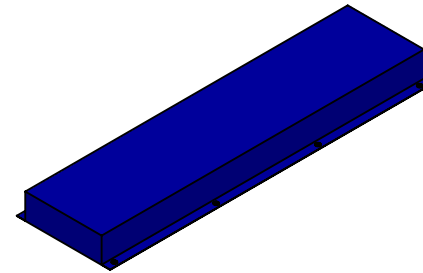
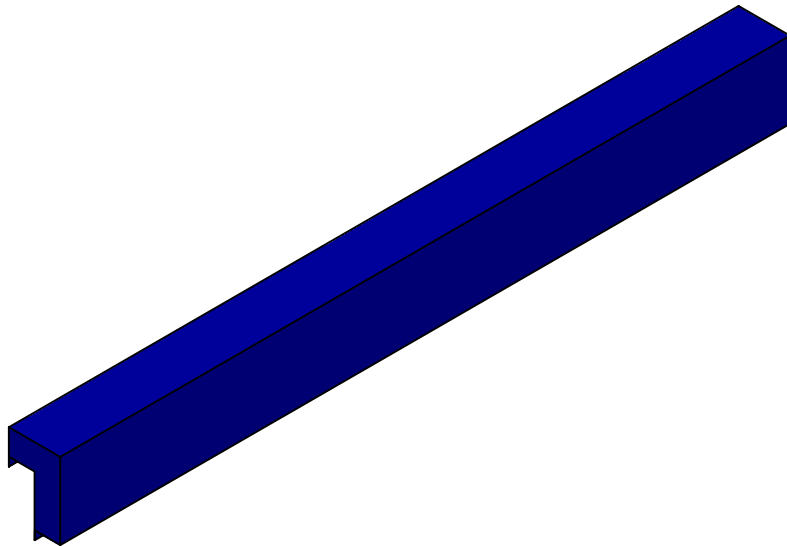

Aluminum Athletic Equipment
1000 Enterprise Drive, Royersford, PA 19468
Toll Free: (800) 523-5471 Fax: (610) 825-2378
www.AAEsports.com

FP - Fence Pad Specifications

FP-R-9/3: Fence Pad - Rail

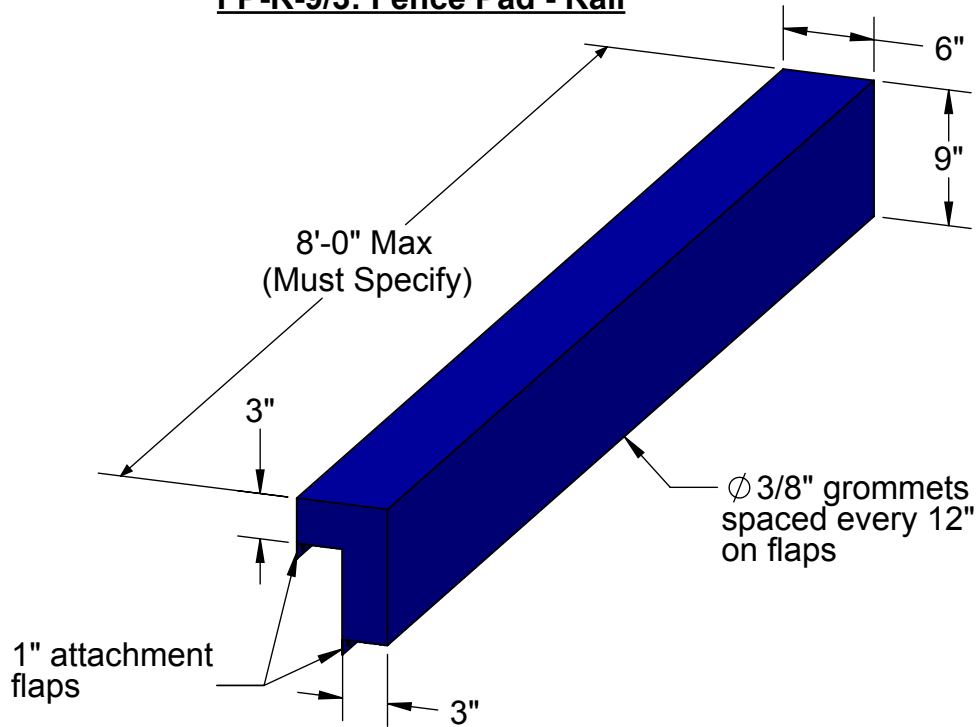

FP-P-9/3: Fence Pad - Post

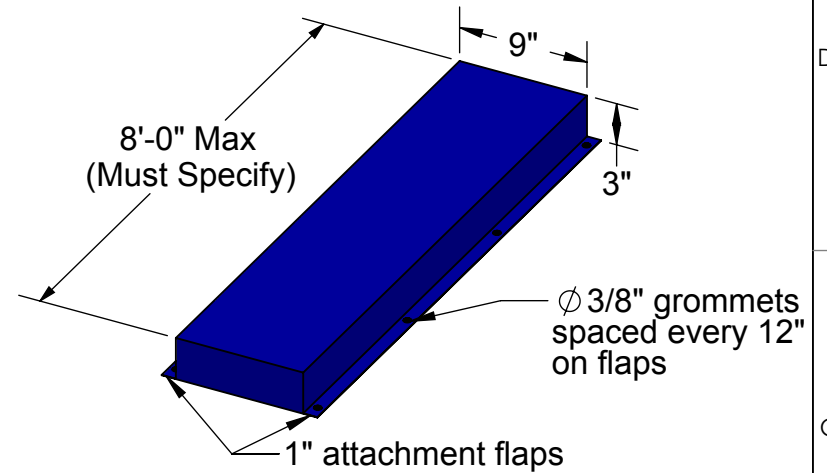

Notes:

- 18oz. double knife-coated, UV stabilized vinyl covered foam pads for use on existing chain-link fences
- Attach to fence by looping included zip-ties through the fence and grommets in the pad
- Pads come in color of choice (as specified)

AAE Model No. FP-P-9/3: Fence Pad-Post

- 9" W x 3" T, length as specified
- AAE Model No. FP-R-9/3: Fence Pad-Rail
- 9" H x 3" T x 6" D top, length as specified

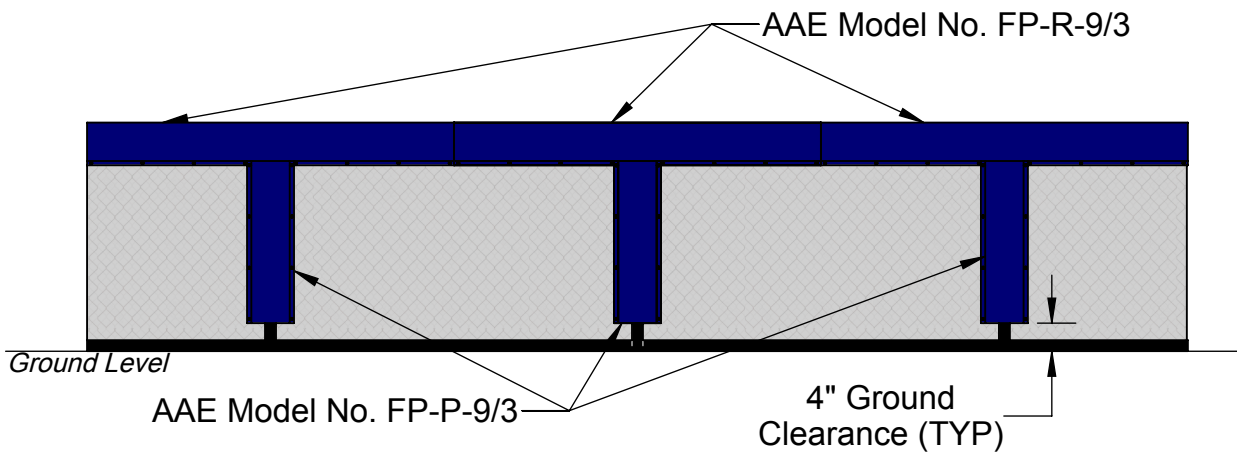

Aluminum Athletic Equipment
 1000 Enterprise Drive, Royersford, PA 19468
 Toll Free: (800) 523-5471 Fax: (610) 825-2378
www.AAEsports.com

DESCRIPTION:			FP - Fence Pad
NOTE:			FP-P-9/3 & FP-R-9/3 Specifications
MODEL:	CATEGORY:	DATE:	
FP-P-9/3 & FP-R-9/3	CUSTOMER	01/25/12	
DWN. BY:	CAD FILE:	DWG. NO.:	
ARP	FP Spec Drawing	FP-C-001	