

AAE Model No. HSDC High School Discus Cage

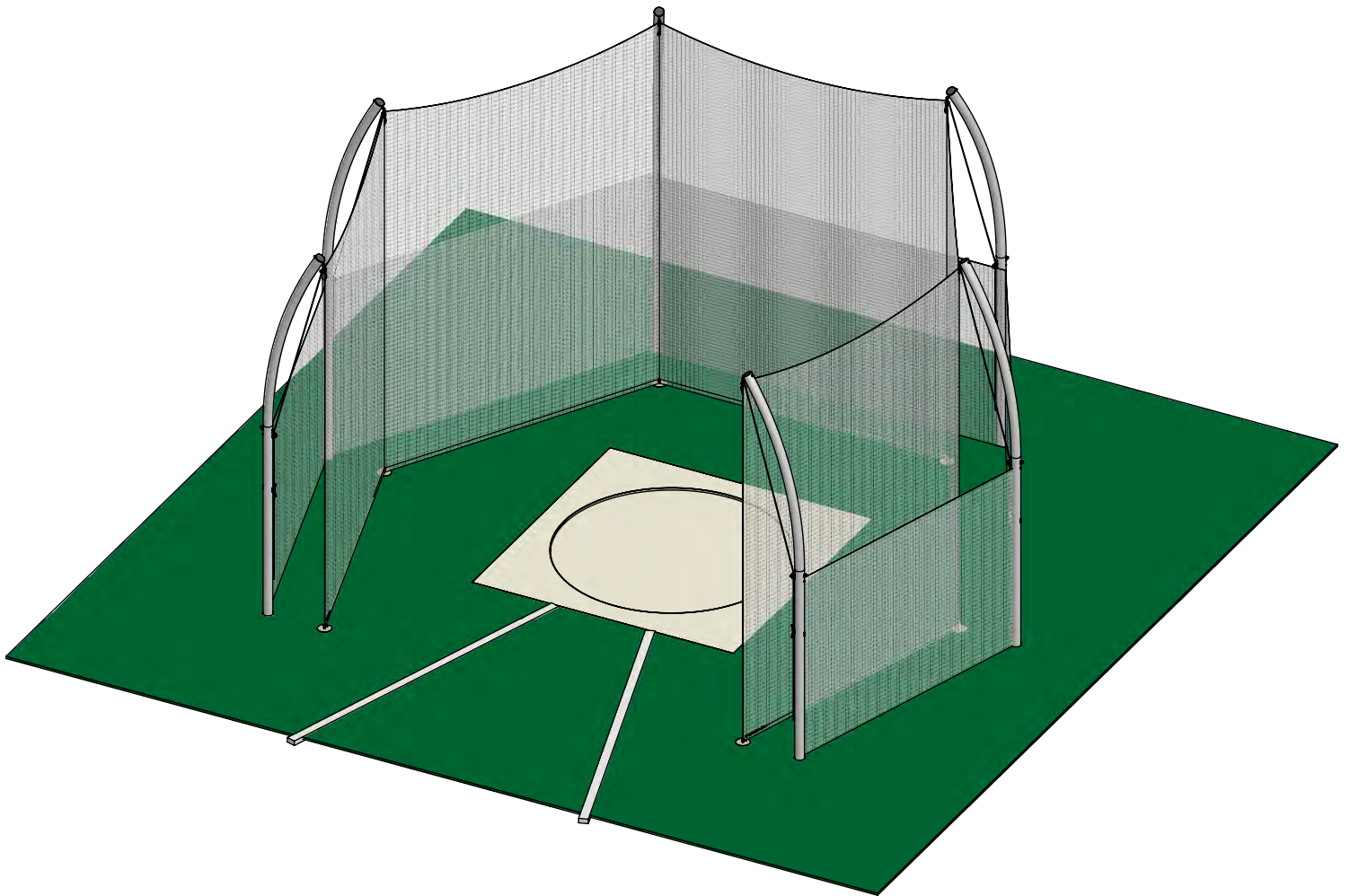

Aluminum Athletic Equipment
1000 Enterprise Drive, Royersford, PA 19468
Toll Free: (800) 523-5471 Fax: (610) 825-2378
www.AAEsports.com

HSDC High School Discus Cage Ground Sleeve Placements

F

F

E

E

D

D

C

C

B

B

A

A

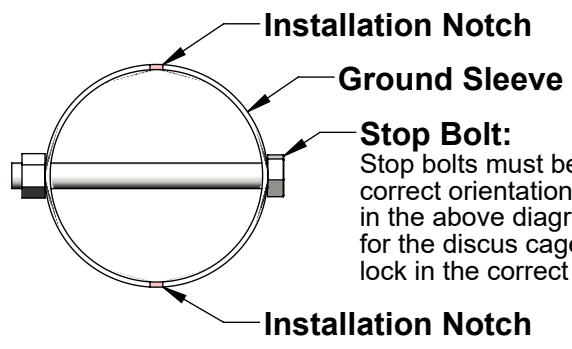
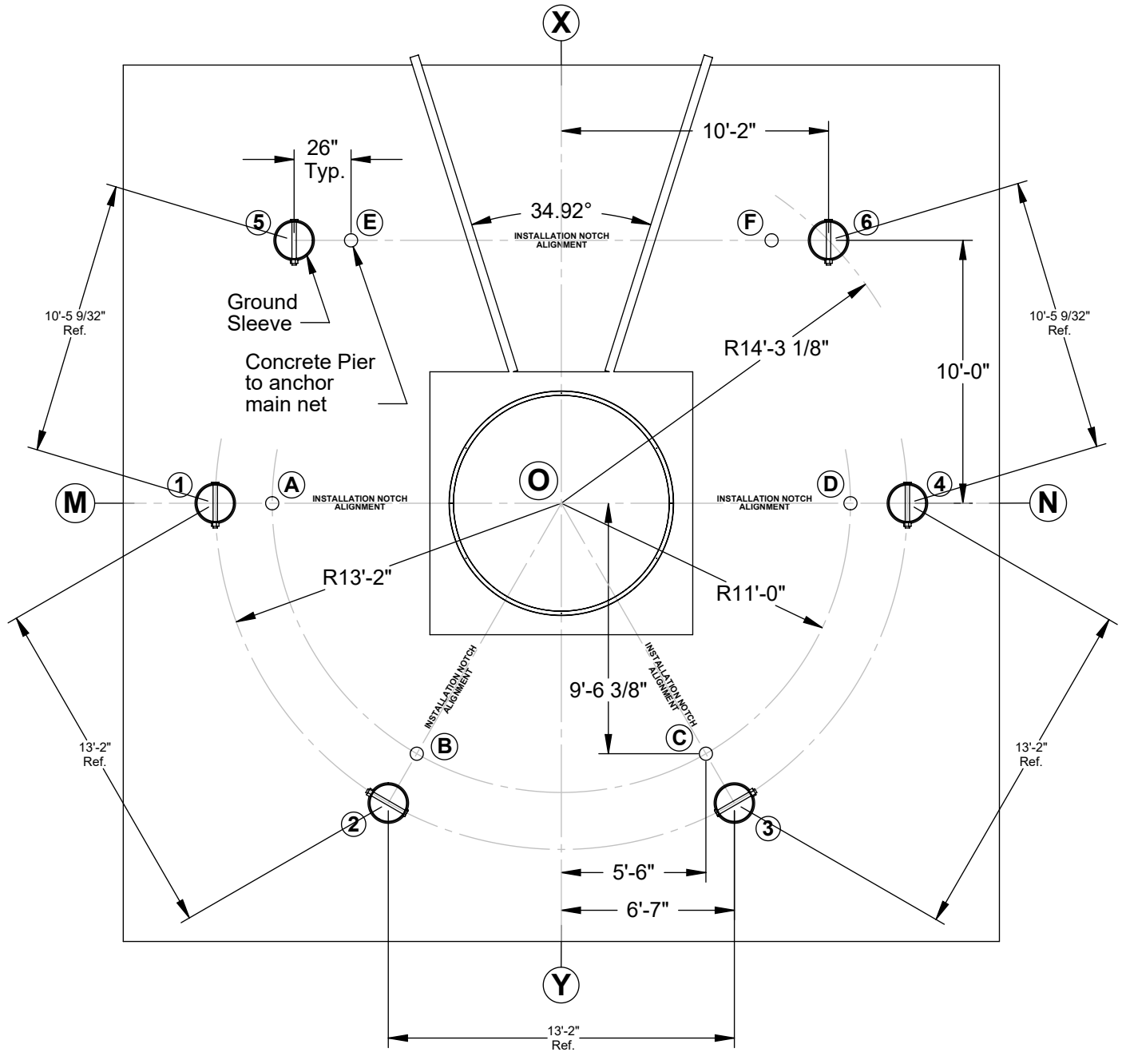

Aluminum Athletic Equipment
1000 Enterprise Drive, Royersford, PA 19468
Toll Free: (800) 523-5471 Fax: (610) 825-2378
www.AAEsports.com

DESCRIPTION: HSDC - Ground Sleeve Layout		
NOTE: High School Discus Cage		
MODEL: HSDC	CATEGORY: CUSTOMER	DATE: 08/09/10
DWN. BY: TAD	CAD FILE: HSDC Packet	DWG. NO. HSDC-C-001

HSDC High School Discus Cage Plan View Layout

F

F

E

E

D

D

C

C

B

B

A

A

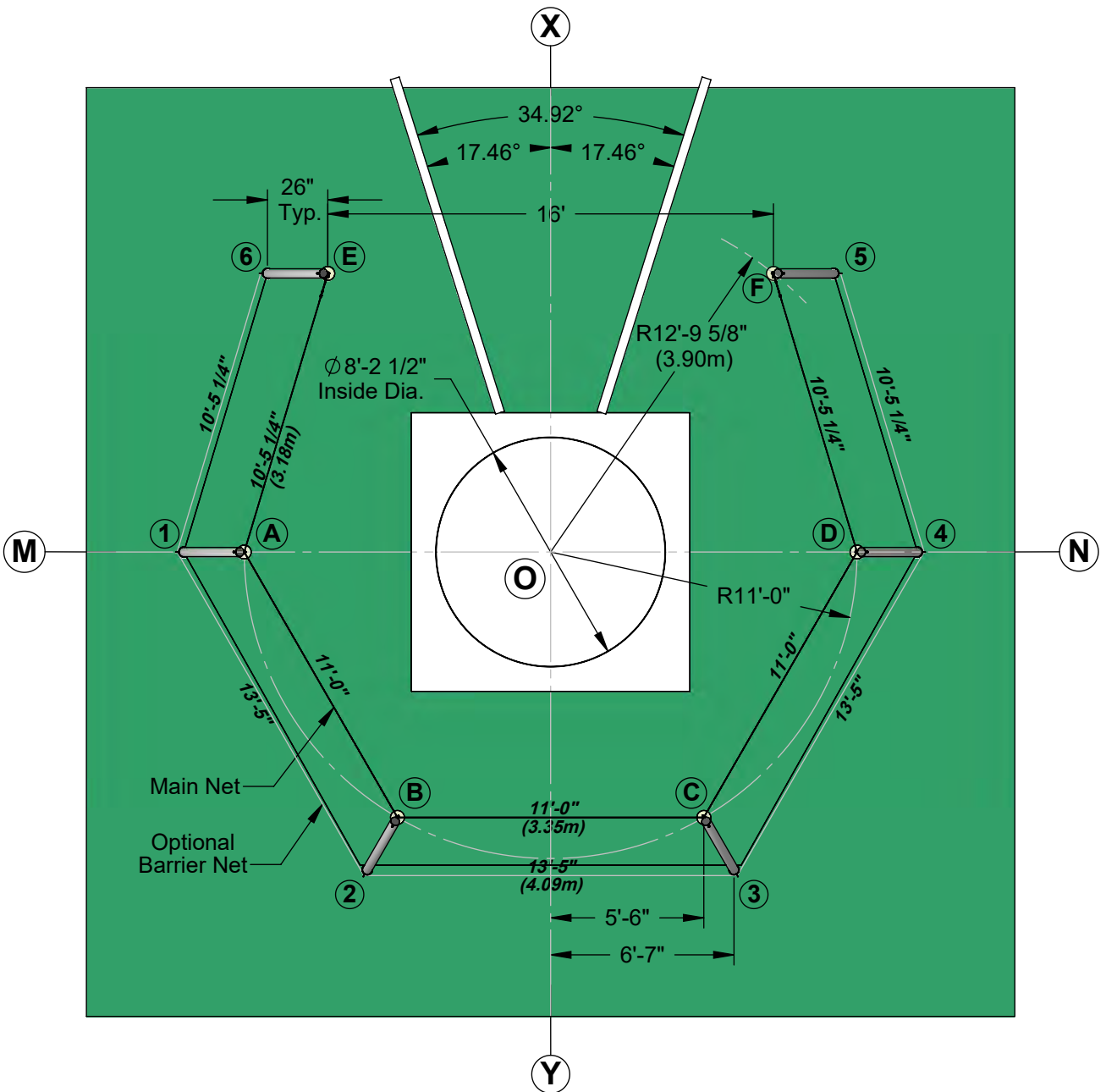

Meets & Exceeds All NFHS Rules & Specifications

Main Net Size = 14'-0" High x 54'-0" Perimeter
 Optional Barrier Net Size = 8'-0" High x 61'-2" Perimeter



Aluminum Athletic Equipment
 1000 Enterprise Drive, Royersford, PA 19468
 Toll Free: (800) 523-5471 Fax: (610) 825-2378
www.AAEsports.com

DESCRIPTION:		
HSDC - Plan View Layout		
NOTE:		
High School Discus Cage		
MODEL:	CATEGORY:	DATE:
HSDC	CUSTOMER	08/09/10
DWN. BY:	CAD FILE:	DWG. NO.:
TAD	HSDC Packet	HSDC-C-002

HSDC High School Discus Cage Installation/Upright Specifications

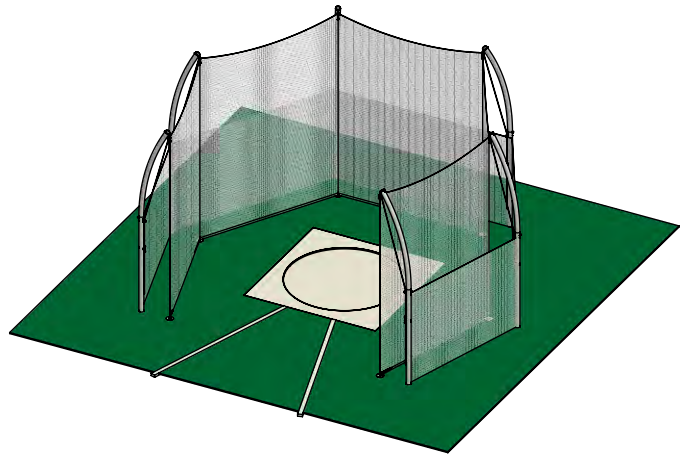
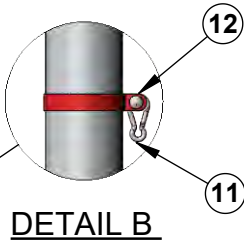
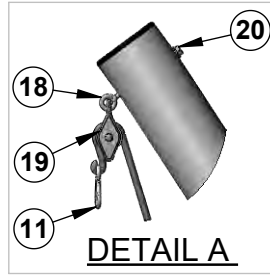
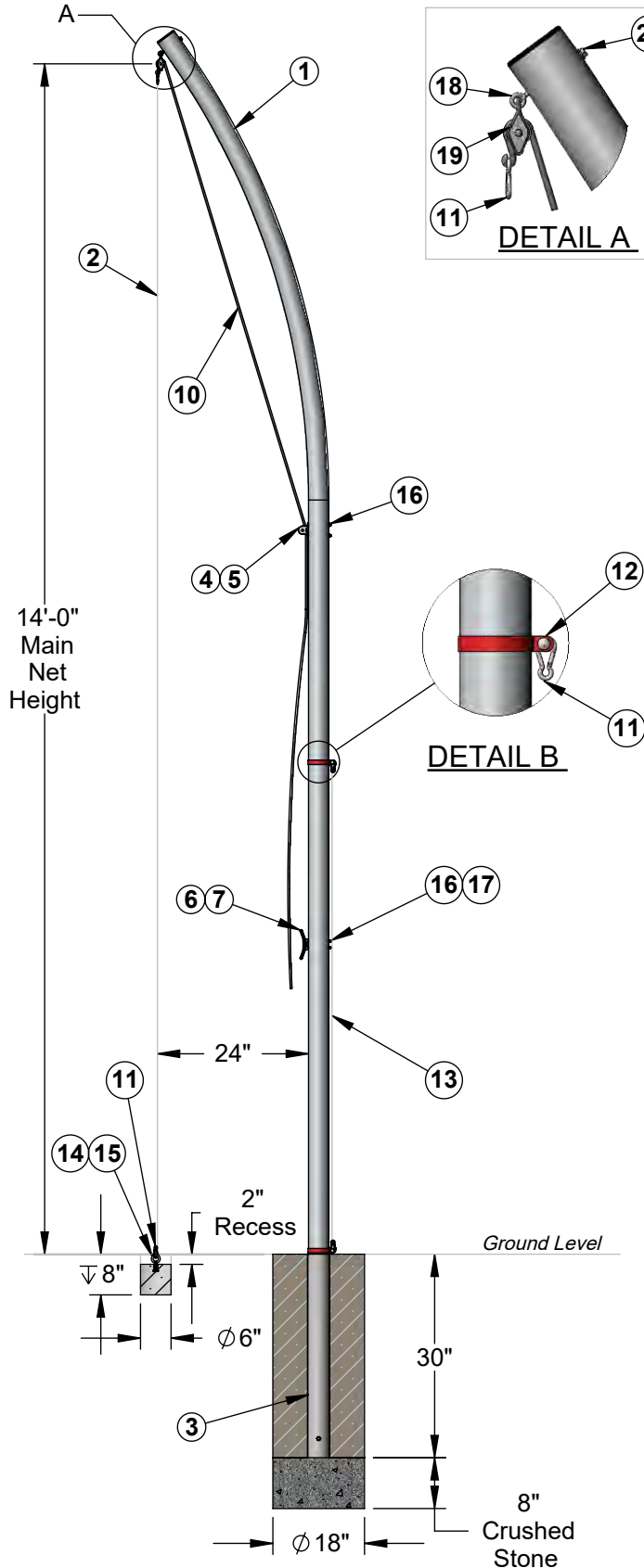

HSDC Ground Sleeve

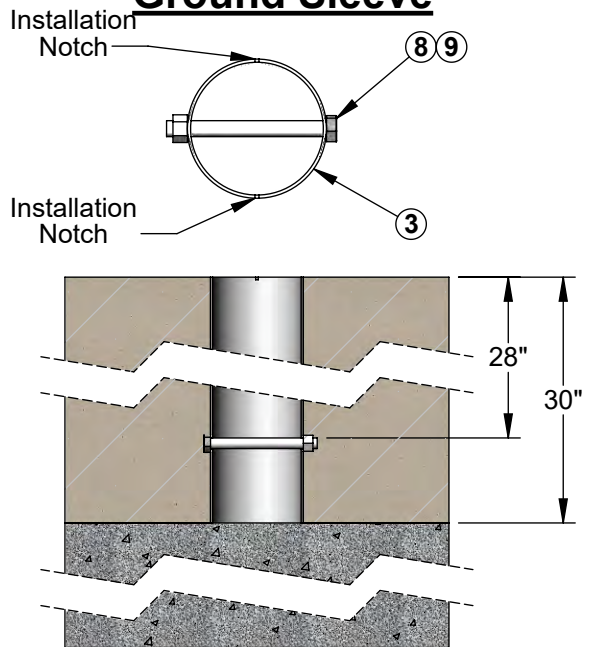

HSDC Specifications

Post (Aluminum):

- Ø4" x .125" wall aluminum tube with 24" Offset (Mill Aluminum 6061T6)
- Weight = 32lbs./ea.
- All Hardware is RUSTPROOF

Netting:

- Net: #AAE N361-#36, 1-3/4" sq. knotted Nylon, DBB, length to vary, 1/4" MFP Rope Border, UV protected and 1/4" cable hog tied to top of net



Aluminum Athletic Equipment
1000 Enterprise Drive, Royersford, PA 19468
Toll Free: (800) 523-5471 Fax: (610) 825-2378
www.AAEsports.com

DESCRIPTION: HSDC - Installation/Upright Specifications		
NOTE: High School Discus Cage		
MODEL: HSDC	CATEGORY: CUSTOMER	DATE: 08/09/10
DWN. BY: TAD	CAD FILE: HSDC Packet	DWG. NO. HSDC-C-003

6

5

4

3

2

1

HSDC High School Discus Cage Concrete Pad Layout

F

F

E

E

D

D

C

C

B

B

A

A

(X)

29'-6 61/64"

22'-6 25/32"

(F)

1'-6"

12'-2 29/64"

24'-4 53/64"

(M)

(1)

(6)

(A)

(O)

(D)

(4)

(N)

1'-6"

14'-8 5/32"

14'-10 25/32"

(Y)

"Square" Concrete Pad

"Hexagon" Concrete Pad

Note: When pouring pad insure that cut lines **DO NOT** cross into throwing circle.

Meets & Exceeds All NFHS Rules & Specifications

"Hexagon" Concrete Pad: 293.75 cubic feet
 "Square" Concrete Pad: 360.904 cubic feet
 Concrete per Footing: 16.6394 cubic feet

Note: Calculations for Concrete Pads made using a depth of 6"



Aluminum Athletic Equipment
 1000 Enterprise Drive, Royersford, PA 19468
 Toll Free: (800) 523-5471 Fax: (610) 825-2378
 www.AAEsports.com

DESCRIPTION:		
HSDC - Concrete Pad Layout		
NOTE: High School Discus Cage		
MODEL:	CATEGORY:	DATE:
HSDC	CUSTOMER	06/15/2018
DWN. BY:	CAD FILE:	DWG. NO.:
TAD	HSDC Packet	HSDC-C-004

4

3

2

1

HSDC High School Discus Cage Tension Cable Detail

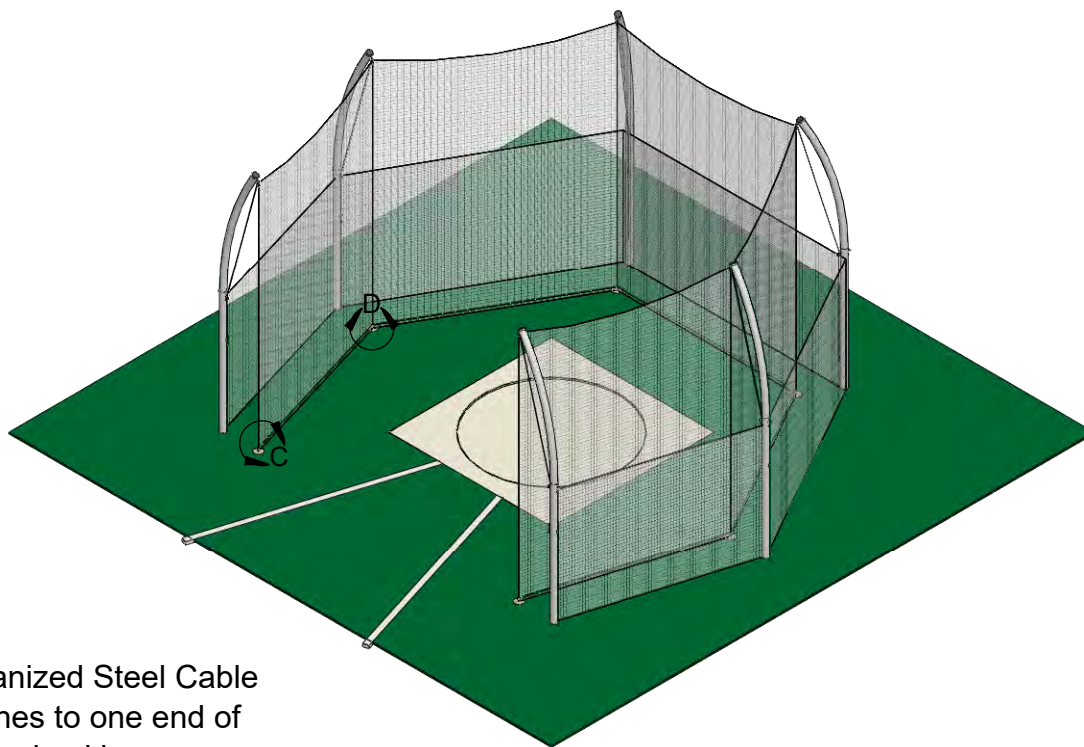

Galvanized Steel Cable attaches to one end of the turnbuckle.

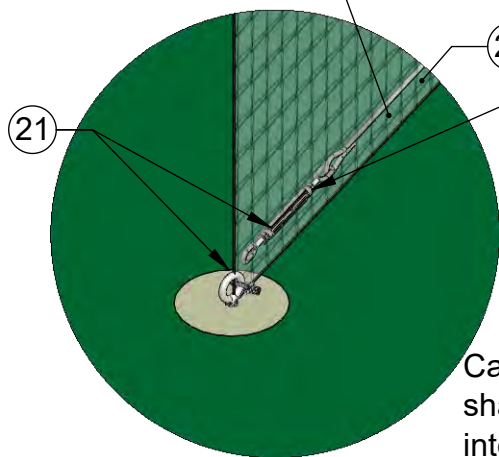

DETAIL C
SCALE 1 : 10

Galvanized Turnbuckle Tensioner attaches to one end.

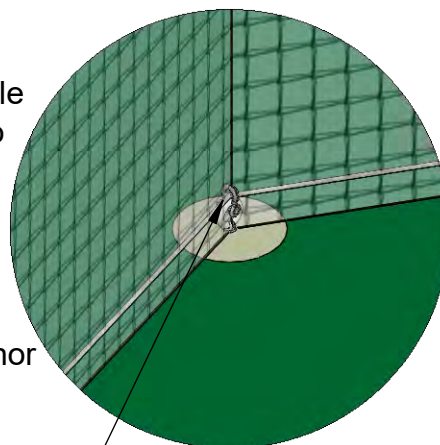

DETAIL D
SCALE 1 : 10

Cable runs through the anchor shackle attached to the intermediate eyebolts and attaches to the opposite end eyebolt via a shackle

Meets & Exceeds All NFHS Rules & Specifications



Aluminum Athletic Equipment
1000 Enterprise Drive, Royersford, PA 19468
Toll Free: (800) 523-5471 Fax: (610) 825-2378
www.AAEsports.com

DESCRIPTION:		
HSDC - Tension Cable Detail		
NOTE:		
High School Discus Cage		
MODEL:	CATEGORY:	DATE:
HSDC	CUSTOMER	06/15/2018
DWN. BY:	CAD FILE:	DWG. NO.:
TAD	HSDC Packet	HSDC-C-005

**HSDC
HIGH SCHOOL DISCUS CAGE
PARTS LIST**

Pt#	Item	Description	Qty.
1	Upright	4.00"o.d. x .125 x 17'6" aluminum tube, 24" arc offset, 6061T6	6
2	Main Net	1-3/4" square x 14' high x 54' long N361-#36 knotted nylon net, breaking strength 381 lbf (1.70kN), B-treated	1
3	Ground Sleeve	4.35" o.d. x .100 x 30" 6061T6 aluminum tube	6
4	Pulley	#18-1 deck block galvanized steel pulley	6
5	Pulley bolt	1/4"- 20 x 4-1/2" hex bolt, 316 stainless steel	12
6	Cleat	6" galvanized steel cleat	6
7	Cleat bolt	1/4"- 20 x 5-1/2" hex bolt, 316 stainless steel	12
8	Stopbolt	1/2"- 13 x 5" steel hex bolt, zinc plated	6
9	Stopbolt Nut	1/2"- 13 steel hex nut, zinc plated	6
10	Hoisting Rope	5/16" polypropylene black braided rope w/ snap - 24' long	6
11	Pear Clip	Pear Clip, 1/4"thick snap, 316 stainless steel (*two extra per upright for barrier net)	12 (*24)
*12	Post Collar	4" I.D. Post Collar with stainless steel hardware	*12
*13	Barrier Net	1-3/4" sq. x 7' high x 61' long N361 knotted nylon net, breaking strength 381 lbf (1.70kN), B-treated (optional)	*1
14	Eyebolt	3/8"-16 x 2-1/2" steel eyebolt, 316 stainless steel	6
15	Concrete Anchor	3/8"-16 tampin insert, P25T	6
16	Nut	1/4"-20 steel nylon lock nut, 316 stainless steel	24
17	Nut	1/4"-20 steel acorn nut, 316 stainless steel	12
18	Eyebolt	5/16"-18 x 6" steel eyebolt, 316 stainless steel	6
19	Swivel Pulley	#3-5 fast eye, galvanized steel, swivel pulley	6
20	Nut	5/16"-18 steel nylon lock nut, 316 stainless steel	6

*** OPTIONAL ITEMS FOR BARRIER NET**

FOR TECHNICAL ASSISTANCE, CALL 1-800-523-5471

K:\AAE Data\PDF Files\Product Instructions & Parts Lists\Track & Field\HSDC\HSDC Parts List.doc
Copyright © 2010 Aluminum Athletic Equipment Co.

**HSDC
HIGH SCHOOL DISCUS CAGE
LAYOUT AND INSTALLATION INSTRUCTIONS**

LAYOUT - (Reference Drawing No. HSDC-C-001 for details)

- Step No. 1 Using masonry string, establish perpendicular lines "MN" and "XY", which intersect at point "O", the center of the discus circle.
- Step No. 2 With point "O" as the center, draw a semi-circle with a radius of 13'-2" (4.01m).
- Step No. 3 Establish lines 6'-7" away, and parallel to, line "XY" on both sides. Locate points "2" & "3" by their intersection with the scribed radius.
- Step No. 4 Establish points "1" & "4", which are 13'-2" (4.01m) from point "O" on line "MN". (Points "1" & "4" should be 13'-2" from points "2" & "3" respectively.)
- Step No. 5 Establish a line 10'-0" (3.18m) away, and parallel to, line "MN". Measure 10'-2" (3.05m) from each side of line "XY" on this line to locate points "5" & "6". (Points "5" & "6" should be 10'-5" from points "1" & "4", respectively.)

NOTE: Points "1" thru "6" are the location of the Center of the ground sleeves to be installed.

- Step No. 6 Extend parallel, perpendicular, and radial lines **26"** from points "1" thru "6" to locate points "A" thru "F". (Note: "A-1", "B-2", "C-3", and "D-4" all point to the center of the circle. -- "E-5", and "F-6" run parallel with line "MN", and perpendicular to "XY".) See Drawing No. HSDC-C-001 for details.

NOTE: Points "A" thru "F" are the location of the Center of the concrete piers that will anchor the bottom of the main net.

INSTALLATION

- Step No. 1
Placing Ground
Sleeves Drill or dig 15" - 18" diameter holes a minimum of 38" deep (**Consult local building codes for concrete depth and drainage requirements.**) at points "1" thru "6". Fill the bottom of each hole with approximately 8" of crushed stone, so the depth from ground level to the top of the stone is 30". Insert the upright ground sleeves (Item No. 3) at points "1" thru "6" ("bolt side" down). Make sure the ground sleeves are flush with the ground, centered, leveled (individually, as well as with each other), and plumb. Also, rotate the ground sleeves so that the two (2) grooves (Installation notches) on top of the ground sleeve are aligned correctly - See "Installation Notch Alignment" on Drawing. No. HSDC-C-001 for

HSDC HIGH SCHOOL DISCUS CAGE LAYOUT AND INSTALLATION INSTRUCTIONS

details. A mason's string or straight edge may be used to aid in the aligning process.

NOTE: It is extremely important that the Installation Notches on top of the ground sleeve are in proper alignment, so the key slot in the main upright will lock the upright into its proper position when set into the ground sleeve.

Step No. 2
Setting Ground
Sleeves

When all the ground sleeves are in the proper position and alignment, the concrete can be poured. **(Be sure not to get any concrete inside the ground sleeves!)** As the concrete cures, constantly check to see that the ground sleeves are flush with the ground, centered, plumb, and in the correct alignment.

Step No. 3
Drilling & Pouring
concrete piers

Drill or dig 5" - 6" diameter holes 10" deep (Consult local building codes for concrete depth and drainage requirements.) at points "A" thru "F". Fill void with concrete to a level 2" below ground level. While the concrete is still in a semi-pliable state, place the tampin insert (Item No. 15) in the center of the pier so that the top of the insert is flush with the top level of the concrete. **(DO NOT get concrete inside the tampin insert!)** When concrete has hardened, thread 3/8"-16 eyebolt w/ attached Pear Clip (Item Nos. 11 & 14) into inserts.

Step No. 4
Upright Assembly

**See Drawing No.
HSDC-C-003**

Attach swivel pulley, w/ attached eyebolt, (Item Nos. 18 & 19) to the top hole of the upright using a 5/16"-18 nylon lock nut (Item No. 20). (If there are 2 holes present at the top of the upright, mount the pulley and eyebolt through the top hole.) Attach a fixed pulley (Item No. 4) through the middle set of holes using 1/4"-20 x 4-1/2" hex bolts (Item No. 5) and 1/4"-20 nylon lock nuts (Item No. 16). Attach one cleat (Item No. 6) through the lower set of holes using 1/4"-20 x 5-1/2" hex bolts (Item No. 7) and 1/4"-20 nylon lock nuts (Item No. 16). Cap threads with 1/4" -20 acorn nuts (Item No. 17). Thread hoisting rope (Item No. 10) with attached pear clip (Item No. 11) through top pulley, middle pulley, and secure to cleat. After concrete cures, slowly lower assembled upright into ground sleeve. Repeat procedures to assemble other five uprights.

Step No. 5
Hanging Main Net

**See Drawing No.
HSDC-C-002**

Lower hoisting rope w/ attached pear clip (Item Nos. 10 & 11) to about 4 ft. above ground level. (Keep end of rope secured to cleat so you don't lose the rope!) Layout the main net and attach the swivel snap on the end of the hoisting rope to the framing rope on the top border of the net. (It is best to find the top center of the net

**HSDC
HIGH SCHOOL DISCUS CAGE
LAYOUT AND INSTALLATION INSTRUCTIONS**

first, attach the pear clips at poles #2 & 3 at the appropriate distance, and then work your way out to both ends.) After the entire net is snapped into position, raise the net all the way by the hoisting rope and secure the end of the rope firmly and professionally to the cleat. (Consult former Navy personnel or Scout for proper method.)

*Barrier Net
(Optional)

Attach post collars with attached Pear Clips (Item Nos. 11 & 12) to each upright with the pear clip facing the rear of the upright, one should be position at the bottom and one should be positioned 7'-0" up the post. Layout barrier net, and attach frame of net to pear clips. (Any excess net may be wrapped around and laced to the upright.)

FOR TECHNICAL ASSISTANCE, CALL 1-800-523-5471

K:\AAE Data\PDF Files\Z-Product Instructions & Parts Lists\Track & Field\HSDC\HSDC-34.92 Assembly Instructions.doc
Copyright © 2000 Aluminum Athletic Equipment Co.