

**Model No.: HSG-NCAA/8**  
**8' Hinged Offset College Football Goal**

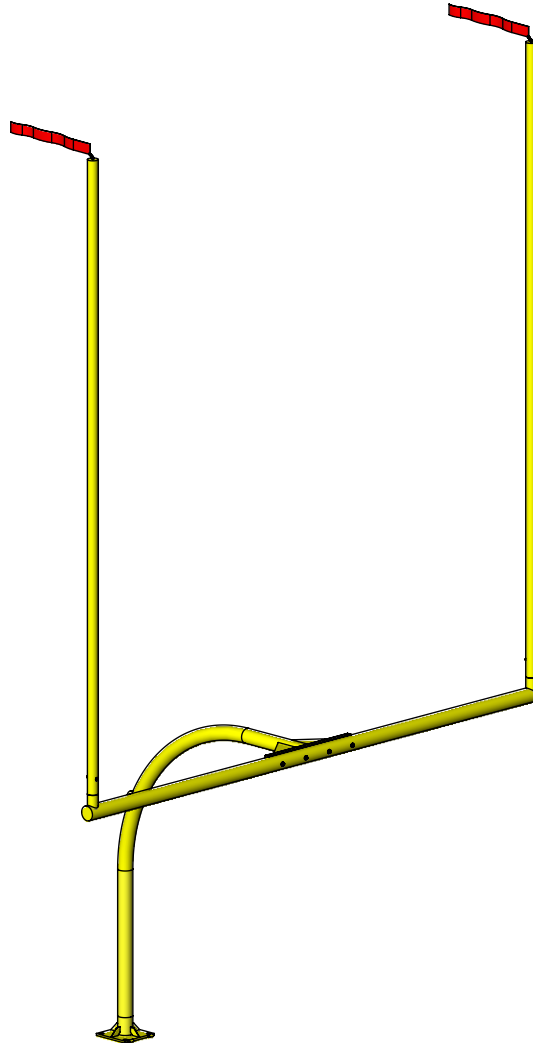

**Aluminum Athletic Equipment**  
1000 Enterprise Drive, Royersford, PA 19468  
Toll Free: (800) 523-5471 Fax: (610) 825-2378  
[www.AAEsports.com](http://www.AAEsports.com)

# HSG-NCAA/8 - 8' Hinged Offset Football Goal

## Specifications

Red Nylon Streamers  
4" wd. x 42" lg.  
(Included)

Ø 4" x .125" wall  
Aluminum Uprights  
(6061T6)

Ø 5-9/16" x .250" wall  
Aluminum Crossbar  
(6061T6)

Galvanized Steel  
Welded C-Channel  
w/ Gusset

Galvanized Steel  
Offset Center Post  
(Ø 5-9/16" x .1875" wall)

R5'-0"

8'- 0"  
Offset

**SIDE VIEW**

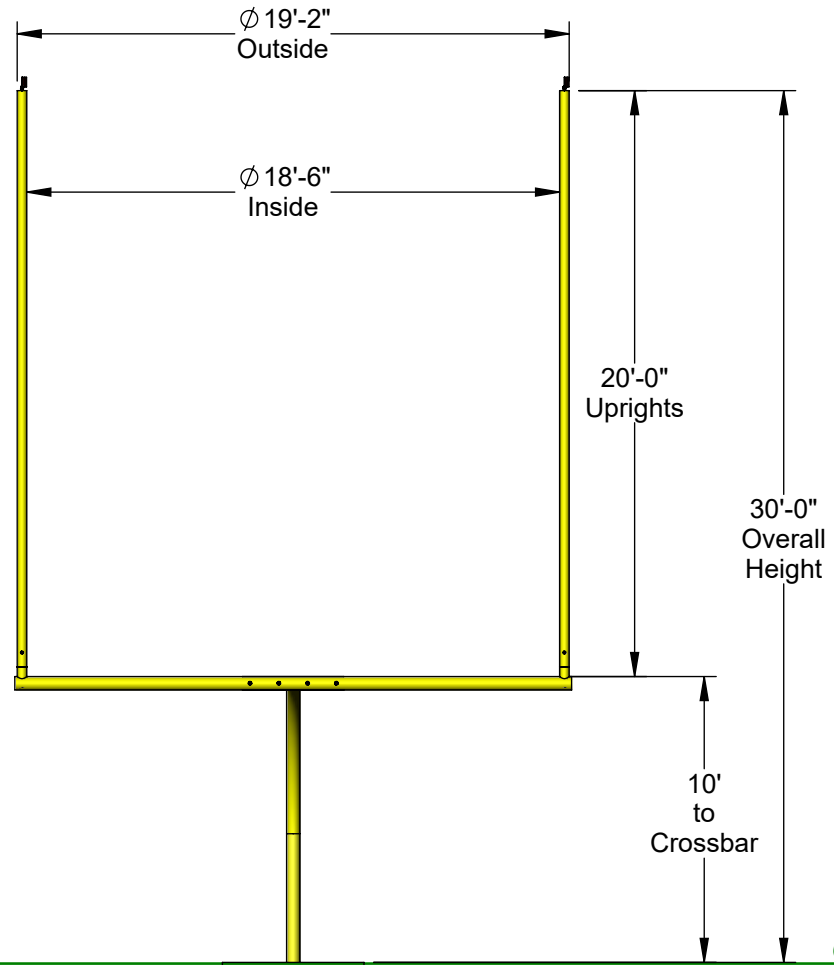

**FRONT VIEW**



**Aluminum Athletic Equipment**  
1000 Enterprise Drive, Royersford, PA 19468  
Toll Free: (800) 523-5471 Fax: (610) 825-2378  
www.AAEsports.com

DESCRIPTION: <b>HSG-NCAA/8, 8' Hinged Offset Football Goal</b>		
NOTE: Specifications		
MODEL: HSG-NCAA/8	CATEGORY: <b>CUSTOMER</b>	DATE: 5/24/2021
DWN. BY: CED	CAD FILE: HSG-NCAA_8, 8' Offset Specifications	DWG. NO. HSG-NCAA/8-C-001

*\* The Entire Goal is Powder-coated White or Yellow Customer's Choice.*



# HSG-NCAA/8 - 8' Offset Football Goal

## Footing & Weight Specifications

**HSG-NCAA**  
**Entire Football Goal**  
**Weighs: 565 lbs./ea.**  
**Total: 1130 lbs./pair**

**(2) Uprights = 40 lbs./ea.**

**(1) Crossbar = 110 lbs.**

**(1) Gooseneck = 255 lbs.**

**(1) Foundation = 120 lbs.**

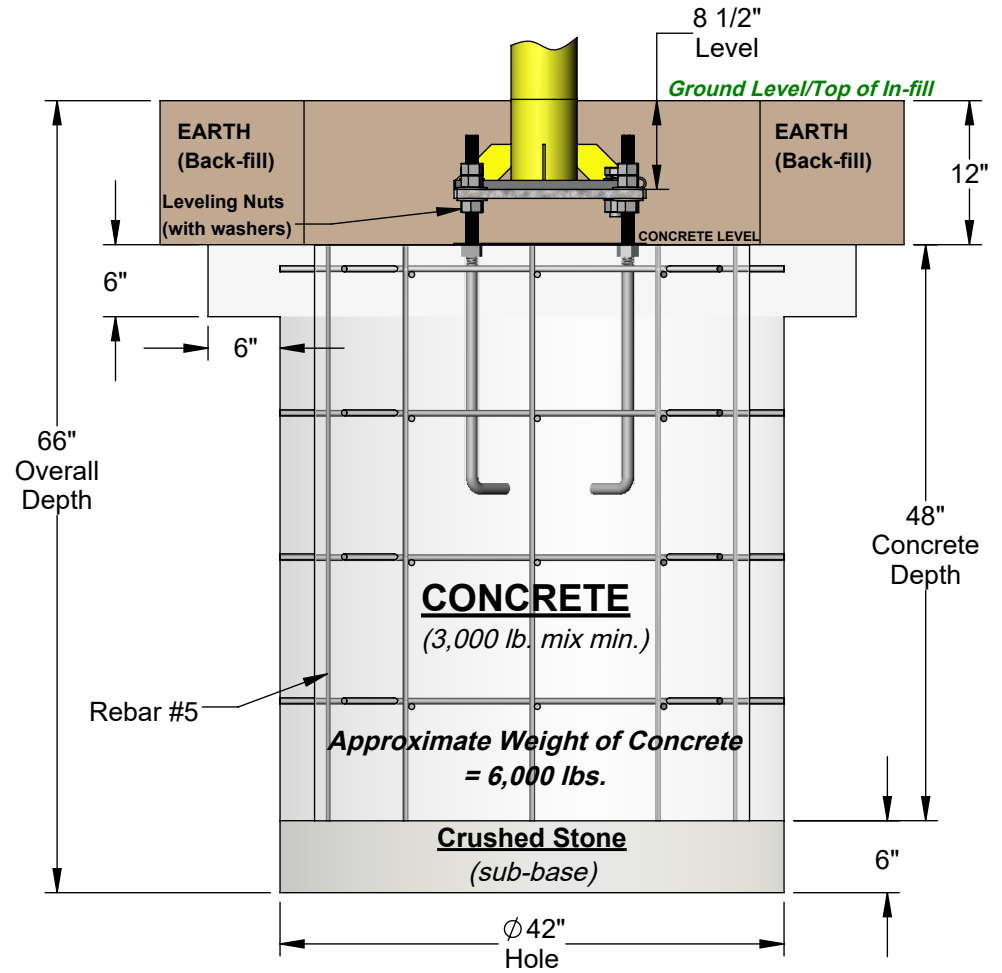
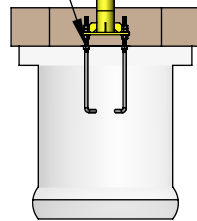

**Aluminum Athletic Equipment**  
 1000 Enterprise Drive, Royersford, PA 19468  
 Toll Free: (800) 523-5471 Fax: (610) 825-2378  
 www.AAEsports.com

DESCRIPTION:		
<b>HSG-NCAA/8, 8' Hinged Offset Football Goal</b>		
NOTE: Footing and Weight Specifications		
MODEL:	CATEGORY:	DATE:
HSG-NCAA/8	<b>CUSTOMER</b>	05/18/2021
DWN. BY:	CAD FILE:	DWG. NO.:
CED	HSG-NCAA_8, 8' Offset Specifications	HSG-NCAA/8-C-003

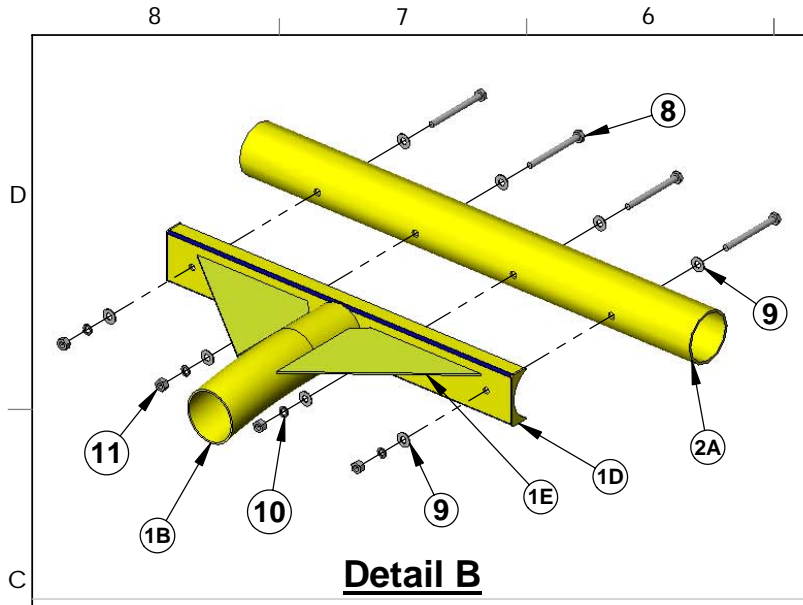

**Detail B**

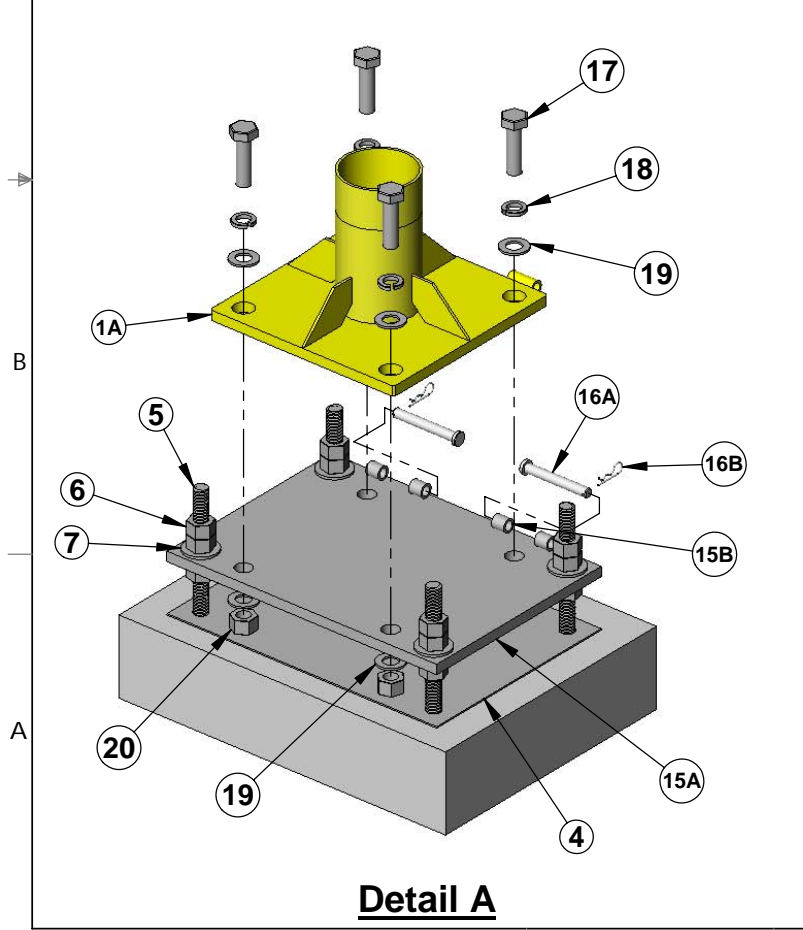

**Detail A**

# HSG-NCAA/8 (Hinged) Assembly

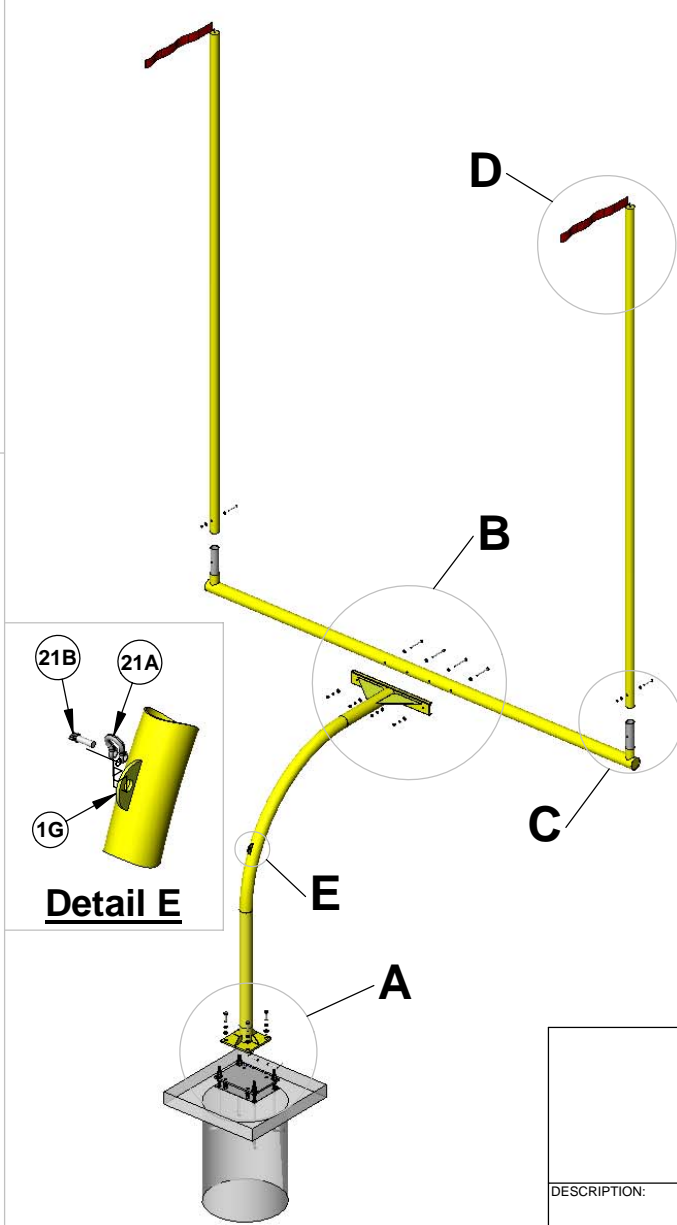

**Detail E**

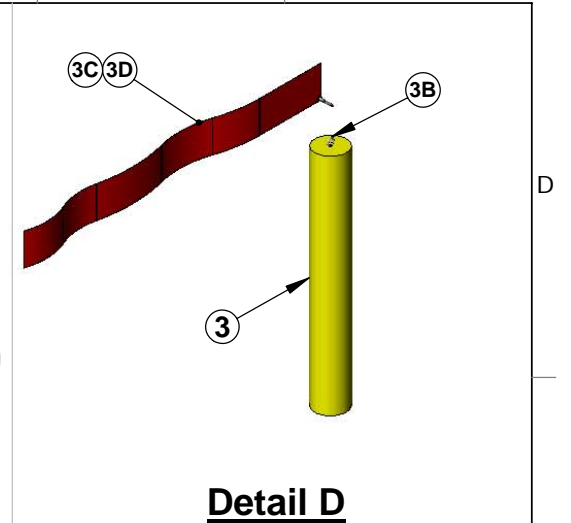

**Detail D**

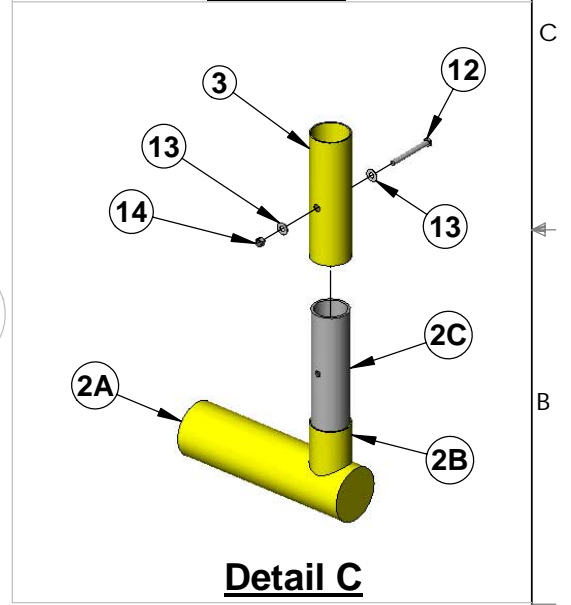

**Detail C**

 Aluminum Athletic Equipment 1000 Enterprise Drive, Royersford, PA 19468 Toll Free: (800) 523-5471 Phone: (610) 825-6565 <a href="http://www.aaesports.com">www.aaesports.com</a>		
DESCRIPTION:		
<b>HSG-NCAA/8 - Assembly</b>		
NOTE:		
Parts List Callout		
MODEL:	CATEGORY:	DATE:
HSG-NCAA/8	CUSTOMER	6/1/05
DWN. BY:	CAD FILE:	DWG. NO.:
TAD	HSG-NCAA/8 - Assembly	HSG-NCAA/8-C-004

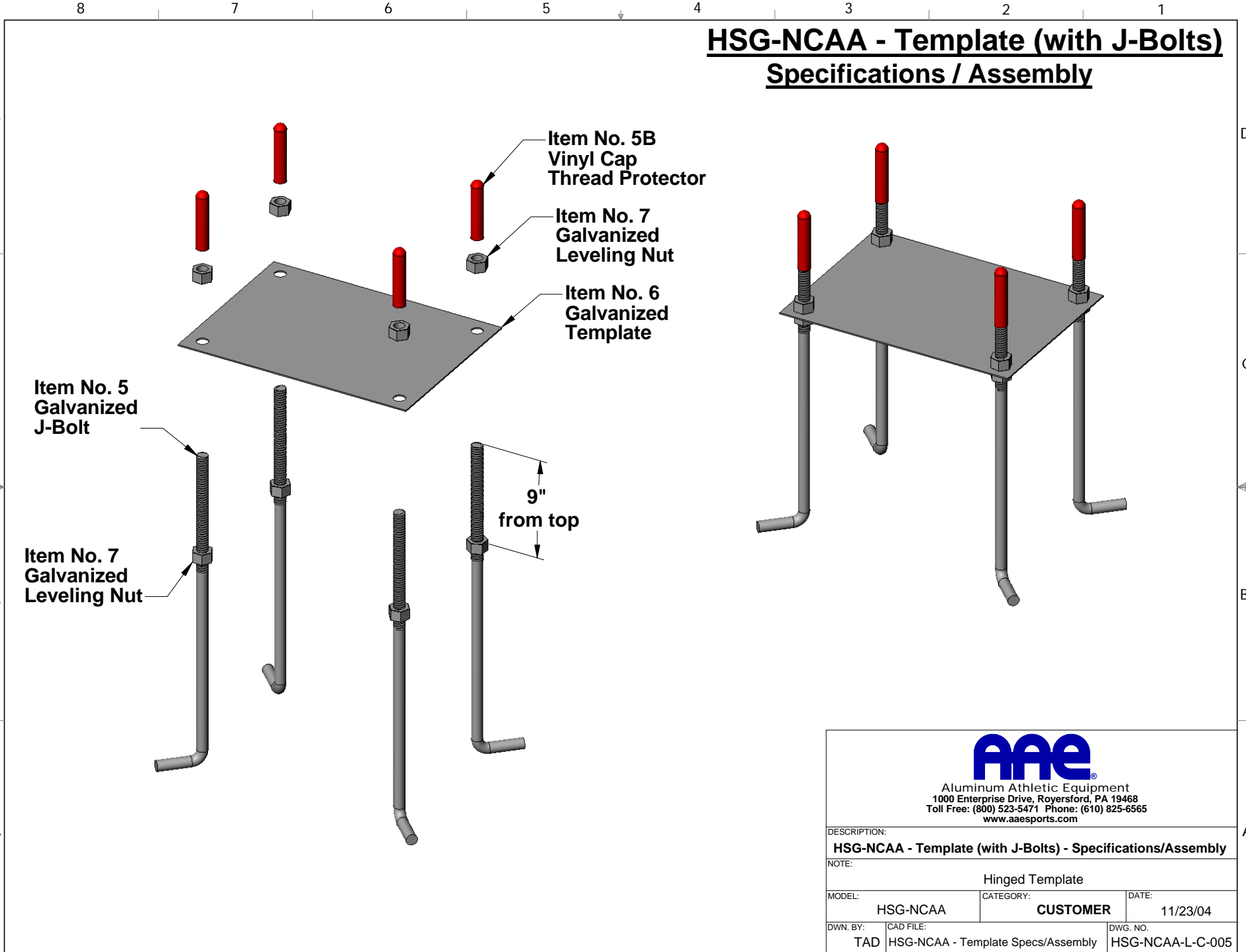

# HSG-NCAA - Template (with J-Bolts)

## Specifications / Assembly

Item No. 5B  
Vinyl Cap  
Thread Protector

Item No. 7  
Galvanized  
Leveling Nut

Item No. 6  
Galvanized  
Template

Item No. 5  
Galvanized  
J-Bolt

Item No. 7  
Galvanized  
Leveling Nut

9"  
from top



Aluminum Athletic Equipment  
1000 Enterprise Drive, Royersford, PA 19468  
Toll Free: (800) 523-5471 Phone: (610) 825-6565  
[www.aesports.com](http://www.aesports.com)

DESCRIPTION: <b>HSG-NCAA - Template (with J-Bolts) - Specifications/Assembly</b>		
NOTE: Hinged Template		
MODEL: HSG-NCAA	CATEGORY: <b>CUSTOMER</b>	DATE: 11/23/04
DWN. BY: TAD	CAD FILE: HSG-NCAA - Template Specs/Assembly	DWG. NO. HSG-NCAA-L-C-005

**HSG-HS / HSG-NCAA**  
**HINGED 8' OFFSET FOOTBALL GOAL**  
**ASSEMBLY & INSTALLATION**  
(W/ LEVELING NUTS)

---

**TEMPLATE ASSEMBLY:** (See Dwg. No. HSG-8-L-C-005)

1. Thread 1"-8 galvanized steel hex nuts (Item no. 7) onto the J-bolts (Item No. 5). Position the first 4 nuts so that the top of each nut is 9" down from the top of the J-bolt.
2. Insert each assembled J-bolt through the holes in the template (Item No. 6) and "tighten" with the remaining 1"-8 hex nuts. Place the vinyl caps (Item No. 5B) over the top of the J-bolts to protect the threads until goal assembly.
3. Once assembled, all the J-bolts should point out from the template (as pictured).

**TEMPLATE INSTALLATION:** (See Dwg. No. HSG-8-L-C-002)

1. Locate the centerline of the football field and the end zone lines. Make sure that it is the end zone lines that are located and not the goal line.
2. Locate a point 8'-2" back from the front edge of the end line, on the centerline of the football field. (The "front edge" denoting the edge of the 4" painted line closest to the end zone - See Dwg. No. HSG-8-L-C-002 for details)
3. Using this point as the center, dig a hole approximately 42" in diameter, and 5'0" - 6'0" deep. (This is the minimum recommended depth - consult local building codes for concrete depth and drainage requirements.)
4. Add 4" - 6" of crushed stone to the bottom of the hole for proper drainage. (Once again - consult local codes.)
5. Use #5 Rebar or something comparable to help reinforce the concrete installation. Typically only used in California to meet earthquake codes.

**SET THE TEMPLATE ASSEMBLY IN PLACE:** (See Dwg. No. HSG-8-L-C-002)

1. Using 2"x4"s, or some other suitable supporting member, suspend the foundation assembly over the excavated hole so that the center of the plate is exactly over the center of the hole (Remember - the center of the hole should be exactly 8'-2" back from the front edge of the end line on the centerline of the football field.) Position the foundation plate assembly so that the top of the foundation plate is exactly 12" below ground level. Use a plumb bob to check that the center of the plate is over the center of the hole.
2. Make sure that the assembly is centered, level and plumb over the hole. The front anchor bolts **MUST** be parallel with the end line. The orientation of these anchor bolts is pertinent to the successful installation of the goal. If these bolts are not parallel to the end line when the concrete is poured, no adjustment can be made

**HSG-HS / HSG-NCAA**  
**HINGED 8' OFFSET FOOTBALL GOAL**  
**ASSEMBLY & INSTALLATION**  
(W/ LEVELING NUTS)

---

later.

**Note:** Refer to Drawing No. HSG-8-L-C-002, and make sure that the dimensions between "the J-Bolts" match that to the dimensions given on drawing. *(13" Horizontally, 19" Vertically, & 23" Diagonally.)*

3. Once all the adjustments have been made, and the foundation assembly is properly supported, the concrete may be poured. If red "vinyl protector caps" (Item No. 5B) are not on the studs already, place them on now to protect the J-bolts while the concrete is being poured. We suggest that a minimum of 3000 lb. concrete mix be used for the foundation.
4. Allow more than ample time (16-18 days) for the concrete to cure before erecting the goal.

**ASSEMBLING THE GOAL:** (See Dwg. No. HSG-8-L-C-004)

1. Cement should be hardened completely before continuing.
2. Refer to Drawing No. HSG-8-L-C-004. When erecting the goal make sure that all pieces correspond properly.
3. Brush the foundation clean of any dust, debris, etc. Remove the "vinyl protector caps" from the J-bolts.
4. Take the 4 nuts (already on J-bolts) on top of the template and run them up to a distance so the top of the leveling plate is approximately 7-1/2" from ground/grade level. Place 1" washers on top of the 4 nuts before goal is assembled. Take the leveling plate (Item No. 15A) and place it on top of the 4 leveling nuts with washers (make sure the hinges are facing the goal line).
5. Once the leveling plate is level, place 1" flat washer, then two 1"-8 hex nuts (Item Nos. 6 & 7) on each J-bolt to secure the plate to the foundation J-bolts.
6. Place the gooseneck (Item No. 1) in front of the concrete foundation. Using at least 3 men, lift and hinge the main standard into place over the leveling plate with hinges. Insert the hinge pins (Item No. 16A) and the cotter pins (Item No. 16B) to secure gooseneck.
7. While the Gooseneck can still be maneuvered, align it as best as possible. Raise it by hand using at least 3 men. Check the height from ground level to the top of the c-channel (it should be 10') make any adjustments using the leveling nuts. Using a torque wrench, tighten all hex nuts to 75-80 foot-pounds apiece. Nuts may be loosened later if final adjustments need to be made. **NOTE: Never** attempt to tighten down the nuts on the baseplate of the goal without first relieving the pressure of the goal against the nut (meaning, push the gooseneck back using at least 3 men to relieve the stress and make it easier to loosen). Trying to tighten the



**HSG-HS / HSG-NCAA**  
**HINGED 8' OFFSET FOOTBALL GOAL**  
**ASSEMBLY & INSTALLATION**  
(W/ LEVELING NUTS)

---

- nut with the weight of the goal pressing on it will damage the threads and cause irreversible damage!
8. Lower Gooseneck back down to ground level.
  9. Place the crossbar (Item No. 2) in front of the gooseneck's c-channel (Item No. 1D). Using 2 men lift the gooseneck enough to align the 4 holes in the c-channel with the 4 holes in the crossbar. You may want to use a block of wood under c-channel to ease assembly. Also to make it easy, you can place the 5/8"-11 x 7" hex bolts with washers (Item Nos. 8 & 9) in through holes on crossbar and use a piece of tape to hold the 4 bolt assemblies in position, then all you need to do is place the loc washers, washers, and nuts (Item Nos. 9,10, & 11) on to secure it to the c-channel. Using a torque wrench, tighten all 4 bolts to 70 foot-pounds apiece.
  10. If red streamers (Item No. 3C & 3D) are not attached to the top of the 4" uprights, do so at this time with the enclosed hardware. Eyebolts are provided at the top of each upright for attachment.
  11. Lift each upright (Item No. 3) into position on the crossbar. Attach upright through aluminum sleeve (Item No. 2C) using 1/2"-13 x 5" hex bolts, flat washers, and hex nuts (Item Nos. 12,13, & 14). Attach hardware so that the heads of the bolts are on the front of the upright and on the inside of the upright. Torque bolts to 60 foot pounds a piece.
  12. Attach the Anchor Shackle (Item No. 21) to the Hoisting Bracket (Item No. 1G) on the arc of the gooseneck. Make sure Anchor Shackle Pin (Item No. 21B) is secure.
  13. Using a heavy duty chain (3000 lbs. min. strength), approximately 12' to 15' long, attach to the anchor shackle. Anchor the chain to the front of a vehicle (ex: Ford F150, Maintenance Gator Cart) with a tow hitch. Slowly raise the goal until the Gooseneck Baseplate (Item No. 1A) is parallel to the Leveling Plate (Item No. 15A).
  14. **NOT AT ANY TIME** should **ANYONE** step in front of the goal when being raised or lowered, until **Step No. 15 is COMPLETED**.
  15. Always be off to the side and never in the direct falling path of the Gooseneck (Item No. 1). Secure Gooseneck Baseplate (Item No. 1A) to the Leveling Plate (Item No. 15A) using 1"-8 x 3-1/2" hex bolts, loc washers, flat washers, and hex nuts (Item Nos. 17,18,19, & 20). Using a torque wrench, tighten all 4 bolts 75 to 80 foot-pounds apiece.
  16. Now the goal is assembled. Any additional adjustments should be made, such as the uprights leaning forward can be fixed by loosening the 4 crossbar bolt assemblies, and using three (3) men and three (3) 10' ladders (one at each upright and one in the center of the crossbar), pull back on uprights until perpendicular (use a 4' level). Once they are perpendicular have the person on the center ladder re-

**HSG-HS / HSG-NCAA**  
**HINGED 8' OFFSET FOOTBALL GOAL**  
**ASSEMBLY & INSTALLATION**  
(W/ LEVELING NUTS)

---

torque the 4 bolts attaching the crossbar to the c-channel. (Once entire goal is erected and all final adjustments have been made, cut & place the vinyl protector caps back on the J-bolts.)

17. Make any other necessary adjustments to make the goal plumb, and square with the end line. The top of the crossbar should be 10'-0" from ground level.
18. Repeat Steps 1-17 to assemble other goal.

**OPERATION AND CARE:**

1. If the goal is to be removed, AAE's synthetic foundation box and covers (FBC-S/HSG) should be used. "Vinyl protector caps" should be placed on the studs whenever possible.
2. All bolts and nuts should be checked and re-torqued each year. It is important the aforementioned torque specifications be followed as over-torquing could possibly snap or destroy bolts or studs. Failure to properly maintain the goal on a regular basis, as with any other large equipment, could lead to serious injury or death.
3. Never attempt to tighten down the nuts on the baseplate of the goal without first relieving the pressure of the goal against the nut. Trying to tighten the nut with the weight of the goal pressing on it will damage the threads and cause irreversible damage!
4. **ALWAYS** wear protective gloves and hardhat when assembling goals!

**HSG-NCAA/8  
HINGED SINGLE 8' OFFSET  
NCAA FOOTBALL GOALS  
PARTS LIST**

Part#	Item	Description	Qty.
1	Gooseneck Assembly	Gooseneck assembly is completely galvanized after the following components are welded then powder-coated white or yellow:	2
1A	Baseplate	15" sq. x 3/4" thick, HRS	***
1B	Gooseneck	5-1/2" o.d. x .188" wall steel tubing	***
1C	Baseplate Rib	4-1/2" x 3" x 1/4" thick HRS	***
1D	C-Channel	5-9/16" x 2-1/8" legs x 1/4" wall, 42" lg., HRS	***
1E	C-Channel Rib	12" x 15" x 1/4" steel reinforcing plate, HRS, w/ welded end cap	***
1F	Hinges	3/4" schedule 80 pipe	***
1G	Hoisting Bracket	3/8" thick half moon welded bracket with 1-1/4" hole	***
1H	Reinforced Rib	1/4" thick welded reinforcement rib	***
2	Crossbar Assembly	Crossbar assembly is completely welded then powder-coated white or yellow:	2
2A	Crossbar	5" Sch. 40 aluminum pipe, 5-9/16" o.d. x .258 wall x 19'-4" lg., 6061T6	***
2B	Outer Sleeve	4" dia. x .125" wall, 6061T6 aluminum tube	***
2C	Sleeve Insert	3-3/4" dia. x .375" wall, 6061T6 aluminum tube	***
3	Upright Assembly	Uprights have a cap at the top welded then powder-coated white or yellow:	4
3A	Upright	4" o.d. x .125 wall x 20' lg., 6061T6 aluminum tube	***
3B	Eyebolt	5/16" eyebolt, stainless steel	***
3C	Streamer	4" x 42" red nylon streamer	***
3D	Clip	Aluminum pear clip	***
4	Foundation Template	16" x 22" x 11 gauge HRS, galvanized	2

**HSG-NCAA/8  
HINGED SINGLE 8' OFFSET  
NCAA FOOTBALL GOALS  
PARTS LIST**

5	J-Bolt	1"-8 x 33" lg. j-bolt, grade 5, galvanized steel	8
5B	Vinyl Cap	1" dia. x 8" lg. red vinyl cap protector	8
6	Nut	1"-8 nut, grade 5, galvanized steel	32
7	Washer	1" doc washer, grade 5, galvanized steel	16
8	Bolt	5/8"-11 x 7" bolt, galvanized steel	8
9	Washer	5/8" washer, galvanized steel	16
10	Loc-washer	5/8" loc-washer, galvanized steel	8
11	Nut	5/8"-11 nut, galvanized steel	8
12	Bolt	1/2"-13 x 5" bolt, galvanized steel	4
13	Washer	1/2" washer, galvanized steel	8
14	Nut	1/2"-13 nut, galvanized steel	4
15	Leveling Plate Assembly	Leveling plate assembly is completely galvanized after the following components are welded:	2
15A	Leveling Plate	16" x 22" x 3/4" thick HRS, with adjustment slots	***
15B	Hinges	3/4" schedule 80 pipe	***
16	Hinge Pin Assembly	Components: (Clevis Pin Clip should always be engaged into Detent Clevis Pin)	4
16A	Detent Clevis Pin	5/8" dia. x 5" long pin, stainless steel	***
16B	Clevis Pin Clip	1/8" dia. clip, stainless steel	***
17	Bolt	1"-8 x 3-1/2" bolt, grade 5, galvanized steel	8
18	Loc-washer	1" loc-washer, galvanized steel	8
19	Washer	1" washer, galvanized steel	16
20	Nut	1"-8 nut, grade 5, galvanized steel	8

**HSG-NCAA/8  
HINGED SINGLE 8' OFFSET  
NCAA FOOTBALL GOALS  
PARTS LIST**

21	Anchor Shackle Assembly	Components: (Shackle pin should always be engaged into the Shackle)	2
21A	Shackle	Anchor shackle with 1-1/4" opening, galvanized	***
21B	Shackle Pin	5/8"-11 shackle pin, galvanized	***

\*\*\* Items are included in the assembled part.

**FOR TECHNICAL ASSISTANCE, CALL 1-800-523-5471**