

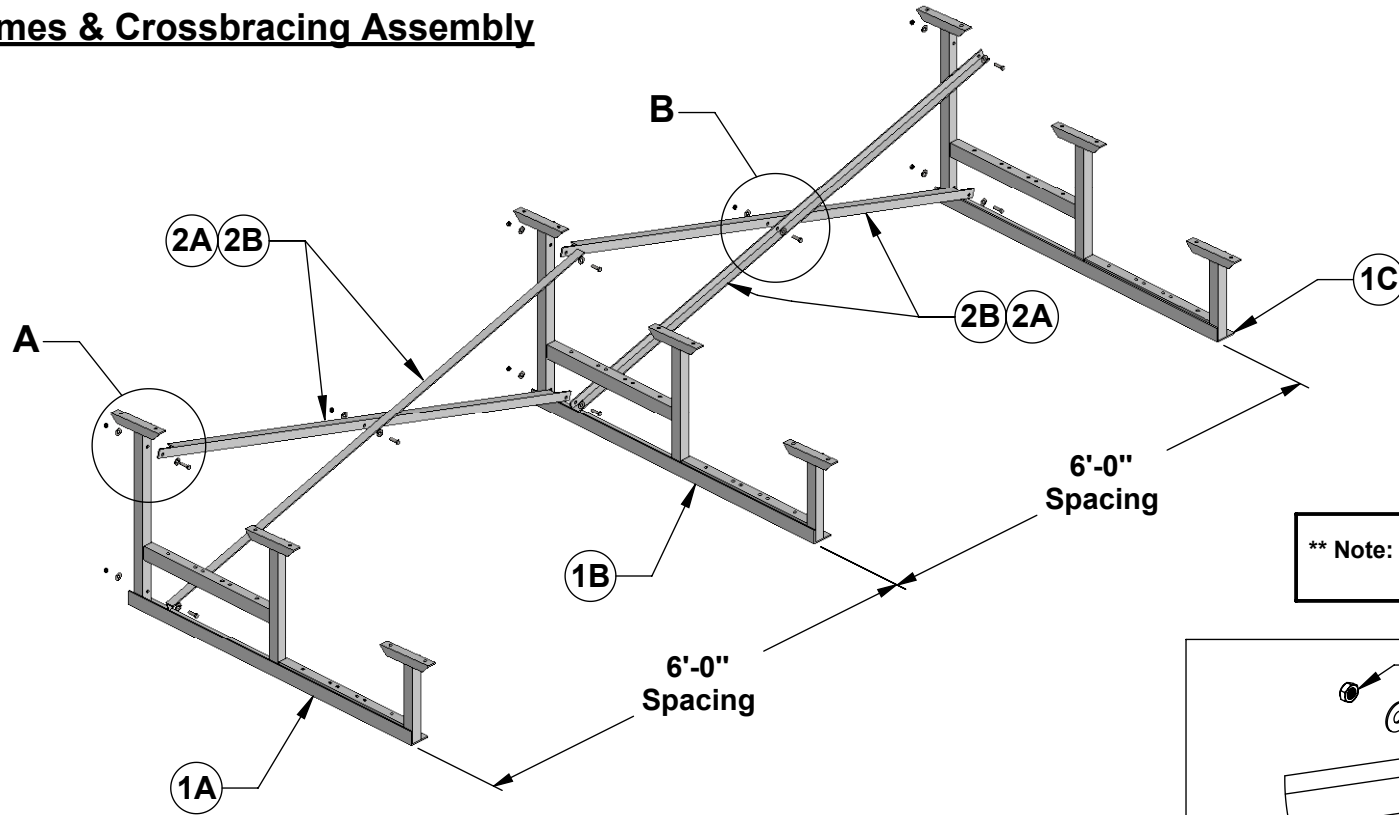

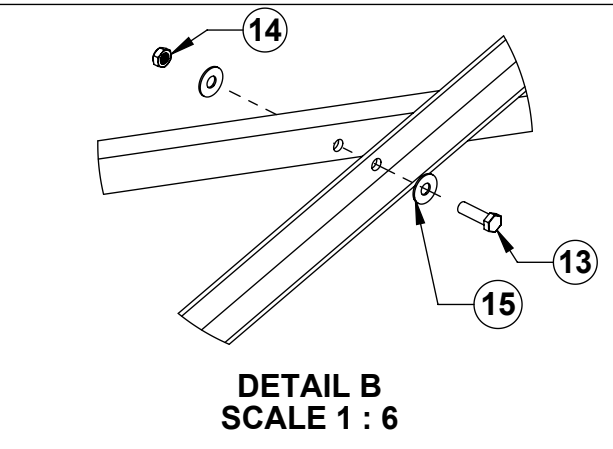

PB-315/ICC - Step No. 1
Steel Frames & Crossbracing Assembly



**** Note: Make sure, when assembling, to tighten bolt, not nut.**



Hardware Used in this Step:

-  1) 3/8"-16 x 1-1/4" S.S. Bolts (Item No.13) = 8 total
-  2) 3/8"-16 S.S. nylon-loc Nuts (Item No.14) = 8 total
-  3) 3/8" S.S. Flat Washer (Item No. 15) = 16 total

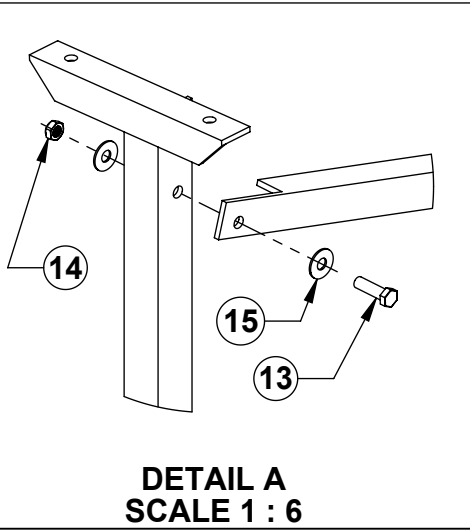

| | | | |
|---|------------------|-----------|----------------------|
|  Aluminum Athletic Equipment 1000 Enterprise Drive, Royersford, PA 19468 Toll Free: (800) 523-5471 Fax: (610) 825-2378 www.aaesports.com | | | |
| DESCRIPTION | | | |
| PB-315/ICC - Step No.1 | | | |
| NOTE: Galvanized Steel Frame & Crossbracing Assembly | | | |
| MODEL: | PB-315/ICC | CATEGORY: | CUSTOMER |
| DATE: | rev: 08/18/2022 | 11/29/01 | |
| DRAWN BY: | TAD | DETAIL: | Assembly - Step No.1 |
| DWG. NO.: | PB-315_ICC-C-001 | | |

PB-315/ICC Step No. 2
Attaching End Caps &
Planking Assembly

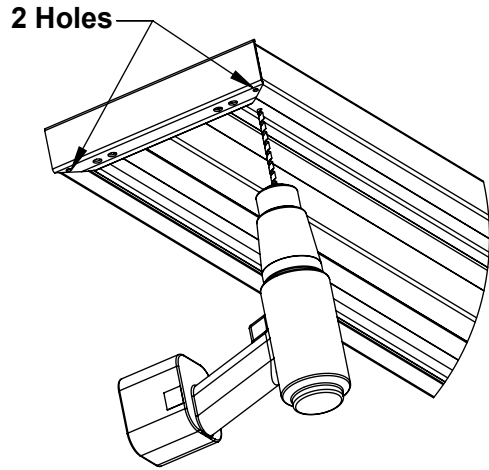

Drilling End Caps
 (for attachment to planks)

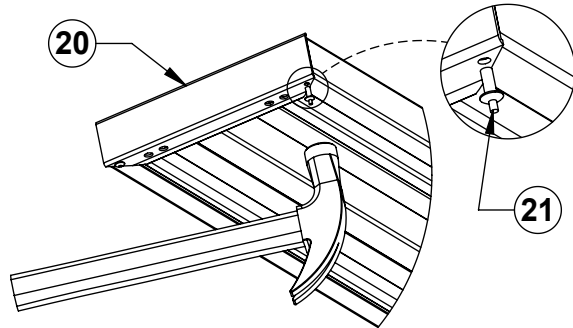
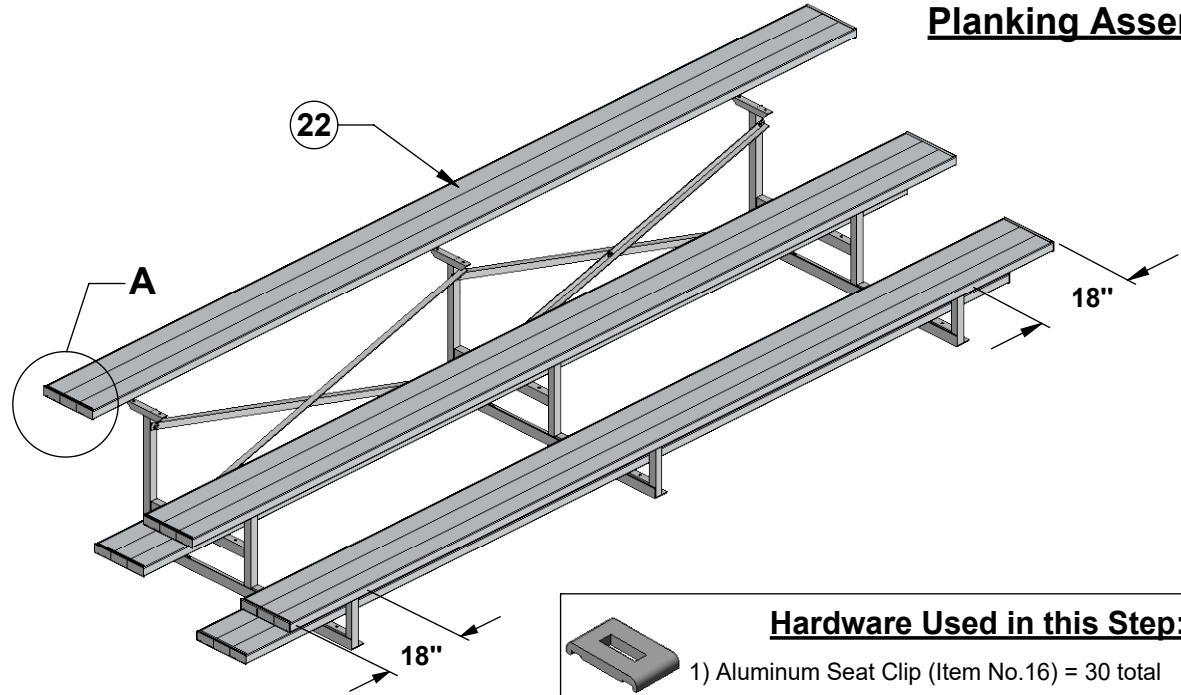

Riveting End Caps
 (for permanent attachment)

Tools Required:



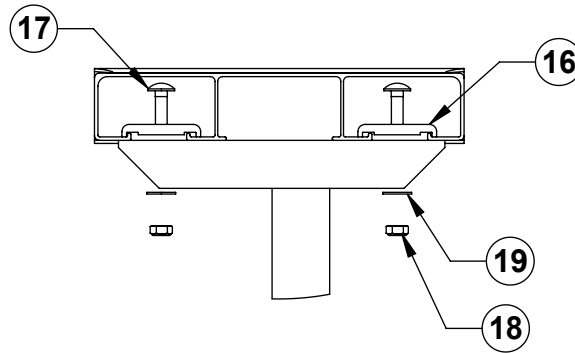

- 1) 1/2 - Ratchet
- 2) 9/16 - Ratchet
- 3) Hand Drill with 3/16" drill bit
- 4) Hammer

****Note: When assembling crossbracing, make sure to tighten the bolt end, not the nut**

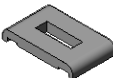

DETAIL A
Attaching Planks

Hardware Used in this Step:

-  1) Aluminum Seat Clip (Item No.16) = 30 total
-  2) 5/16"-18 x 1-1/4" S.S. Carriage Bolt (Item No.17) = 30 total
-  3) 5/16"-18 S.S. Nylon loc Nuts (Item No.18) = 30 total
-  4) 5/16" S.S. Flat Washer (Item No. 19) = 30 total
-  5) 3/16" Aluminum Rivet (Item No.21) = 20 total



Aluminum Athletic Equipment
 1000 Enterprise Drive, Royersford, PA 19468
 Toll Free: (800) 523-5471 Fax: (610) 825-2378
www.aaesports.com

| | | |
|---|-------------------------------|-----------------------------------|
| DESCRIPTION | | |
| PB-315/ICC - Step No. 2 | | |
| NOTE: Drilling End Caps & Planking Assembly | | |
| MODEL: PB-315/ICC | CATEGORY: CUSTOMER | DATE: rev: 08/18/2022 11/30/01 |
| DRAWN BY: TAD | DETAIL: Assembly - Step No. 2 | DWG. NO. PB-315_ICC-C-002 |

PB-315/ICC General Specifications

Single Footboards

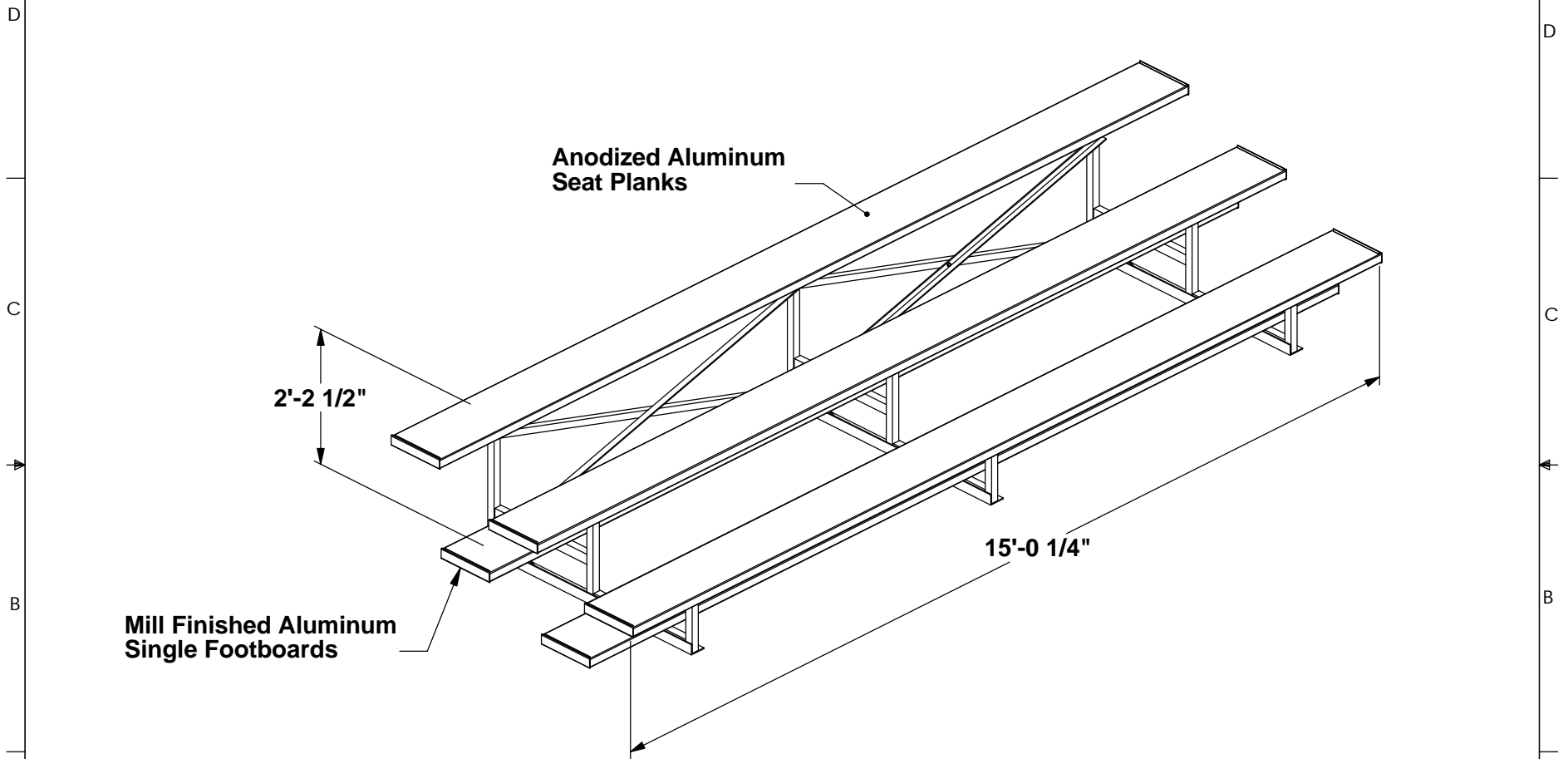

Mill Finished Aluminum
Single Footboards

Anodized Aluminum
Seat Planks

2'-2 1/2"

15'-0 1/4"

Overall Weight = 298 lbs.



Aluminum Athletic Equipment
4 Portland Road, West Conshohocken, PA 19428
Phone: (610) 825-6565 Toll Free: (800) 523-5471

| | | |
|--|--------------------------------|---------------------------|
| DESCRIPTION | | |
| PB-315/ICC - General Specifications | | |
| NOTE: 15' lg. / 3 Row / Single Footboards | | |
| MODEL: PB-315/ICC | CATEGORY: CUSTOMER | DATE: 12/5/01 |
| DRAWN BY: TAD | DETAIL: General Specifications | DWG. NO. PB-315_ICC-C-003 |

PB-315/ICC Specifications

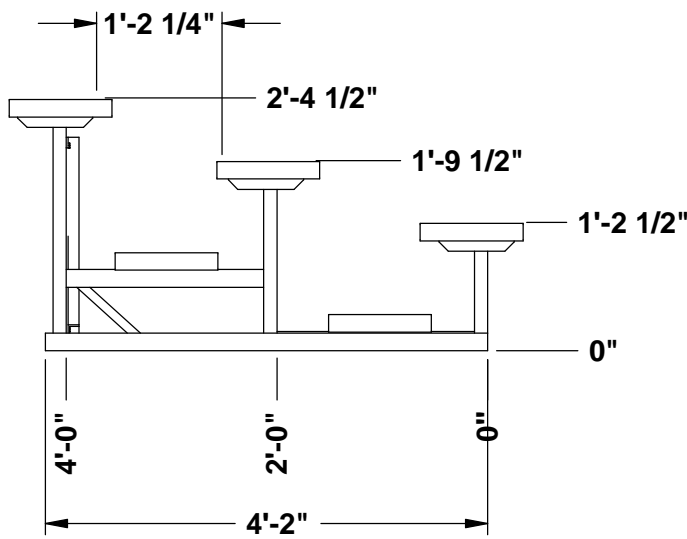
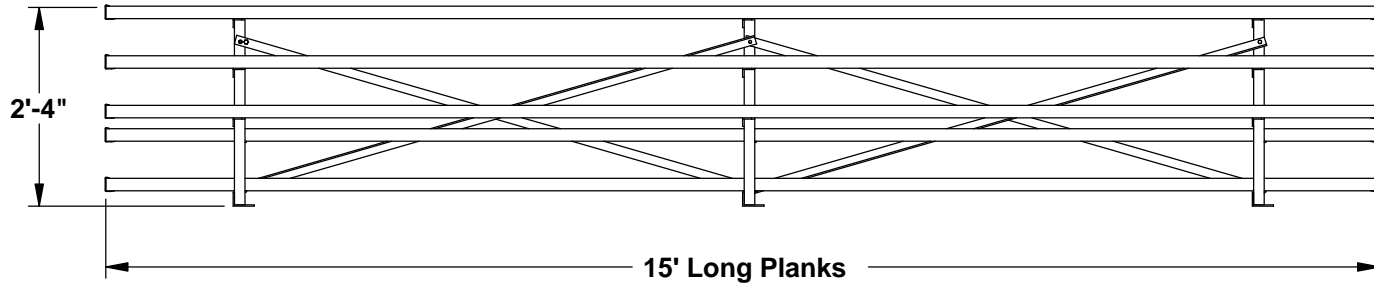

Material:

- Galvanized Steel Frames
- Aluminum Planking and Seat Clips
- Stainless Steel Hardware

| | | |
|---|-----------------|------------------|
|  Aluminum Athletic Equipment 4 Portland Road, West Conshohocken, PA 19428 Phone: (610) 825-6565 Toll Free: (800) 523-5471 | | |
| DESCRIPTION | | |
| PB-315/ICC - Specifications | | |
| NOTE: | | |
| Single Footboards | | |
| MODEL: | CATEGORY: | DATE: |
| PB-315/ICC | CUSTOMER | 12/5/01 |
| DRAWN BY: | DETAIL: | DWG. NO.: |
| TAD | Specifications | PB-315_ICC-C-004 |

**PB-315/ICC
(SINGLE FOOTBAORDS)
ASSEMBLY INSTRUCTIONS**

Step No. 1

Refer to Drawing: **Steel Frames & Crossbracing Assembly**

(*Make sure to ratchet the bolt, not the wiz-loc nut!)

1. Attach all crossbracing together at their center holes before attaching to bleacher frames using 3/8"-16 x 1-1/4" bolts, washers and 3/8"-16 nylon-loc nuts (Item Nos.13, 14, & 15).
(See "Detail B")
(ex: 2A to 2B for each side)
2. Evenly position bleacher frames (Item Nos.1A/1B/1C) approximately 6 feet apart.
3. Scissor crossbracing (Item Nos.2A/2B) and attach to bleacher frames using 3/8"-16 x 1-1/4" bolts, washers, and 3/8"-16 nylon-loc nuts (Item Nos. 13, 14, & 15).
(See "Detail A")

Step No. 2

Refer to Drawing: **Attaching End Caps & Planking**

1. Place End Caps (Item No.20) on Planks (Item No.22) and make sure they are even with the sides of the planks.
2. Using a hand drill with a 3/16" drill bit, drill through the planks where the pre-drilled holes are on the 2 outer holes on the end caps.
(See "Drilling End Caps" Detail)
3. Align 3/16" aluminum rivets (Item No.21) with newly drilled holes & hit the rivet head using any type of hammer.
(See "Riveting End Caps" Detail)
4. Attach seat and foot planks to bleacher frame accordingly **(See "Detail A")**. Each plank should overhang bleacher frame by 18" on each side. Each plank attaches to the frames at 6 locations. Tighten and check all connections.

FOR TECHNICAL ASSISTANCE, CALL 1-800-523-5471