

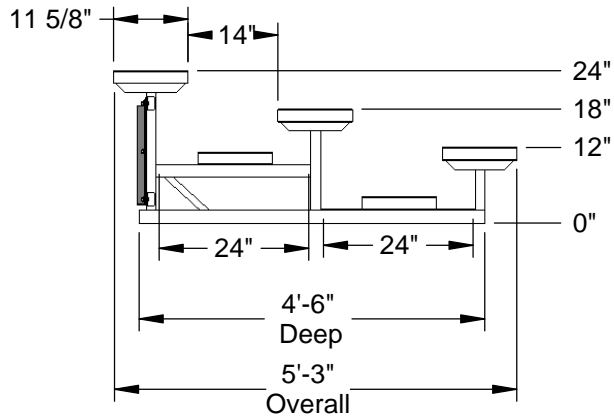

PB-321-ICC - 3 Row Bleacher Specifications

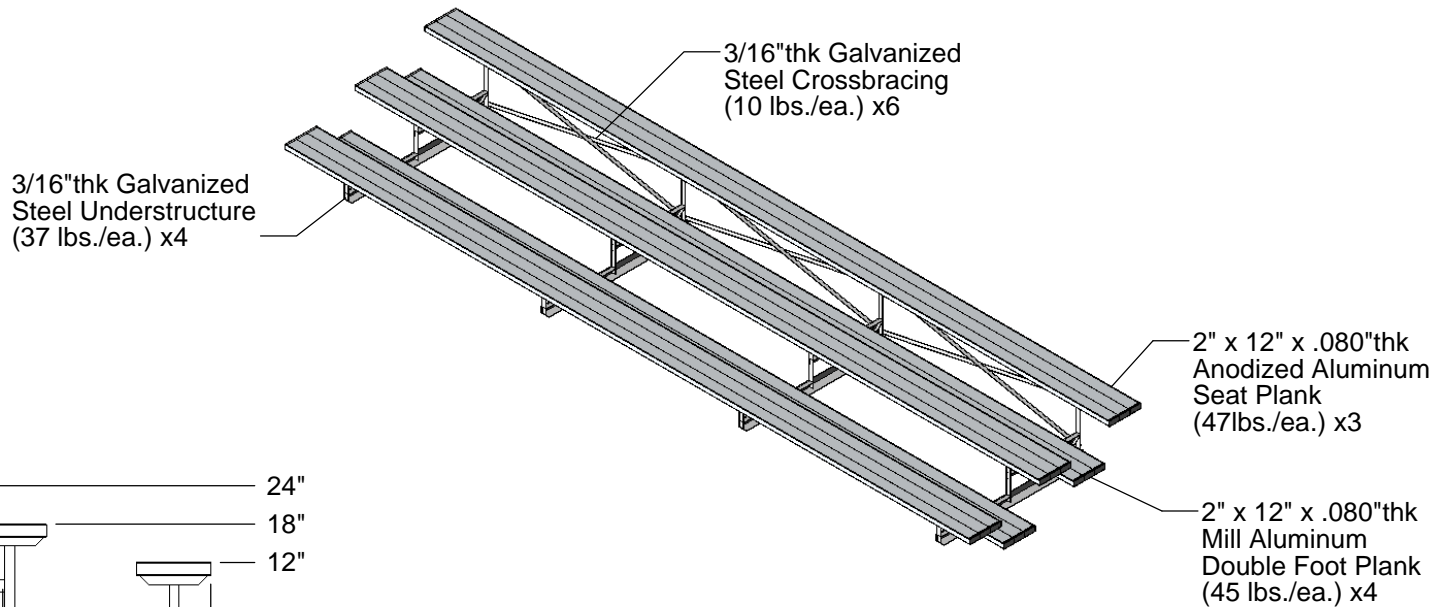
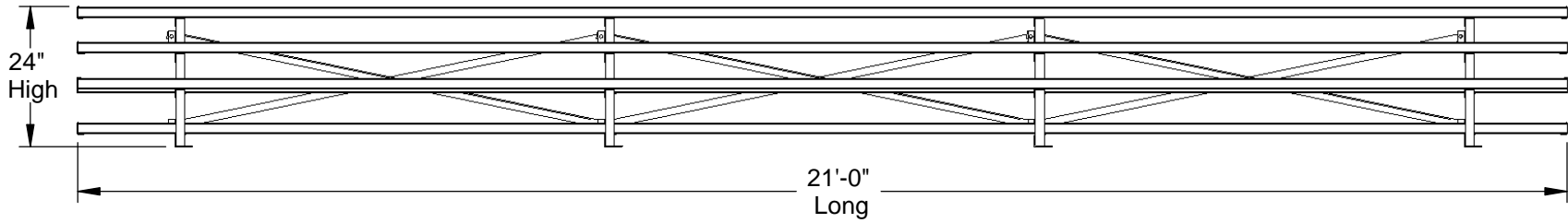

Notes:
 - Overall Weight 525lbs.
 - Meets ICC Bleacher Codes

 Aluminum Athletic Equipment 1000 Enterprise Drive, Royersford, PA 19468 Toll Free: (800) 523-5471 Fax: (610) 825-2378 www.aaesports.com		
DESCRIPTION		
PB-321-ICC - 3 Row Bleacher - Specifications		
NOTE: 21' long bleacher		
MODEL: PB-321-ICC	CATEGORY: CUSTOMER	DATE: 7/18/13
DWN. BY: TAD	CAD FILE: PB-321-ICC - Specifications	DWG. NO. PB-321-ICC-C-001

PB-321/ICC - Step No. 1

Steel Frames & Crossbracing Assembly

D

C

B

A

D

C

B

A

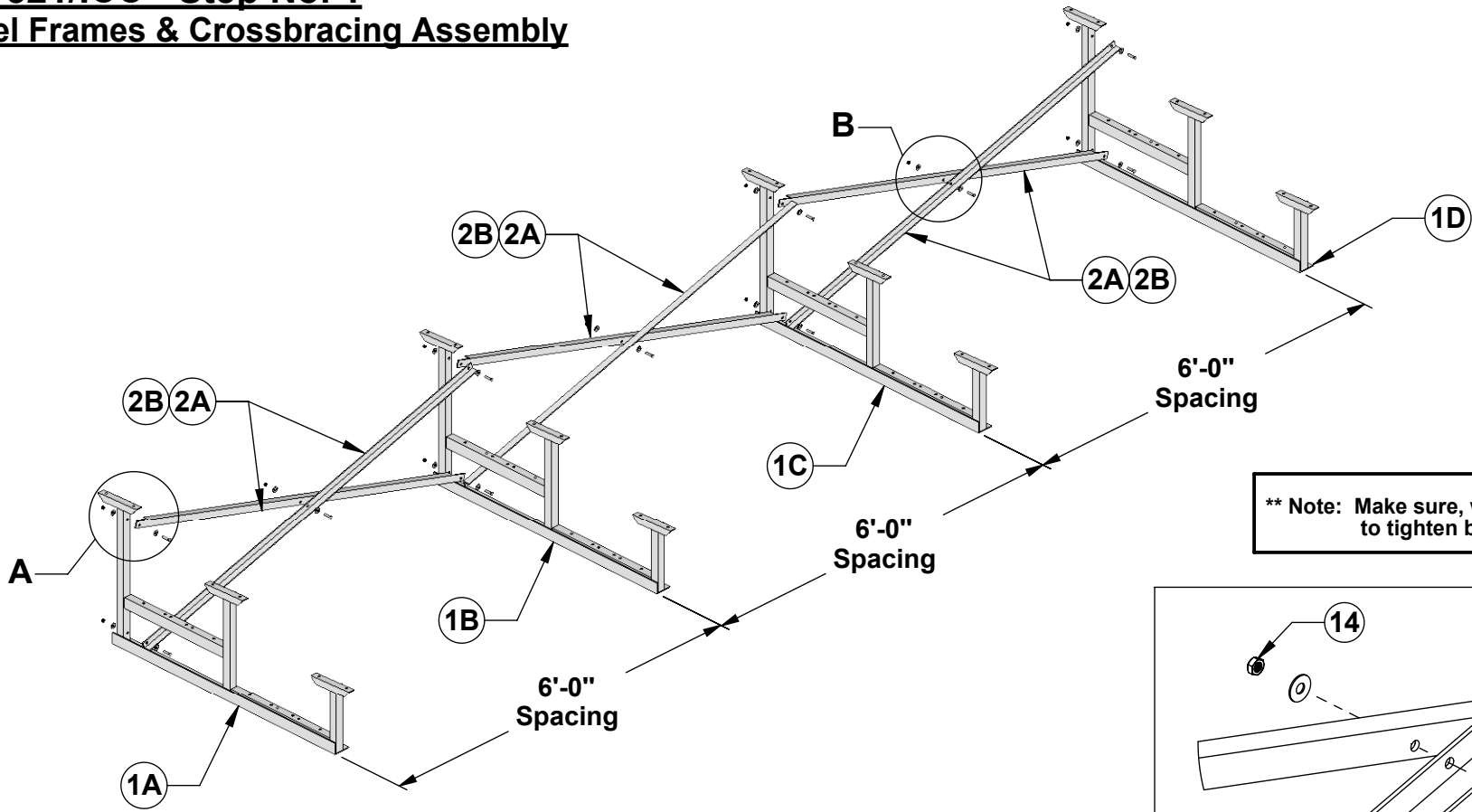

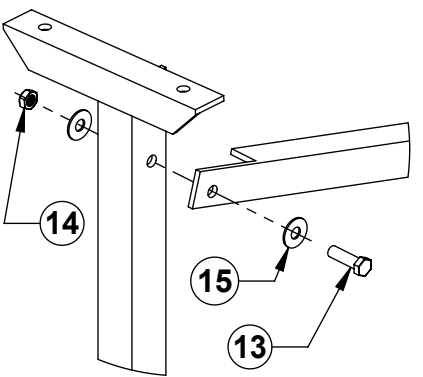
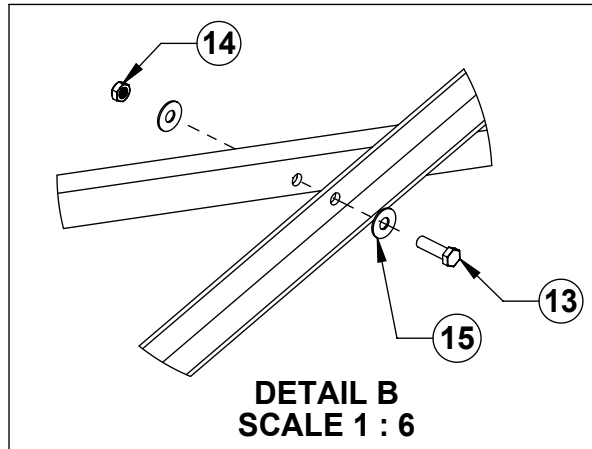

**** Note: Make sure, when assembling, to tighten bolt, not nut.**



DETAIL A
SCALE 1 : 6

Hardware Used in this Step:

-  1) 3/8"-16 x 1-1/4" S.S. Bolts (Item No.13) = 11 total
-  2) 3/8"-16 S.S. nylon-loc Nuts (Item No.14) = 11 total
-  3) 3/8" S.S. Flat Washer (Item No. 15) = 22 total



Aluminum Athletic Equipment
1000 Enterprise Drive, Royersford, PA 19468
Toll Free: (800) 523-5471 Fax: (610) 825-2378
www.aaesports.com

DESCRIPTION			
PB-321/ICC - Step No.1			
NOTE: Galvanized Steel Frame & Crossbracing Assembly			
MODEL:	PB-321/ICC	CATEGORY:	CUSTOMER
DRAWN BY:	TAD	DATE:	rev: 08/18/2022 11/29/01
DETAIL:	Assembly - Step No.1		DWG. NO. PB-321_ICC-C-001

6

5

4

3

2

1

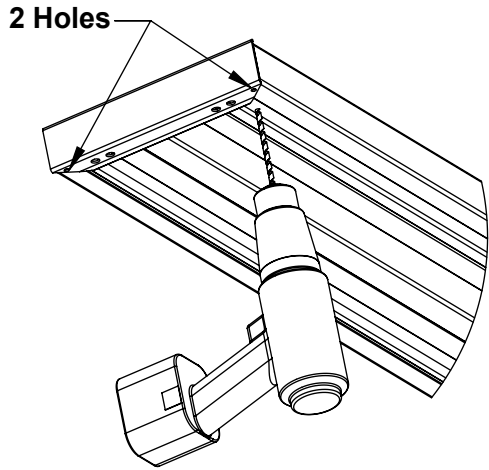

2 Holes

Drilling End Caps
(for attachment to planks)

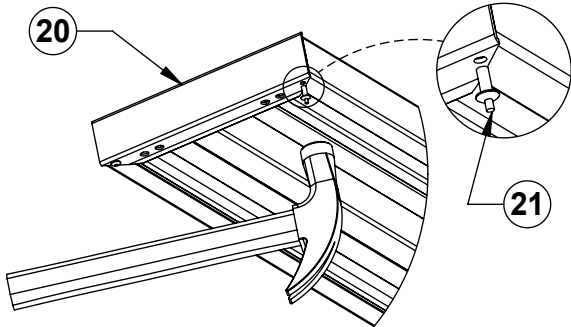

Riveting End Caps
(for permanent attachment)

Tools Required:

- 1) 1/2" - Ratchet
- 2) 9/16" - Ratchet
- 3) Hand Drill with 3/16" drill bit
- 4) Hammer



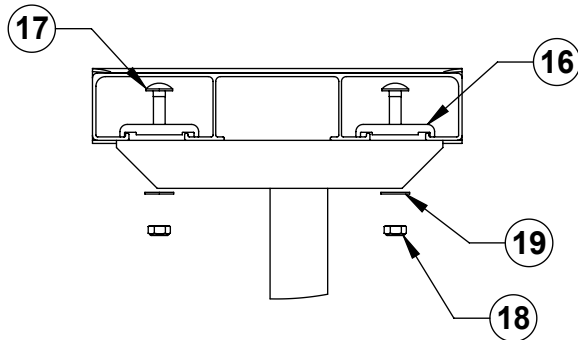
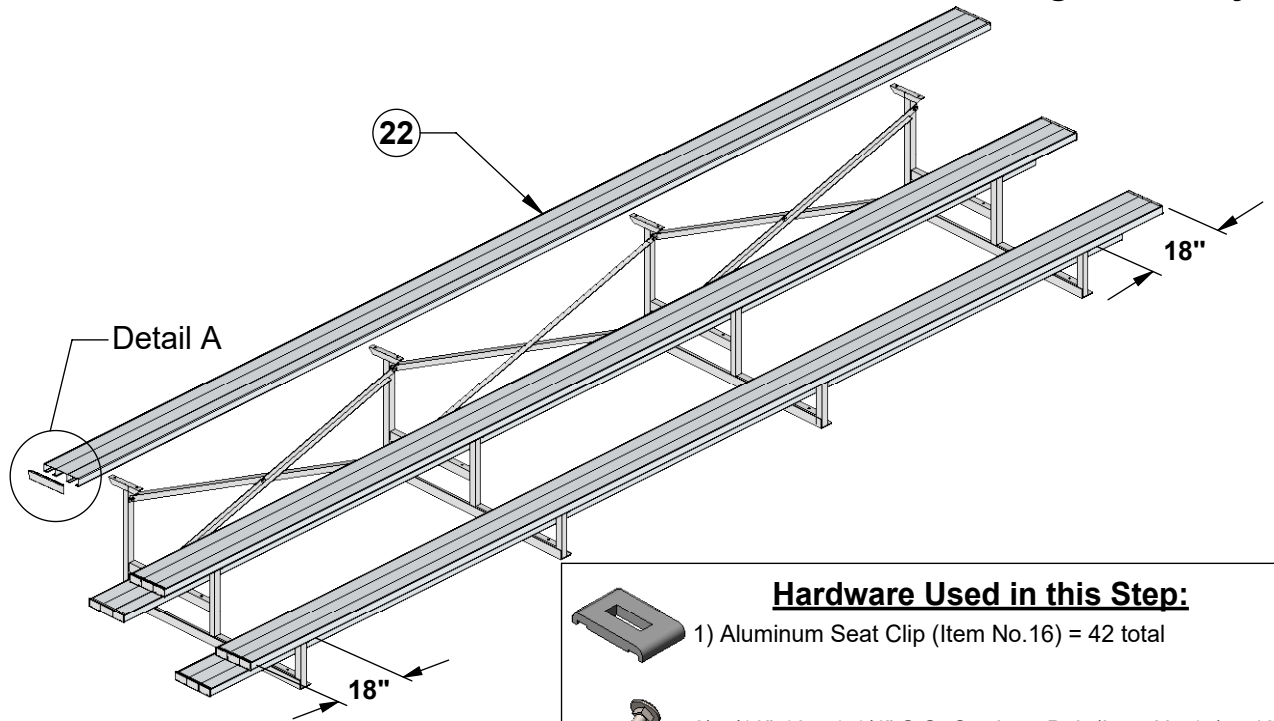

****Note: When assembling crossbracing, make sure to tighten the bolt end, not the nut**

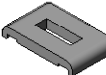

DETAIL A
Attaching Planks

PB-321/ICC Step No. 2
Attaching End Caps & Planking Assembly

Hardware Used in this Step:

-  1) Aluminum Seat Clip (Item No.16) = 42 total
-  2) 5/16"-18 x 1-1/4" S.S. Carriage Bolt (Item No.17) = 42 total
-  3) 5/16"-18 S.S. Nylon loc Nuts (Item No.18) = 42 total
-  4) 5/16" S.S. Flat Washer (Item No. 19) = 42 total
-  5) 3/16" Aluminum Rivet (Item No.21) = 28 total



Aluminum Athletic Equipment
1000 Enterprise Drive, Royersford, PA 19468
Toll Free: (800) 523-5471 Fax: (610) 825-2378
www.aaesports.com

DESCRIPTION		
PB-321/ICC - Step No. 2		
NOTE: Drilling End Caps & Planking Assembly		
MODEL: PB-321/ICC	CATEGORY: CUSTOMER	DATE: rev: 08/18/2022 11/30/01
DRAWN BY: TAD	CAD FILE: PB-321/ICC Step No. 2	DWG. NO. PB-321_ICC-C-002

PB-321/ICC Specifications

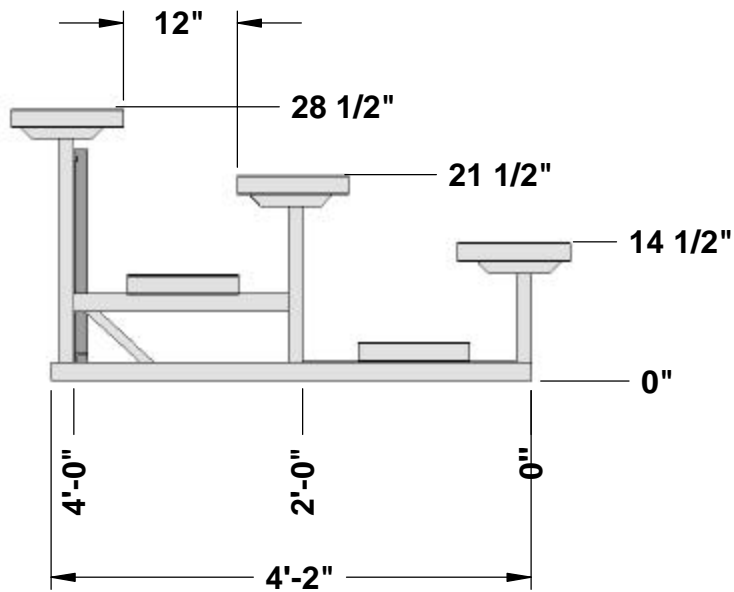
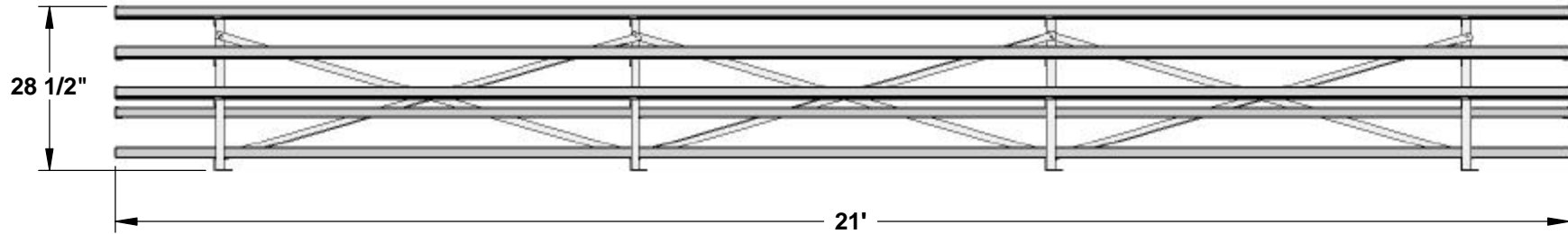

Material:

Galvanized Steel Frames
Aluminum Planking and Seat Clips
Stainless Steel Hardware



Aluminum Athletic Equipment
 4 Portland Road, West Conshohocken, PA 19428
 Phone: (610) 825-6565 Toll Free: (800) 523-5471

DESCRIPTION		
PB-321/ICC - Specifications		
NOTE: Single Footboards		
MODEL: PB-321/ICC	CATEGORY: CUSTOMER	DATE: 6/4/03
DWN. BY: TAD	CAD FILE: PB-321_ICC Specifications	DWG. NO. PB-321_ICC-C-004

**PB-321/ICC
(SINGLE FOOTBOARDS)
ASSEMBLY INSTRUCTIONS**

Step No. 1

Refer to Drawing: **Steel Frames & Crossbracing Assembly**

(*Make sure to ratchet the bolt, not the wiz-loc nut!)

1. Attach all crossbracing together at their center holes before attaching to bleacher frames using 3/8"-16 x 1-1/4" bolts, washers and 3/8"-16 nylon-loc nuts (Item Nos.13, 14, & 15).
(See "Detail B")
(ex: 2A to 2B for each side)
2. Evenly position bleacher frames (Item Nos.1A/1B/1C/1D) approximately 6 feet apart.
3. Scissor crossbracing (Item Nos.2A/2B) and attach to bleacher frames using 3/8"-16 x 1-1/4" bolts, washers, and 3/8"-16 nylon-loc nuts (Item Nos. 13, 14, & 15).
(See "Detail A")

Step No. 2

Refer to Drawing: **Attaching End Caps & Planking**

1. Place End Caps (Item No.20) on Planks (Item No.22) and make sure they are even with the sides of the planks.
2. Using a hand drill with a 3/16" drill bit, drill through the planks where the pre-drilled holes are on the 2 outer holes on the end caps.
(See "Drilling End Caps" Detail)
3. Align 3/16" aluminum rivets (Item No.21) with newly drilled holes & hit the rivet head using any type of hammer.
(See "Riveting End Caps" Detail)
4. Attach seat and foot planks to bleacher frame accordingly **(See "Detail A")**. Each plank should overhang bleacher frame by 18" on each side. Each plank attaches to the frames at 8 locations. Tighten and check all connections.

FOR TECHNICAL ASSISTANCE, CALL 1-800-523-5471