

# PB-421/ICC

## General Specifications

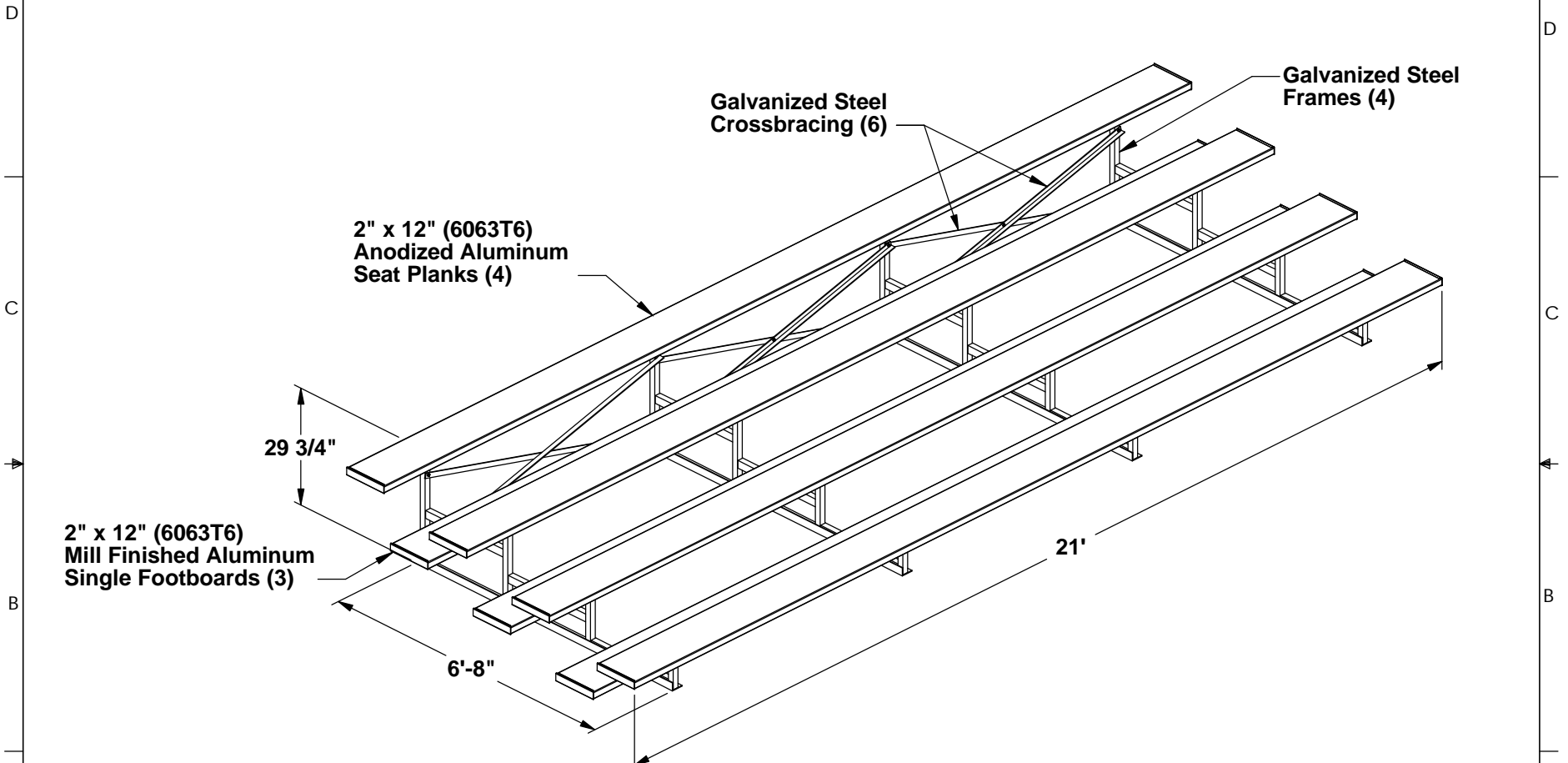

**Overall Weight = 380 lbs.**



Aluminum Athletic Equipment  
 4 Portland Road, West Conshohocken, PA 19428  
 Phone: (610) 825-6565 Toll Free: (800) 523-5471

DESCRIPTION		
<b>PB-421/ICC General Specifications</b>		
NOTE: 21' Long Planks / 4 Row		
MODEL:	CATEGORY:	DATE:
PB-421/ICC	<b>CUSTOMER</b>	6/12/02
DWN. BY:	CAD FILE:	DWG. NO.:
TAD	PB-421/ICC General Specs	PB421-ICC-C-001

# PB-421/ICC - Specifications

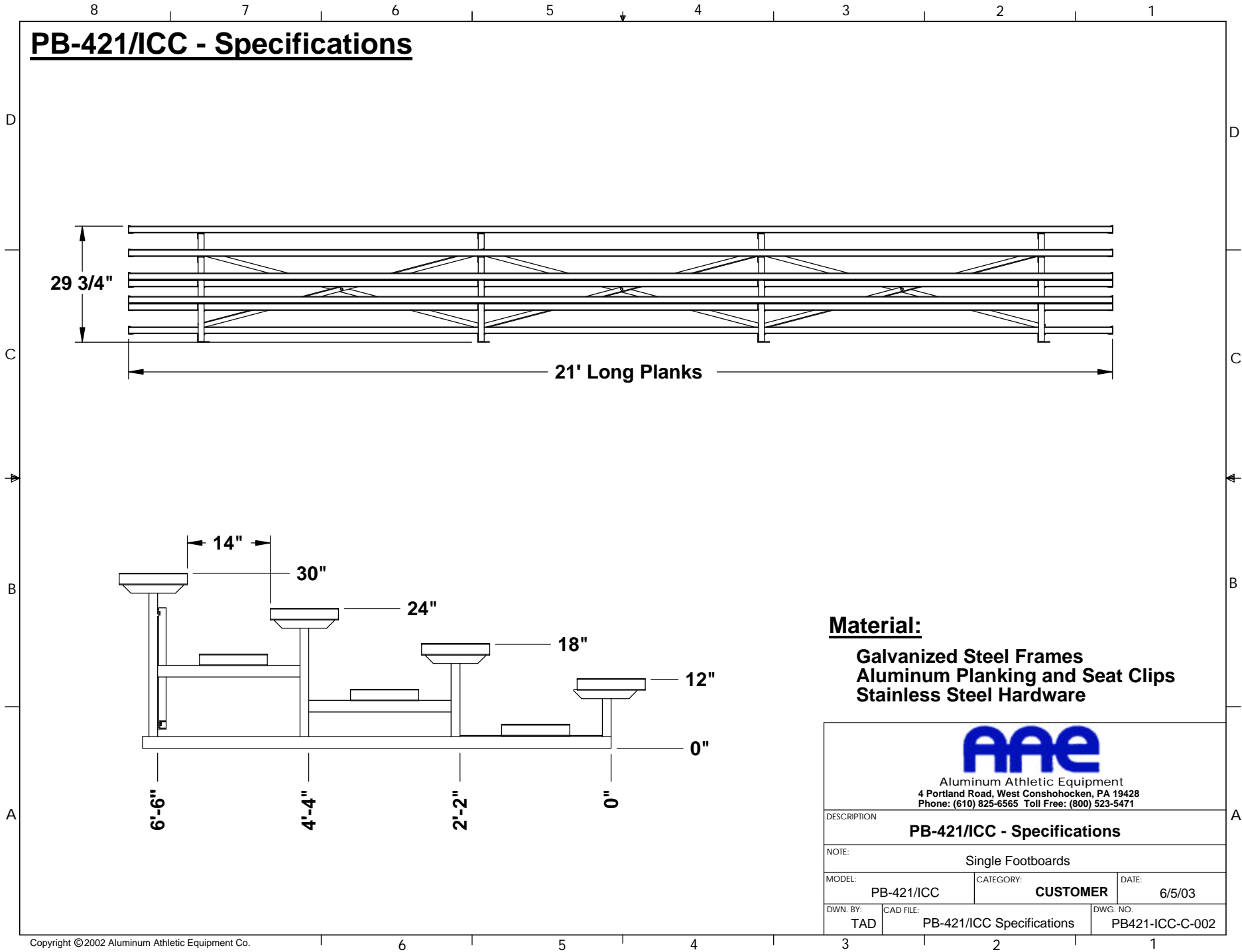

**Material:**

Galvanized Steel Frames  
 Aluminum Planking and Seat Clips  
 Stainless Steel Hardware



 Aluminum Athletic Equipment 4 Portland Road, West Conshohocken, PA 19428 Phone: (610) 825-6565 Toll Free: (800) 523-5471			
DESCRIPTION			
<b>PB-421/ICC - Specifications</b>			
NOTE:			
Single Footboards			
MODEL:	PB-421/ICC	CATEGORY:	CUSTOMER
		DATE:	6/5/03
DWN. BY:	TAD	CAD FILE:	PB-421/ICC Specifications
		DWG. NO.:	PB421-ICC-C-002

# PB-421-ICC - Step No. 1

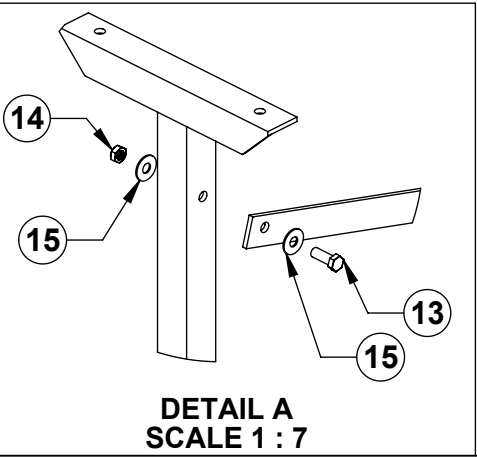
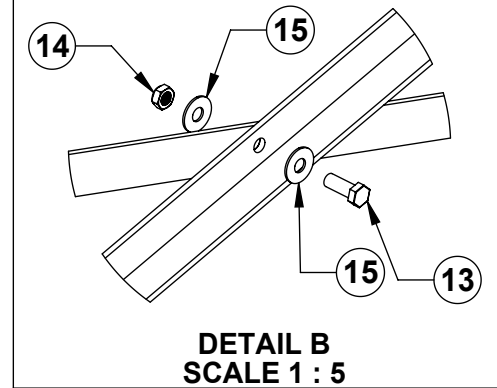
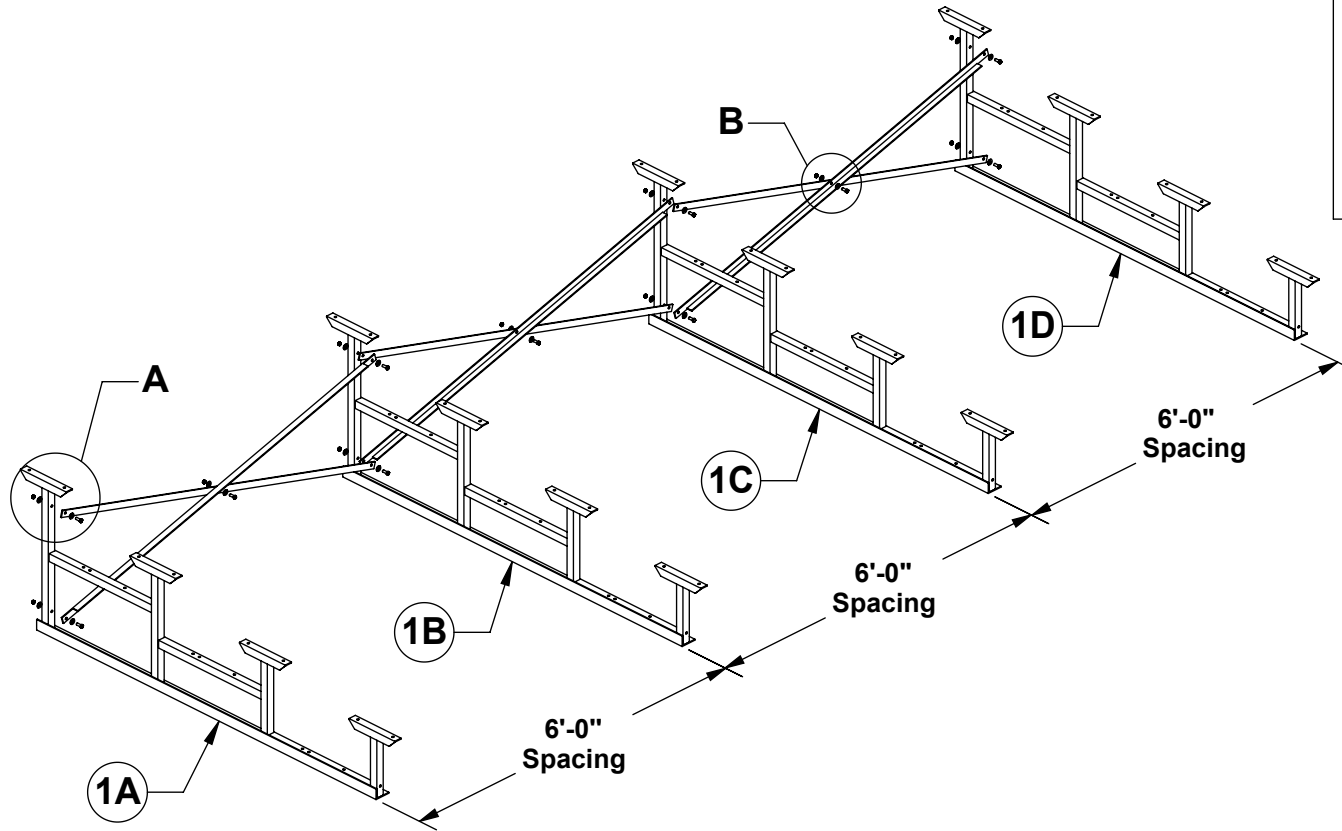
## Steel Frames & Crossbracing Assembly



### Hardware Used in this Step:

-  1) 3/8"-16 x 1-1/4" S.S. Bolts (Item No.13) = 11 total
-  2) 3/8"-16 S.S. nylon-loc Nuts (Item No.14) = 11 total
-  3) 3/8" S.S. Flat Washer (Item No. 15) = 22 total

**\*\* Note: Make sure, when assembling, to ratchet bolt, not nut.**



**Aluminum Athletic Equipment**  
1000 Enterprise Drive, Royersford, PA 19468  
Toll Free: (800) 523-5471 Fax: (610) 825-2378  
www.aaesports.com

DESCRIPTION			<b>PB-421-ICC - Step No. 1</b>		
NOTE:			Galvanized Steel Frame & Crossbracing Assembly		
MODEL:	CATEGORY:	DATE:	rev: 08/18/2022		
PB-421-ICC	CUSTOMER	10/16/02			
DRAWN BY:	CAD FILE:	DWG. NO.:			
TAD	PB-421-ICC - Step No. 1	PB-421-ICC-C-003			

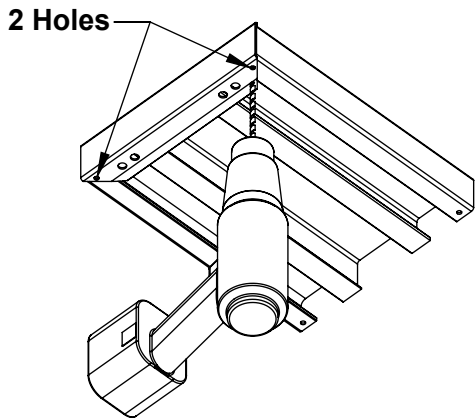

2 Holes

**Drilling End Caps**  
(for attachment to planks)

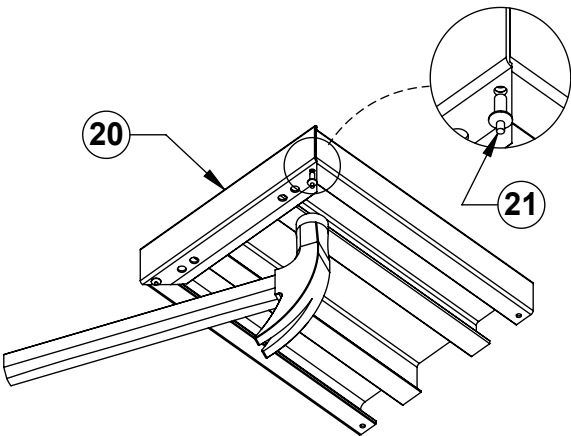

**Riveting End Caps**  
(for permanent attachment)

**Tools Required:**

- 1) 1/2" - Ratchet
- 2) 9/16" - Ratchet
- 3) Hand Drill with 3/16" drill bit
- 4) Hammer



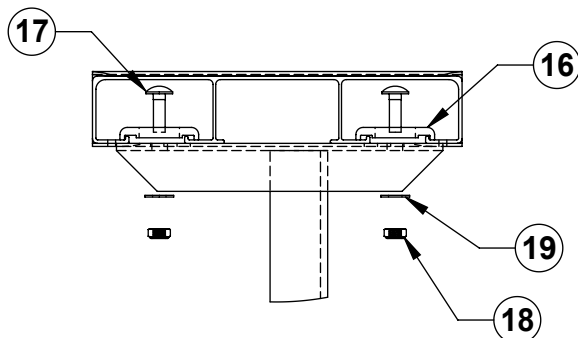
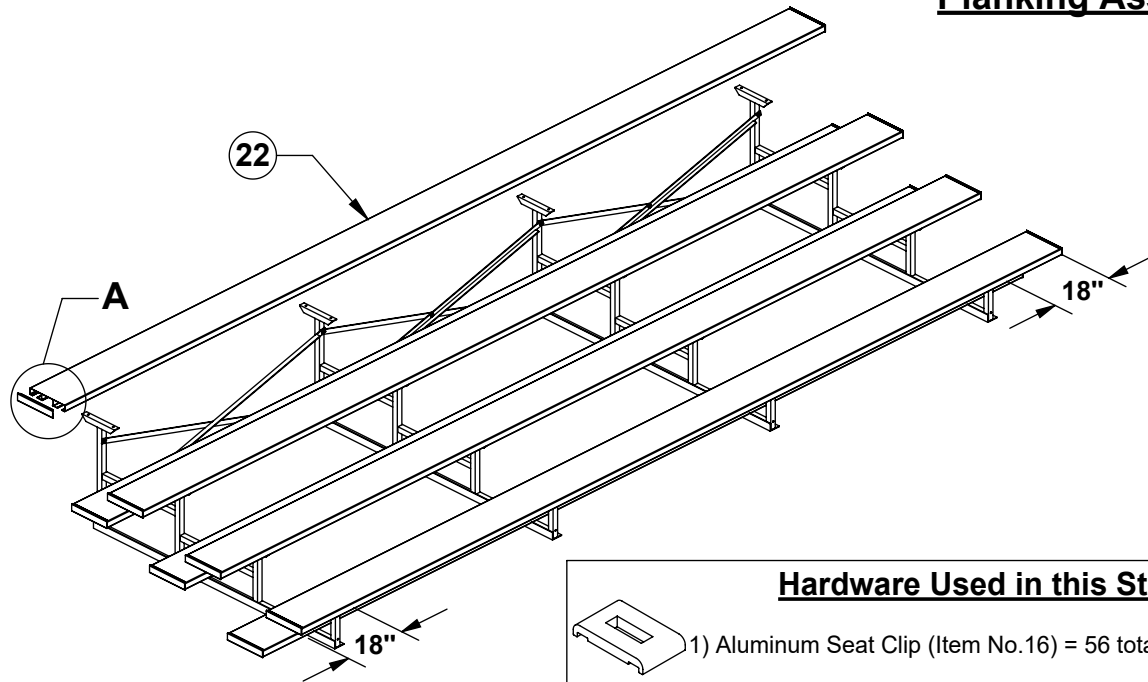

**\*\*Note: When assembling crossbracing, make sure to tighten the bolt end, not the nut**

**PB-421-ICC Step No. 2**  
**Attaching End Caps & Planking Assembly**



**DETAIL A**  
**Attaching Planks**

**Hardware Used in this Step:**

-  1) Aluminum Seat Clip (Item No.16) = 56 total
-  2) 5/16"-18 x 1-1/4" S.S. Carriage Bolt (Item No.17) = 56 total
-  3) 5/16"-18 S.S. Nylon loc Nuts (Item No.18) = 56 total
-  4) 5/16" S.S. Flat Washer (Item No. 19) = 56 total
-  5) 3/16" Aluminum Rivet (Item No.21) = 28 total



**Aluminum Athletic Equipment**  
1000 Enterprise Drive, Royersford, PA 19468  
Toll Free: (800) 523-5471 Fax: (610) 825-2378  
[www.aaesports.com](http://www.aaesports.com)

DESCRIPTION		
<b>PB-421-ICC - Step No. 2</b>		
NOTE: Drilling End Caps & Planking Assembly		
MODEL: PB-421-ICC	CATEGORY: CUSTOMER	DATE: rev: 08/18/2022 11/30/01
DRAWN BY: TAD	CAD FILE: PB-421-ICC - Step No. 2	DWG. NO. PB-421-ICC-C-004

**PB-421/ICC  
(SINGLE FOOTBOARDS)  
ASSEMBLY INSTRUCTIONS**

---

**Step No. 1**

Refer to Drawing: **Steel Frames & Crossbracing Assembly**

(\*Make sure to ratchet the bolt, not the wiz-loc nut!)

1. Attach all crossbracing together at their center holes before attaching to bleacher frames using 3/8"-16 x 1-1/4" bolts, washers, and 3/8"-16 nylon-loc nuts (Item Nos.13, 14, & 15).  
**(See "Detail B")**  
**(ex: 2A to 2B for each side)**
2. Evenly position bleacher frames (Item Nos.1A/1B/1C/1D) approximately 6 feet apart.
3. Scissor crossbracing (Item Nos.2A/2B) and attach to bleacher frames using 3/8"-16 x 1-1/4" bolts, washers, and 3/8"-16 nylon-loc nuts (Item Nos. 13, 14, & 15).  
**(See "Detail A")**

**Step No. 2**

Refer to Drawing: **Attaching End Caps & Planking**

1. Place End Caps (Item No.20) on Planks (Item No.22) and make sure they are even with the sides of the planks.
2. Using a hand drill with a 3/16" drill bit, drill through the planks where the pre-drilled holes are on the 2 outer holes on the end caps.  
**(See "Drilling End Caps" Detail)**
3. Align 3/16" aluminum rivets (Item No.21) with newly drilled holes & hit the rivet head using any type of hammer.  
**(See "Riveting End Caps" Detail)**
4. Attach seat and foot planks to bleacher frame accordingly **(See "Detail A")**. Each plank should overhang bleacher frame by 18" on each side. Each plank attaches to the frames at 8 locations. Tighten and check all connections.

**FOR TECHNICAL ASSISTANCE, CALL 1-800-523-5471**