

AAE Model No. PFS-NCAA NCAA Pit Form System

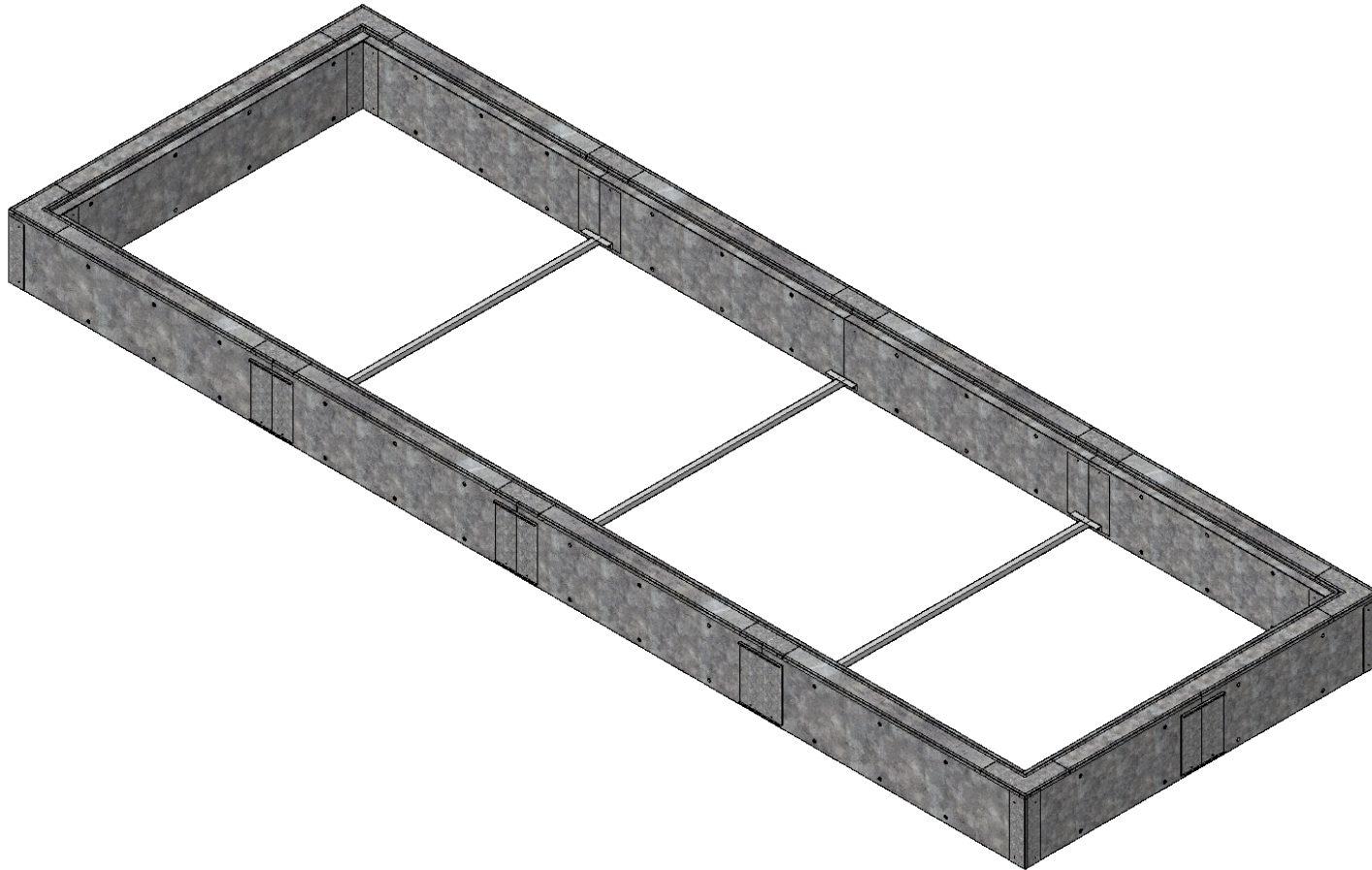

Aluminum Athletic Equipment
1000 Enterprise Drive, Royersford, PA 19468
Toll Free: (800) 523-5471 Fax: (610) 825-2378
www.AAEsports.com

PFS-NCAA - College Pit Form

Long/Triple Jump Pit

Layout Specifications

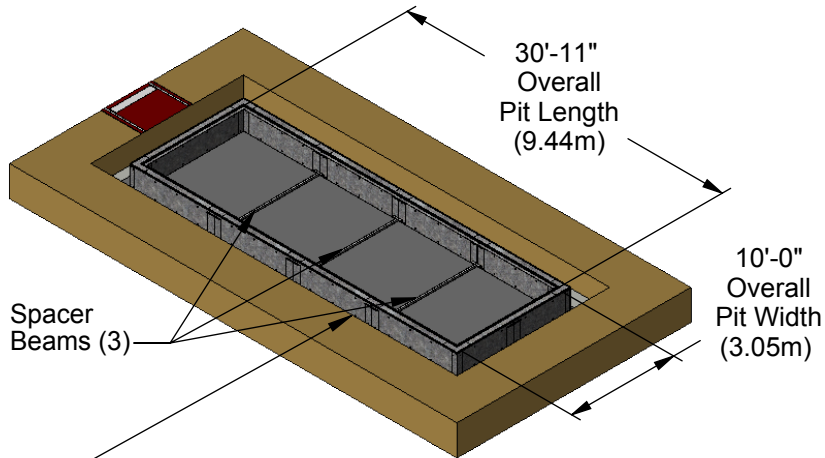

- Stainless Steel (12 ga. - 304 2B finish) Inner Panels
- Galvanized Steel (12 ga.) Outer Panels

Isometric View

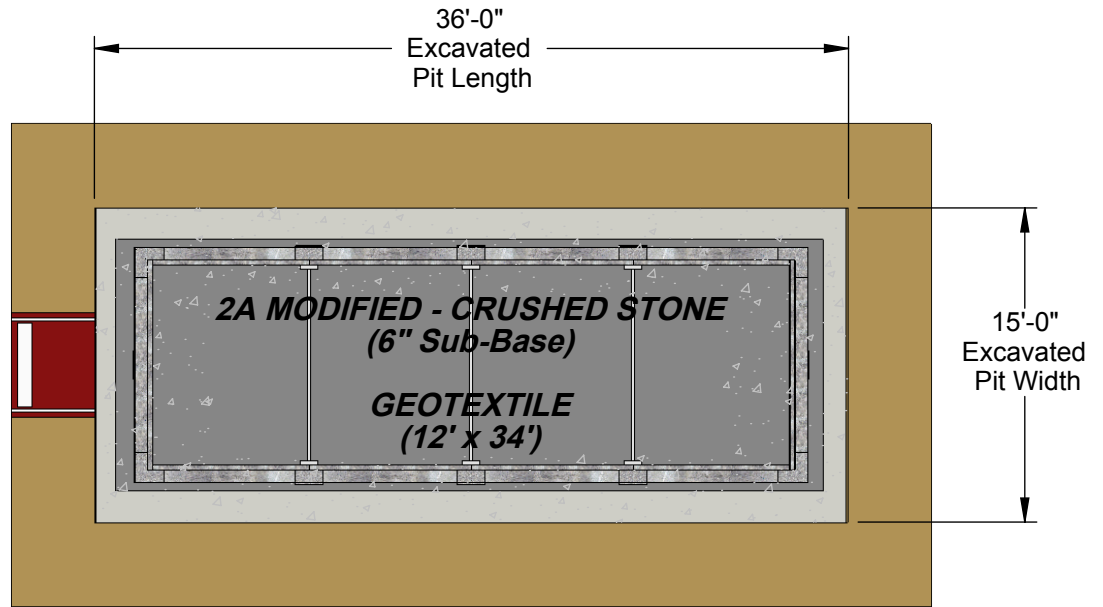

Plan View

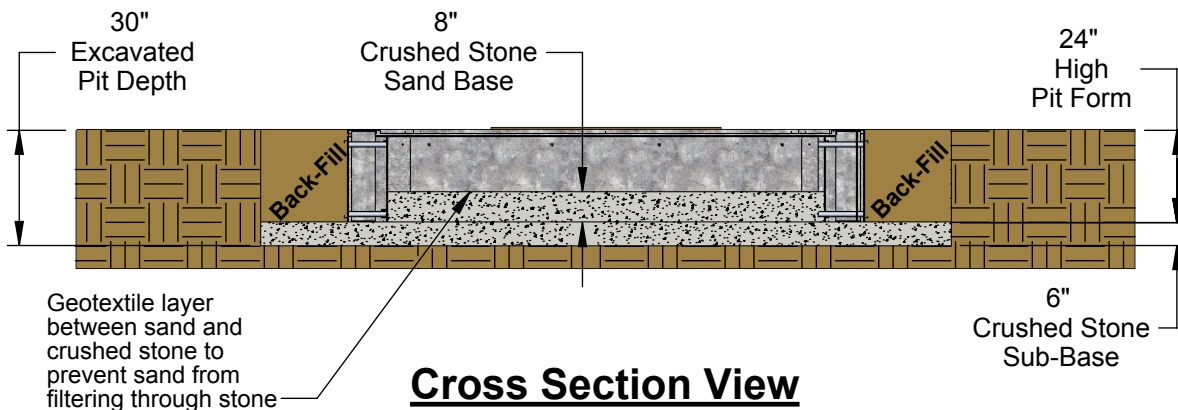

Cross Section View

 Aluminum Athletic Equipment 1000 Enterprise Drive, Royersford, PA 19468 Toll Free: (800) 523-5471 Fax: (610) 825-2378 www.AAEsports.com		
DESCRIPTION:		
PFS-NCAA- College Pit Form - Layout Specifications		
NOTE:		
Stainless Steel Pit Form Layout		
MODEL:	CATEGORY:	DATE:
PFS-NCAA	CUSTOMER	07/21/11
DWN. BY:	CAD FILE:	DWG. NO.:
TAD	PFS-NCAA Packet	PFS-NCAA-C-001

PFS-NCAA Pit Form Specifications

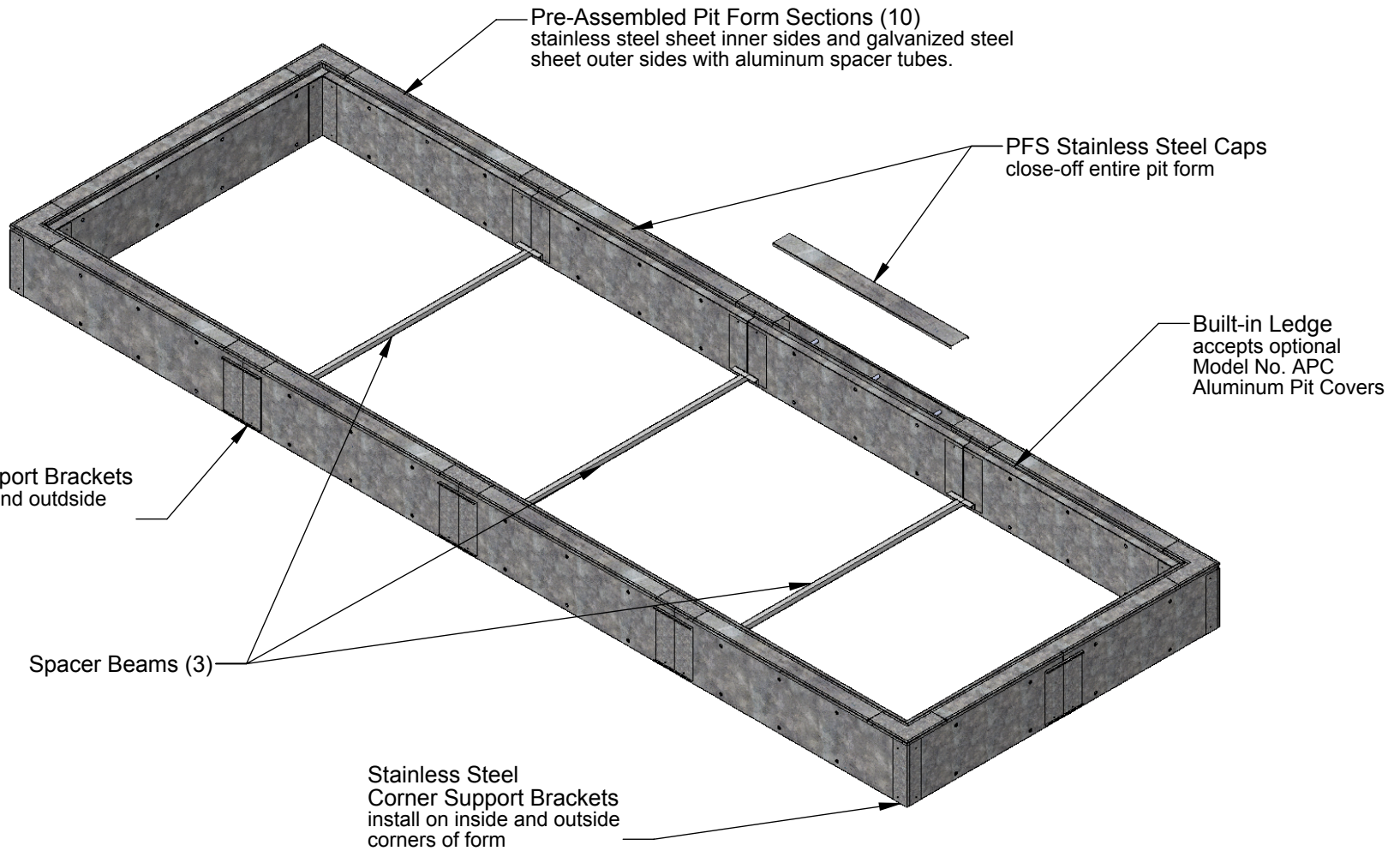

Notes:

- No concrete required
- Stainless Steel (12 ga. - 304 2B) pre-fabricated pit form inner sides, support brackets, and caps
- Galvanized Steel (12 ga.) pre-fabricated pit form outer sides
- Sections are shipped pre-assembled (10 sections)
- Overall Weight = 2,300 lbs



Aluminum Athletic Equipment
1000 Enterprise Drive, Royersford, PA 19468
Toll Free: (800) 523-5471 Fax: (610) 825-2378
www.AAEsports.com

DESCRIPTION:		
PFS-NCAA - Pit Form Specifications		
NOTE: Pit Form Details		
MODEL:	CATEGORY:	DATE:
PFS-NCAA	CUSTOMER	07/21/11
DWN. BY:	CAD FILE:	DWG. NO.:
TAD	PFS-NCAA Packet	PFS-NCAA-C-002

PFS-NCAA Assembly

C-Channel Support Brackets
install on inside and outside
walls of pit form system

Spacer Beams (3)

DETAIL A
SCALE 1 : 30

Corner Support Brackets
install on inside and outside
corners fo pit form system

DETAIL B
SCALE 1 : 30

 Aluminum Athletic Equipment 1000 Enterprise Drive, Royersford, PA 19468 Toll Free: (800) 523-5471 Fax: (610) 825-2378 www.AAEsports.com		
DESCRIPTION:		
PFS-NCAA - Assembly		
NOTE:		
PFS-NCAA Callout Assembly Sheet		
MODEL:	CATEGORY:	DATE:
PFS-NCAA	CUSTOMER	07/21/11
DWN. BY:	CAD FILE:	DWG. NO.:
TAD	PFS-NCAA Packet	PFS-NCAA-C-003

**PFS & SSC
PIT FORM SYSTEM & SAND STORAGE COMPARTMENT
INSTALLATION INSTRUCTIONS**

A. PRE-INSTALLATION

Pit Form System: Placement

1. Refer to architectural drawings and plans for the placement of the pit form system to be installed.

Notes:

Long Jump Event for both NCAA Men's & HS Boy's take-off board are to be positioned 12' from the front inside edge of the pit to the edge of the take-off board closest to the pit. And 8' from the inside edge of the pit to the edge of the take-off board closest to the pit for HS Girls.

2. PFS-HS: a pit shall be excavated (equally centered off the planned runway) at least 15' wide by 28' in length and a minimum of 34" below finished grade level.
PFS-NCAA: a pit shall be excavated (equally centered off the planned runway) at least 15' wide by 36' in length and a minimum of 34" below finished grade level.
3. Use 2A modified crushed stone as the base surface and compact to 80% to 85% approximately 24-1/2" below finished grade level (or top of track surface)
4. Level pit area out and fill any uneven surfaces, make sure to compact area again.

B. ASSEMBLY

AAE's Pit Forms come pre-assembled in sections to assist the customer!

1. **IMPORTANT NOTE:**
If a PFS-SSC Sand Storage Compartment was purchased; Make Sure to install with the PFS-SSC Installation Holes on the far end of the pit! Furthest side from the runway!
2. For reference, the distance from the inside edge of the pit to the first take-off board on the runway should be 8'-0".
3. Use a string-line and center the line down the runway and place at far end of pit form excavation area. Center form between A & B and G & H.
4. Refer to drawing PFS-HS-C-002, and assemble accordingly using stainless steel hardware, C-Channel Supports Brackets, Corner Support Brackets, and Form Caps.
5. Install the included aluminum "Spacer Beams" to help maintain the correct width of the pit. Also cut 3 pieces of 2x4 at a length of 120" to shim between the top ledge of the pit for temporary install before Step #8- Before Back-Filling.
6. Squaring the pit form: Measure diagonally between corners B & H and A & G. Dimension should be approximately 322-1/2" .

PFS & SSC PIT FORM SYSTEM & SAND STORAGE COMPARTMENT INSTALLATION INSTRUCTIONS

7. Screw in 16" long Access Caps at C,D,E & F locations and Corner caps at A,B,G & H.
- 8.. Before Back-Filling: Make sure pit form is plumb and centered accordingly. Place cut 2x4x120" temporary supports and space evenly along the length of the pit form between ledges. Use rebar stakes, two on each corner to keep form from shifting
9. Back-Filling: Using the excavated soil back-fill the outside of the form halfway. Pour approximately 8" of crushed stone on the inside of the pit and spread evenly. This will help ensure the anchoring of the pit form walls.
10. Geotextile: Use geotextile material on top of the level crushed stone. This will keep sand from filtering through the crushed stone.
11. 2nd Back Filling: Use remained of excavated dirt and back-fill the second half of the outside edges of the pit. Raise to the level needed to asphalt around the pit form for track surface (same for grass or artificial turf).
12. Fill remainder of pit with sand to the top caps. **DO NOT** fill SSC, since this is used as a storage cavity for sand when the covers are installed.

C. PFS-HS & PFS-SSC Panels

The Pit form panels is designed with a 1/2" recess for application of synthetic material. **Consult local sports surfacing company for application of synthetic material.**

D. OPERATION, CARE & SPECIAL INSTRUCTIONS:

1. When Pit Form **is** in use, covers and hardware should be removed from the pit, with exception to the SSC Cover. Make sure all hardware is retrieved after dis-assembly to prevent against accidental injury.
2. When the Pit Form **is not** in use, covers should be installed. The SSC Cover should be installed at **all** times.
3. The Pit Form Covers are designed to cover the water jump pit primarily for safety and to add extra field area for athletes. The Cover **is not** designed to withstand or support grounds equipment or vehicular traffic.

FOR TECHNICAL ASSISTANCE, CALL 1-800-523-5471