

# Portable Outfield Fence System Specifications

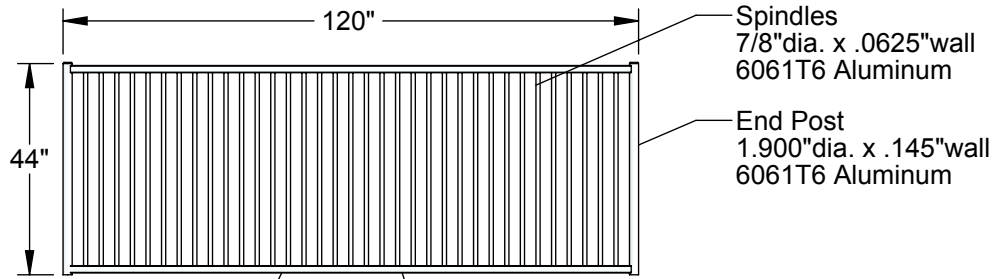

Top & Bottom Rail  
1-1/2"sq. x .109"wall  
6061T6 Aluminum

Model No. POF-PANEL  
Aluminum Outfield Fence  
-completely welded  
(38 lbs. each)

**Optional:**  
Model No. SFP-2  
Premium SafeFoam® Padding  
3/4" thick standard 8'-0" length  
Yellow vinyl-coated skin helps create a  
more visible boundary

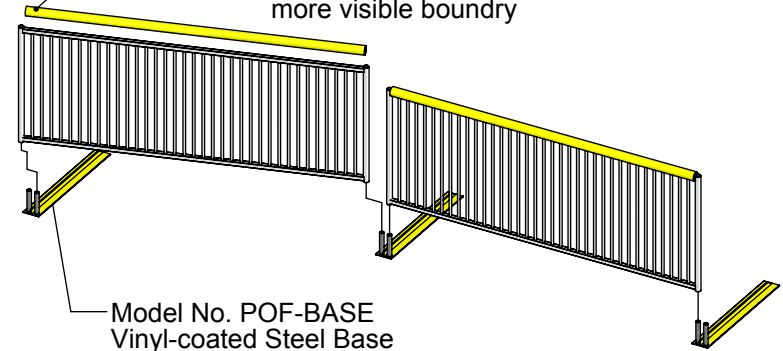

Model No. POF-BASE  
Vinyl-coated Steel Base  
-dual fence supports  
(32 lbs. each)

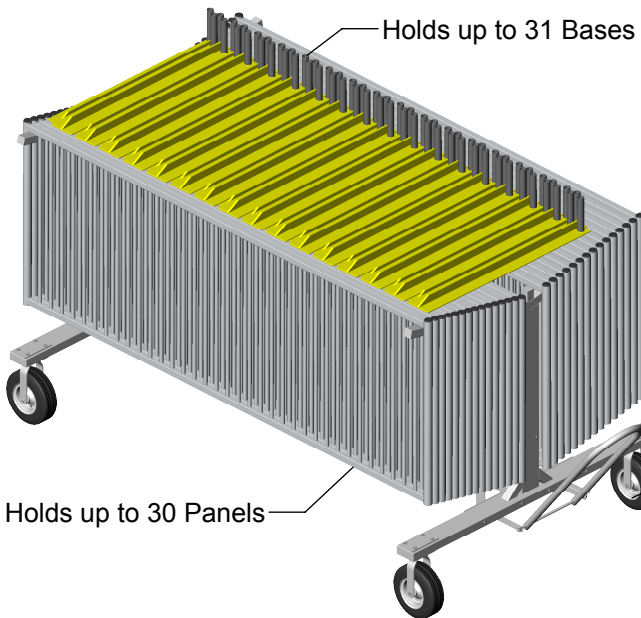

Holds up to 31 Bases

**\*OPTIONAL\***  
Model No. POF-CART  
Aluminum Outfield Fence Cart  
(Max Capacity - 2500 lbs.)

16"dia. Heavy-duty Casters  
Flat-free Foam Filled Wheels  
(Rating: 750 lbs./caster)

Portable Outfield Fence System  
sets up in minutes and sections  
can be angled in any direction  
as needed.

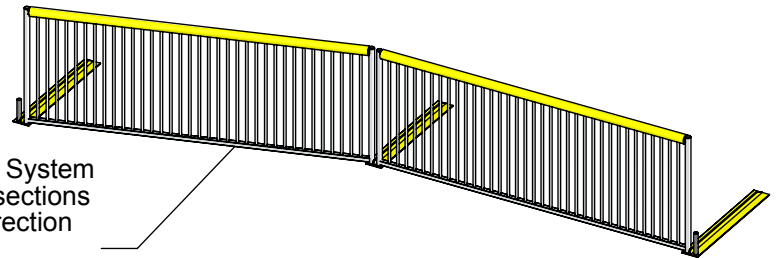

**Aluminum Athletic Equipment**  
1000 Enterprise Drive, Royersford, PA 19468  
Toll Free: (800) 523-5471 Fax: (610) 825-2378  
[www.AAEsports.com](http://www.AAEsports.com)

DESCRIPTION: <b>Portable Outfield Fence System - Specifications</b>		
NOTE: Outfield Fence Solution		
MODEL: POFS	CATEGORY: <b>CUSTOMER</b>	DATE: 4/15/14
DWN. BY: TAD	CAD FILE: Portable Outfield Fence - Specs	DWG. NO. POFS-C-001