

**AAE Model No. PTB-21B/S**  
**21' Portable Team Bench (with Backrest & Shelf)**

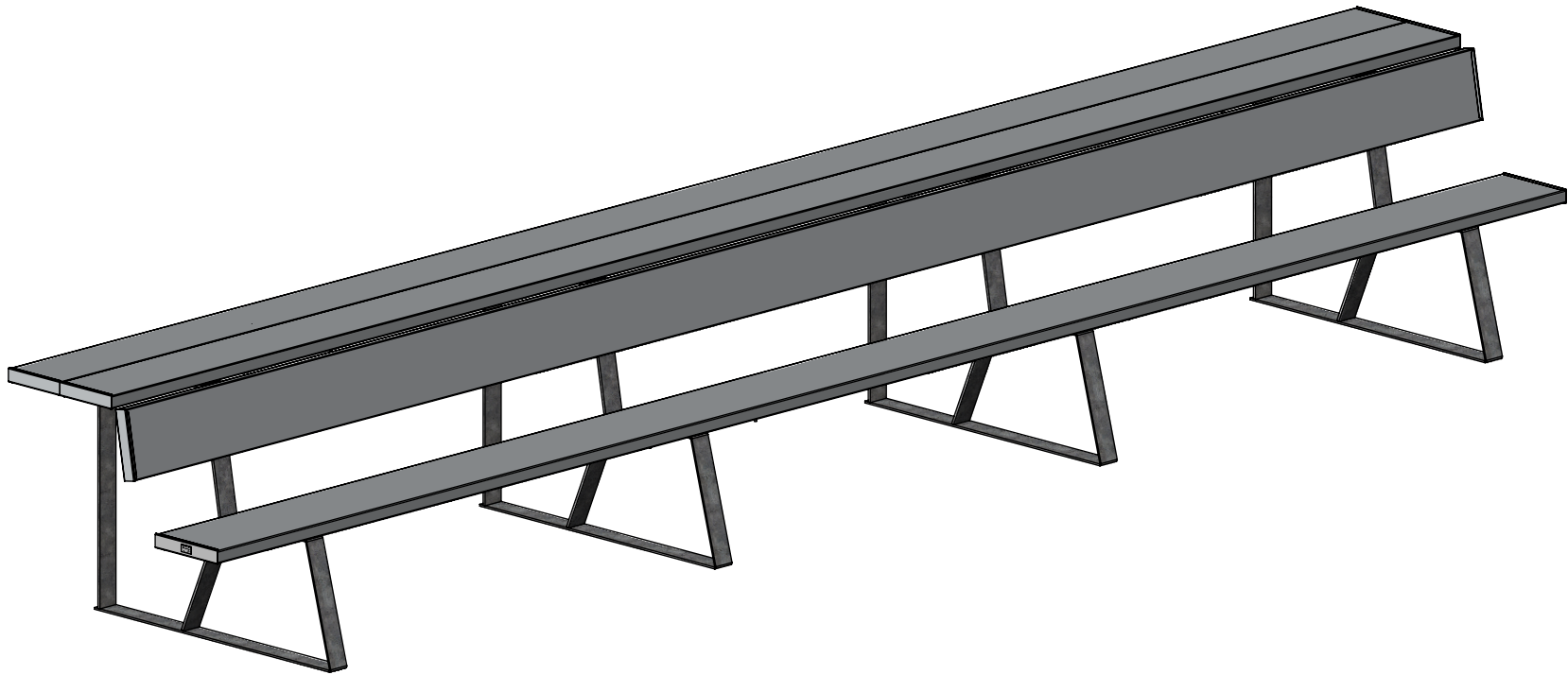

**Aluminum Athletic Equipment**  
1000 Enterprise Drive, Royersford, PA 19468  
Toll Free: (800) 523-5471 Fax: (610) 825-2378  
[www.AAEsports.com](http://www.AAEsports.com)

# PTB-21B/S - Portable Team Bench 21' (with backrest & shelf)

## Specifications

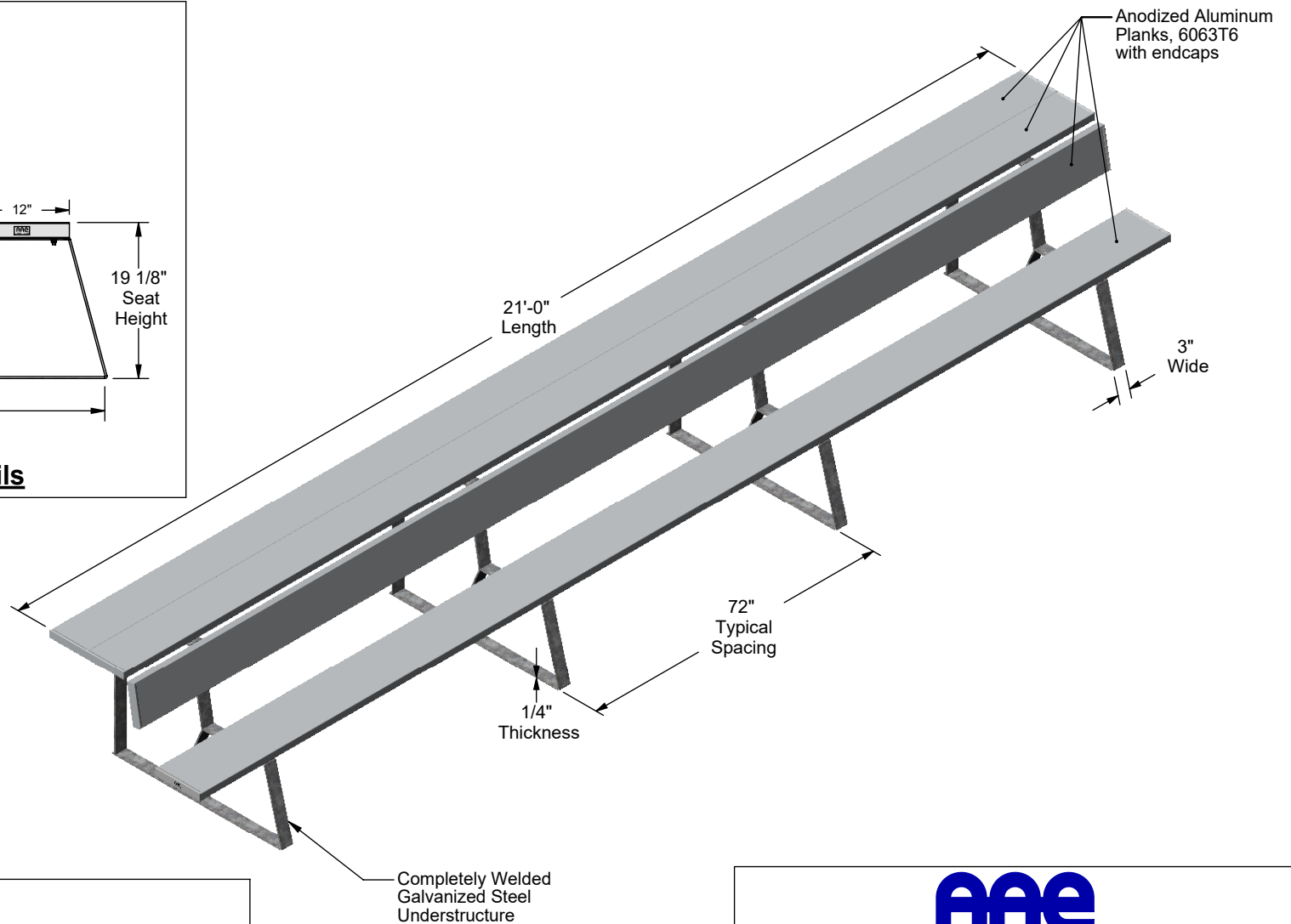
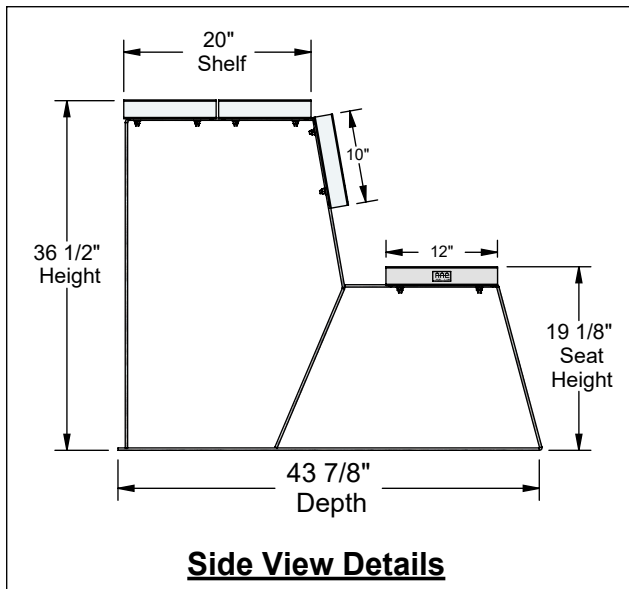

### Equipment Details

Materials: Anodized Aluminum, 6063T6  
Galvanized Steel, 1/4" x 3" HRS  
Aluminum & Stainless Steel Hardware.

Overall Weight: 365 lbs.  
Overall Size: 3' high x 4' deep x 21' long

**\*LIFETIME WARRANTY\***

 <b>Aluminum Athletic Equipment</b> 1000 Enterprise Drive, Royersford, PA 19468 Toll Free: (800) 523-5471 Fax: (610) 825-2378 <a href="http://www.AAEsports.com">www.AAEsports.com</a>		
DESCRIPTION: <b>PTB-21B/S - Specifications</b>		
NOTE: 21' with backrest and shelf		
MODEL: PTB-21B/S	CATEGORY: <b>CUSTOMER</b>	DATE: 9/29/15
DWN. BY: CED	CAD FILE: PTB-21B/S - Specs	DWG. NO. PTB-21B/S-C-001

# PTB-21B/S - 21' Team Bench (with Backrest & Shelf)

## Assembly

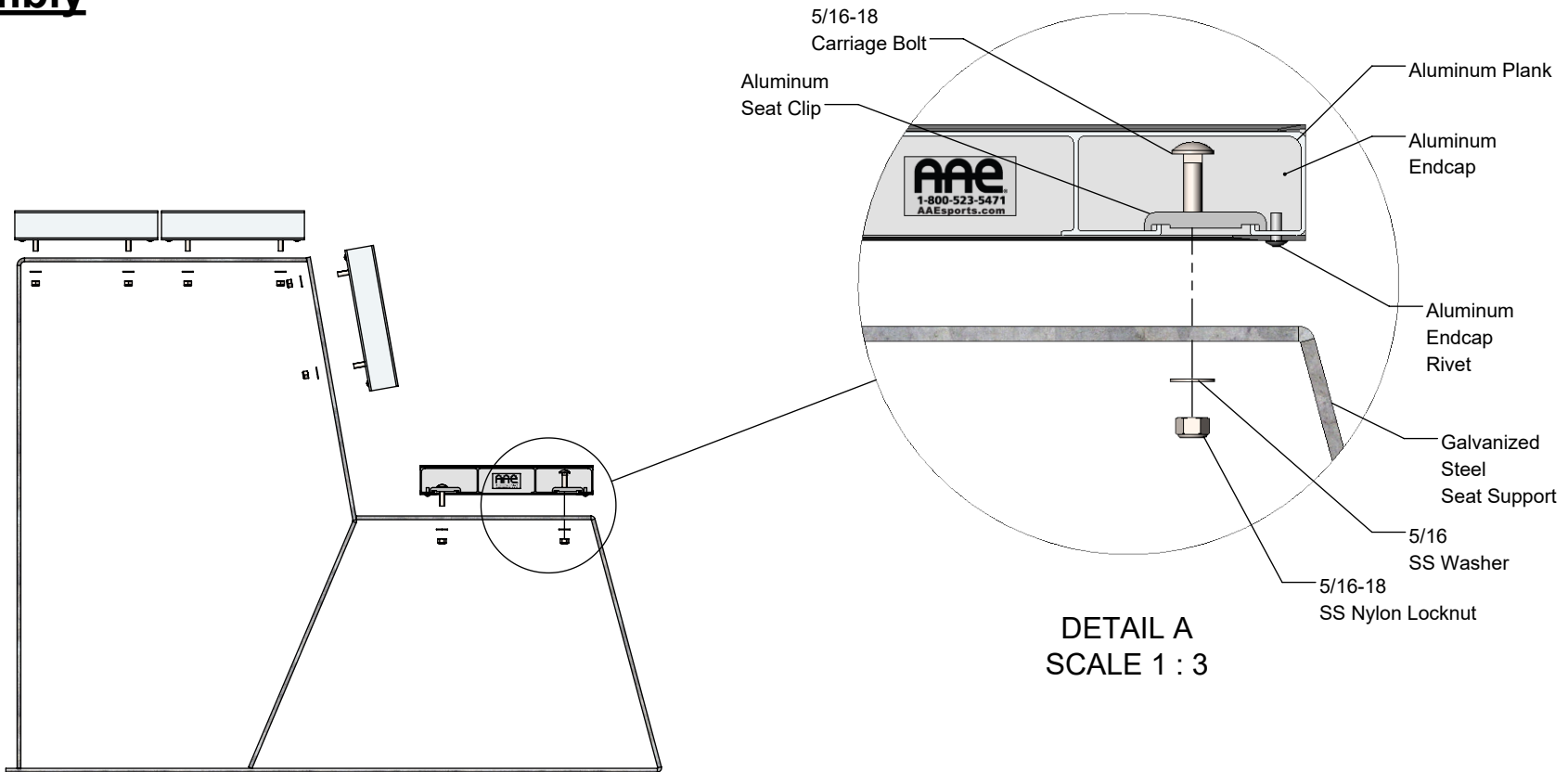

DETAIL A  
SCALE 1 : 3

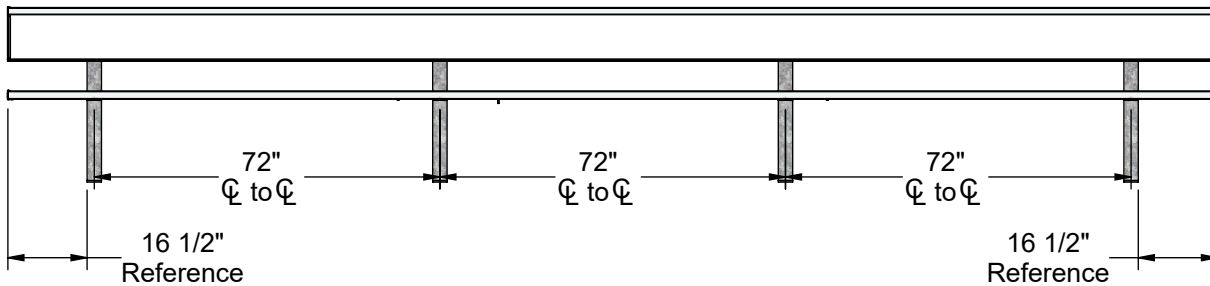

**AAE**  
Aluminum Athletic Equipment  
1000 Enterprise Drive, Royersford, PA 19468  
Toll Free: (800) 523-5471 Fax: (610) 825-2378  
www.AAEsports.com

DESCRIPTION:		
<b>PTB-21B/S - Assembly</b>		
NOTE: Layout Installation		
MODEL:	CATEGORY:	DATE:
PTB-21B/S	<b>CUSTOMER</b>	11/18/2020
DWN. BY:	CAD FILE:	DWG. NO.:
CED	PTB-21B_S - Specifications	PTB-21B/S-C-002