

PVS-NCAA

Collegiate Premier Pole Vault Standards

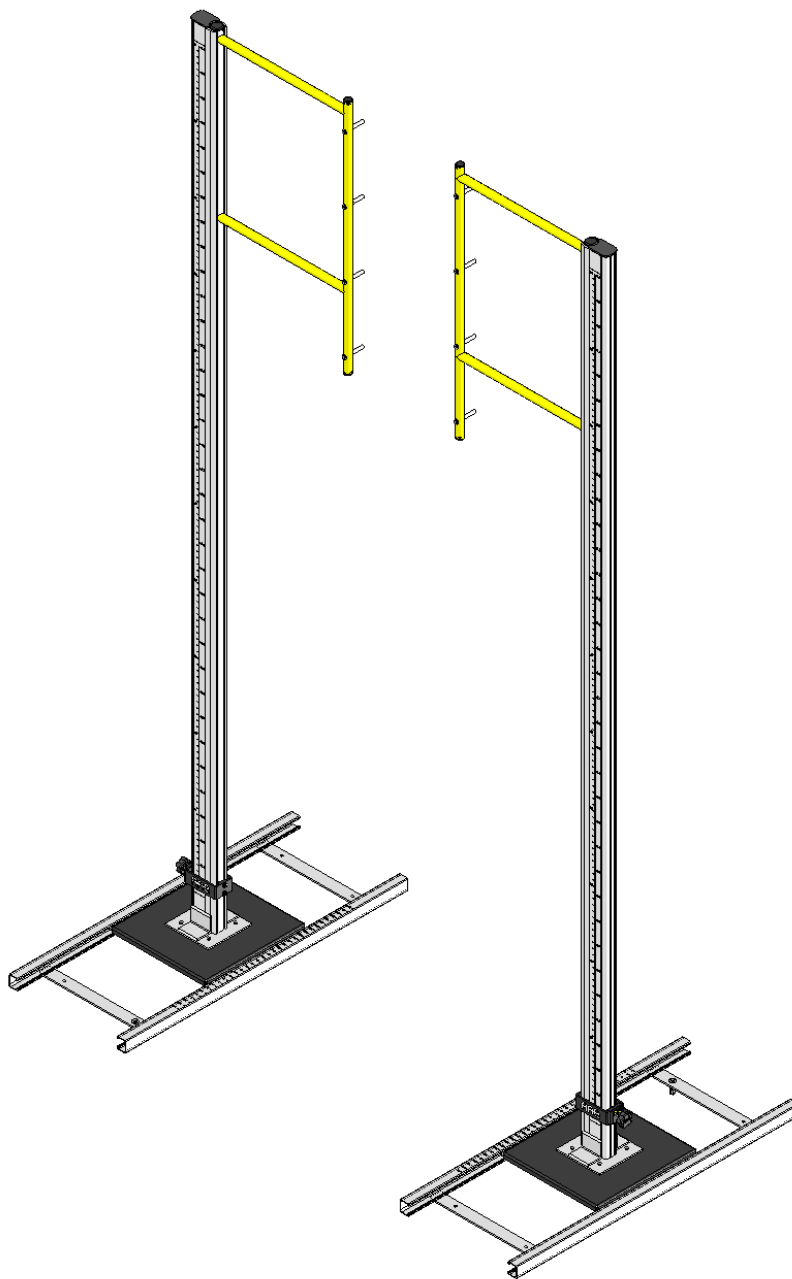

Aluminum Athletic Equipment
1000 Enterprise Drive, Royersford, PA 19468
Toll Free: (800) 523-5471 Fax: (610) 825-2378
www.myAAEworld.com

PVS-NCAA - Premier Pole Vault Standards (Collegiate)

Standard Features and Specifications

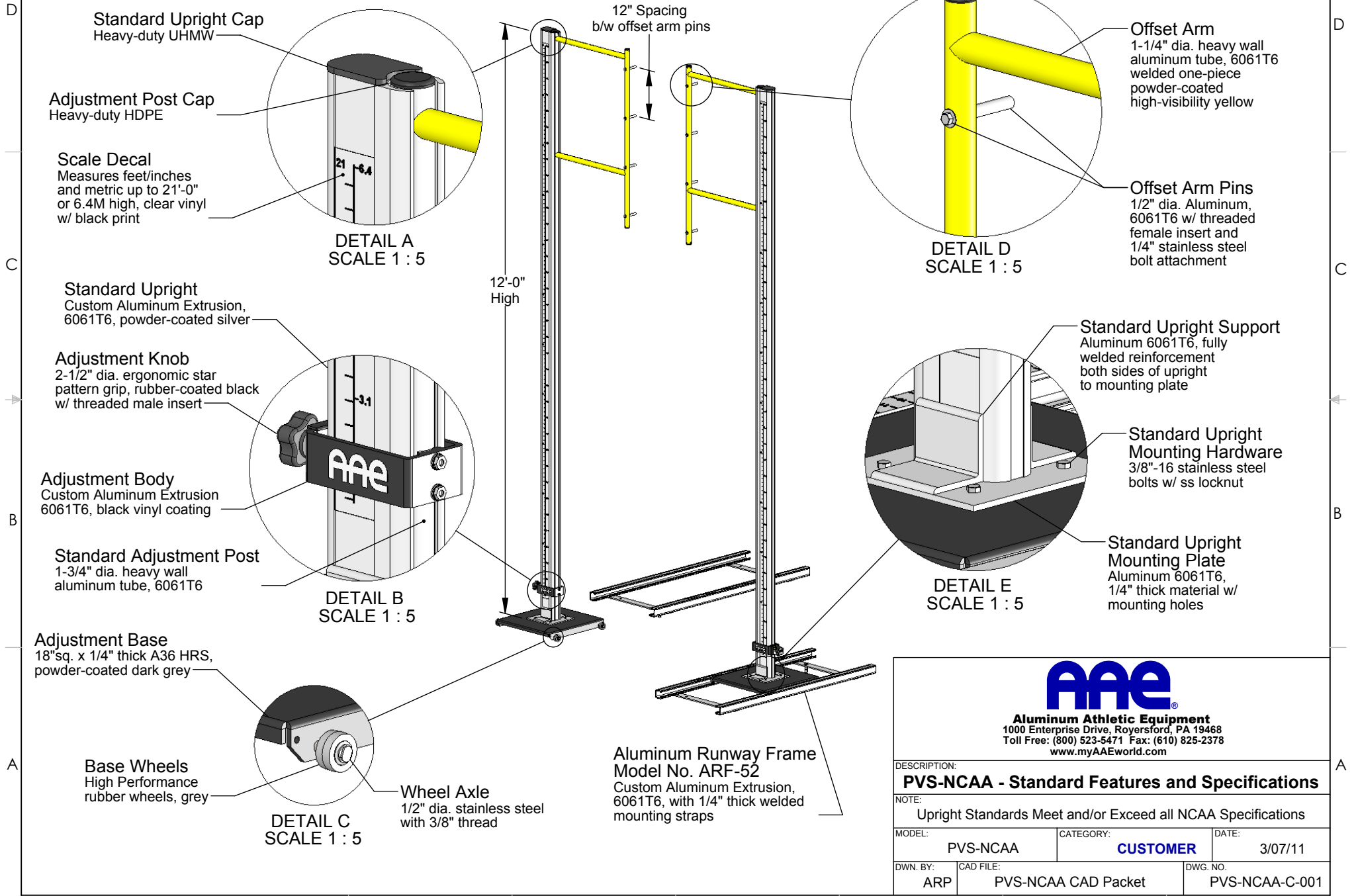

Aluminum Athletic Equipment
1000 Enterprise Drive, Royersford, PA 19468
Toll Free: (800) 523-5471 Fax: (610) 825-2378
www.myAAEworld.com

DESCRIPTION:		
PVS-NCAA - Standard Features and Specifications		
NOTE: Upright Standards Meet and/or Exceed all NCAA Specifications		
MODEL:	CATEGORY:	DATE:
PVS-NCAA	CUSTOMER	3/07/11
DWN. BY:	CAD FILE:	DWG. NO.:
ARP	PVS-NCAA CAD Packet	PVS-NCAA-C-001

PVS-NCAA - Premier Pole Vault Standards (Collegiate) Assembly

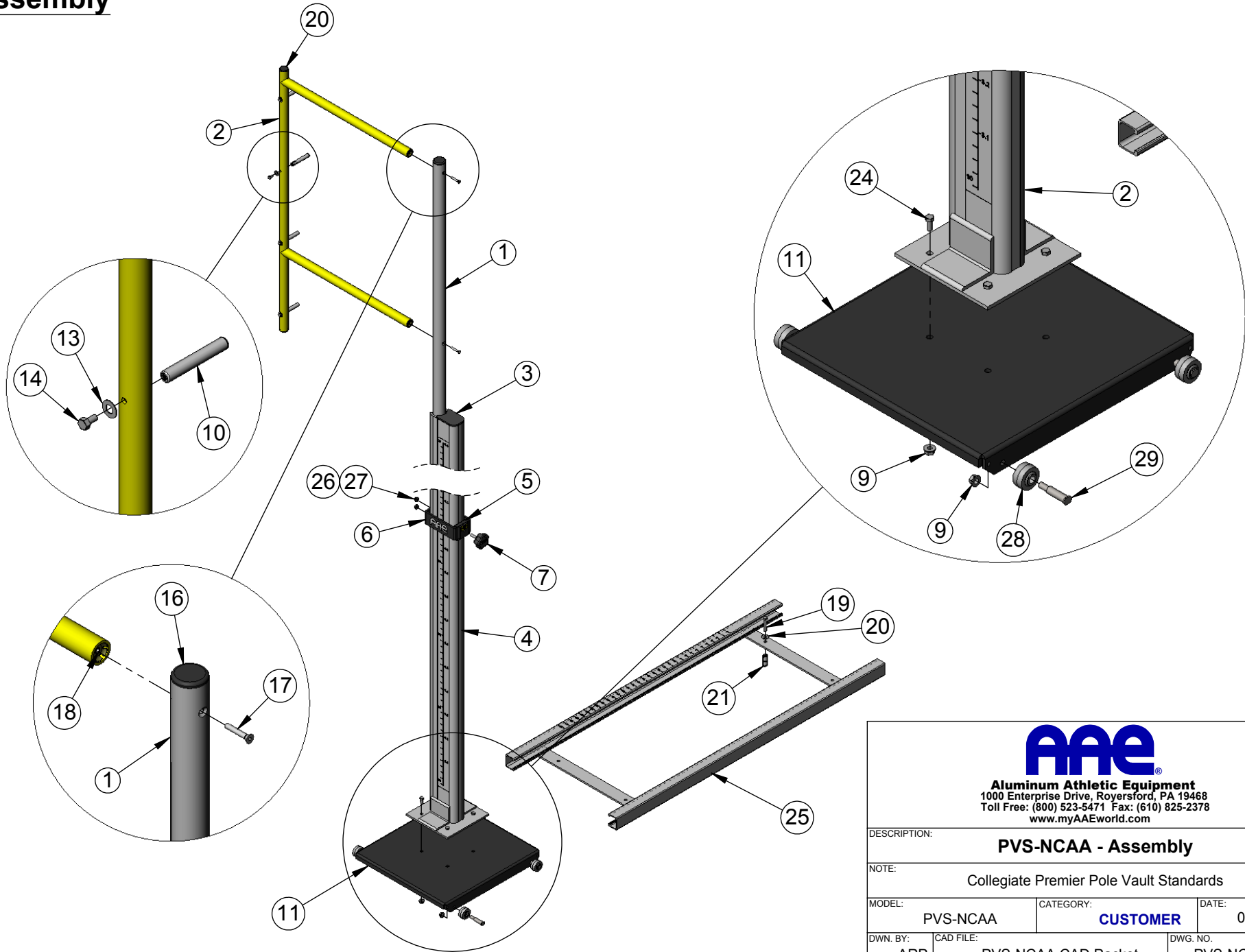

Aluminum Athletic Equipment
 1000 Enterprise Drive, Royersford, PA 19468
 Toll Free: (800) 523-5471 Fax: (610) 825-2378
www.myAAEworld.com

DESCRIPTION:		
PVS-NCAA - Assembly		
NOTE: Collegiate Premier Pole Vault Standards		
MODEL: PVS-NCAA	CATEGORY: CUSTOMER	DATE: 02/07/12
DWN. BY: ARP	CAD FILE: PVS-NCAA CAD Packet	DWG. NO. PVS-NCAA-C-002

PVS-NCAA - Premier Pole Vault Standards (Collegiate)

Plan View Layout

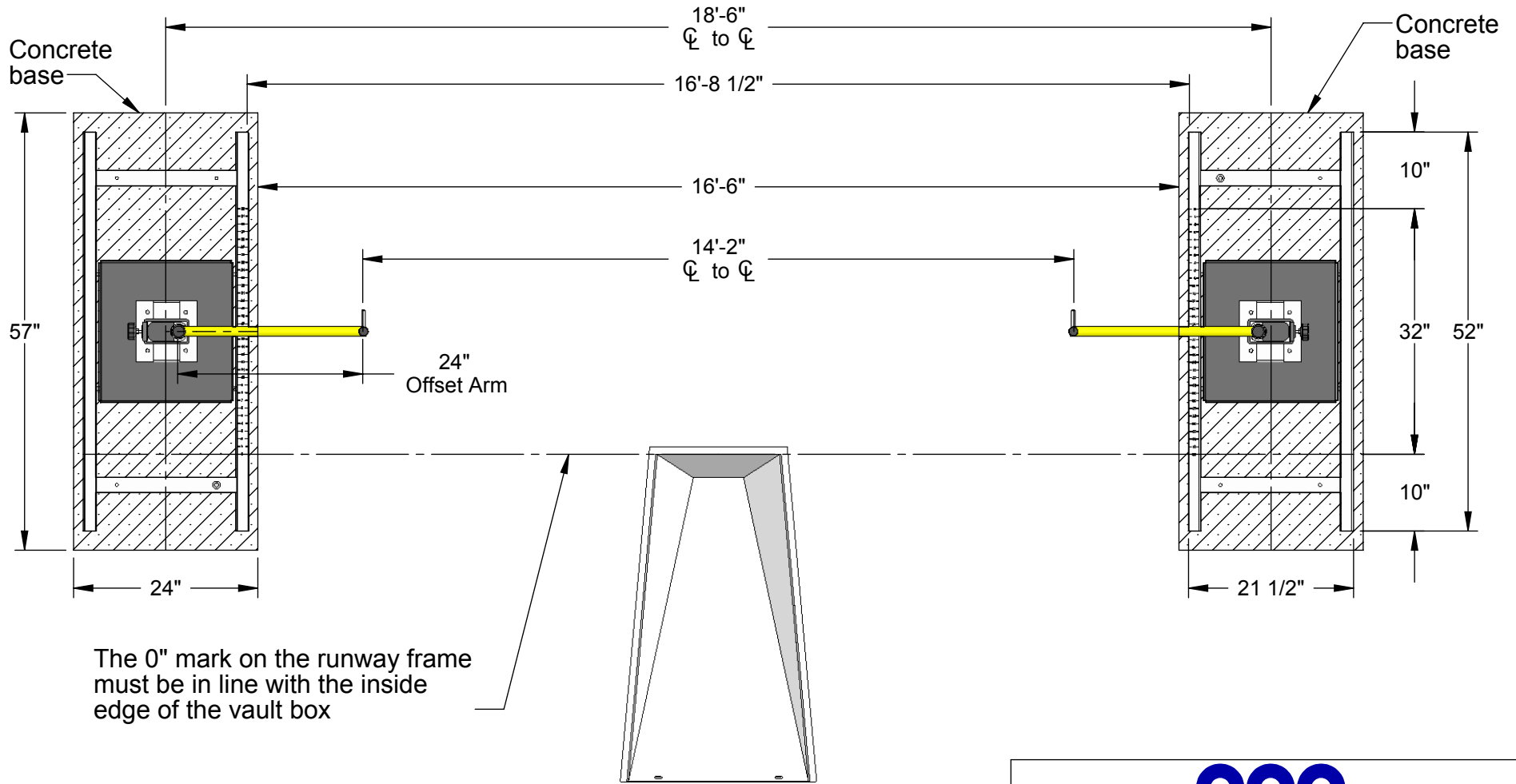

The 0" mark on the runway frame must be in line with the inside edge of the vault box

Vault Box
(Sold Separately)

Notes:

- Dimensions listed are for 21'-6" wide AAE pits only. Consult AAE for different width pits.
- Runway frame must be anchored to concrete base
- The NCAA permits only 13 5/8" adjustment away from the vaulter (towards the back of the pit)



Aluminum Athletic Equipment
1000 Enterprise Drive, Royersford, PA 19468
Toll Free: (800) 523-5471 Fax: (610) 825-2378
www.myAAEworld.com

DESCRIPTION:		
PVS-NCAA - Plan View Layout		
NOTE: Collegiate Premier Pole Vault Standards		
MODEL:	CATEGORY:	DATE:
PVS-NCAA	CUSTOMER	02/07/12
DWN. BY:	CAD FILE:	DWG. NO.:
ARP	PVS-NCAA CAD Packet	PVS-NCAA-C-003

**PVS-NCAA
NCAA PREMIER POLE VAULT STANDARD
PARTS LIST**

Pt.#	Item	Description	Qty.
1	Inner Tube	1-3/4" dia. x .100 wall x 144" lg. 6061T6 aluminum tube	2
2	Offset Arm	1-1/4" x .125 wall x 22-1/2" X 24" 6061T6 Aluminum stay, "U" shape	2
3	End Cap	2-1/2" x 3" x 1/4" cast aluminum end cap	2
4	Outer Tube	2" x 5" x .150" custom aluminum extrusion, 6063T6, 12'-0" lg.	2
5	H-pad	Aluminum "H" adjustment pad, cast	2
6	Slider	Aluminum rectangular adjustment body, cast	2
7	Knob	1-7/8" dia. x 3/8"-16 x 1" adjustment knob, 922 series, ribbed	2
9	Nut	3/8"-16 nylon-insert lock nut, SS	16
10	Crossbar Pin	1/2" dia. x 4-1/2" lg. aluminum rod, 1/4"-20 tapped end	8
11	Base	Steel base	2
13	Washer	1/4"-20 washer, SS	2
14	Bolt	1/4"-20 x 1/2" hex bolt, SS	4
15	Loop	Velcro Loop, adhesive back, 1" x 5"	4
16	Cap	Plastic cap, Caplug #17-S	2
17	Bolt	1/4"-20 x 2-1/2" socket cap screw, SS	4
18	Connector	1-1/4" metal tube connector, 1/4"-20, 16-18 gage	4
19	Bolt	3/8"-16 x 2" steel hex bolt, SS	8
20	Washer	3/8" flat washer, SS	8
21	Concrete Anchor	3/8"-16 x 2" Double expansion shield	8
24	Bolt	3/8"-16 x 1" steel hex bolt, SS	
25	Runway Frame	Welded aluminum runway frame, 22-1/2" wide x 52" lg., w/ decal	2
26	Bolt	5/16"-18 x 3/4" hex bolt, SS	4
27	Nut	5/16"-18 wiz-lock nut, SS	4
28	Wheel	1 5/8" High performance rubber wheel	8
29	Axel Bolt	Machined bolt, 1/2" dia. x 1 1/2" unthreaded axel and 3/8" dia. x 3/4" threaded end; accepts 1/2" open wrench or adjustable wrench for tightening	8

Note: Starting in 2011, the Base Glider Assembly (Item Nos. 22, 23, & 24) has been replaced with the Roller Wheel Assembly (Item Nos. 9, 28, & 29). The Roller Wheel Assembly can be purchased to replace old Base Glider Assemblies

FOR TECHNICAL ASSISTANCE, CALL 1-800-523-5471

K:\AAE Data\Product Instructions & Parts Lists\PVS-NCAA\PVS-NCAA Parts List.doc
Copyright © 2011 Aluminum Athletic Equipment Co.

PVS-NCAA

NCAA PREMIER POLE VAULT STANDARD

INSTALLATION AND OPERATION INSTRUCTIONS

Please note: These instructions are for 21'-6" wide AAE pits only. Please consult AAE, or make the necessary adjustments, for different width pits.

****2004 Rule change concerning movement of the Standards.**

Minimum = 18" Maximum = 31-1/2" Travel = 13-1/2"

INSTALLATION: Refer to Drawing No. PVS-NCAA-C-003 (Concrete Pads for Runway Frames)

1. Locate proper location of concrete pads to be poured that will anchor the PVS-NCAA runway frames (Item No. 25).
2. Dig two holes approximately 30" x 66" x 6" deep and 16'-6" apart (18'-6" on center) (**Consult local building codes for concrete depth and drainage requirements**).
3. Make (2) wooden concrete forms 24" x 57" (**inside dimensions**) around the openings. Make the forms level and flush with the ground. Pour the concrete into the forms, making sure the concrete is level with the ground.
4. After the concrete has hardened, locate runway frames (Item No. 25) in their proper location: 16'-8 1/2" apart (18'-6" on center), centered on each pad. Runway frames should have the "0" mark in line with the top inside edge of the vault box (**inside edge closest to the rear of the landing pit**). Once proper location has been established, mark hole locations for fixing runway frames to the pads.
5. Remove frames. Using a 3/4" **Masonry Drill Bit**, drill a hole 2" deep. Using a hammer, tap 3/8"-16 x 2" Double Expansion Shield (Item No. 21) in with **threaded side down**, flush with concrete surface.

ASSEMBLY:

1. Bolt runway frames to concrete pads using 3/8"-16 x 2" hex bolts (Item No. 19) and 3/8" flat washers (Item No. 20). **Note: Each runway frame must be bolted into the concrete in all 4 bolting locations.** Re-check all bolts for tightness.
2. Attach four (4) roller wheels (Item No. 28) to base (Item No. 11) using machined axel bolts and 3/8"-16 serrated hex nuts (Item Nos. 29 & 9). **Refer to Drawing No. PVS-NCAA-C-002.** Repeat procedure for the other base.
3. Attach offset arm (Item No. 2), to Inner tube (Item No. 1) using 1/4"-20 x 1-1/2" socket cap screws (Item No. 17). Repeat procedures for other upright.
4. Attach crossbar pins (Item No. 10) to offset arms (Item No. 2) using 1/4"-20 x 1/2" hex bolts (Item No. 14) and 1/4" washers (Item No. 13). There are 4 crossbar pins for each offset arm.
5. Attach completed main upright assembly to base (Item No. 11) using 3/8"-16 x 1" hex bolts and 3/8"-16 serrated hex nuts (Item No. 24 & 9). Repeat

**PVS-NCAA
NCAA PREMIER POLE VAULT STANDARD
INSTALLATION AND OPERATION INSTRUCTIONS**

procedure for other upright & base.

6. Slide completed units into their respective frames. Offset arms should face **towards** the center of the pit with the adjustment knob on the outside of the pit and the crossbar pins pointing away from the runway.

OPERATION:

1. The PVS-NCAA Premier Pole Vault Standard is designed to measure jumps from 7'-0" - 21'-0". The lowest reading on the adjustment scale is 10'-0". The 10'-0" reading is used with the crossbar located on the top crossbar support pin. To obtain a 7'-0" measurement, move the crossbar down to the lowest crossbar pin position. Likewise, a 21'-0" reading would be taken when the reading on the scale was 21'-0" and the crossbar was on the top crossbar pin.
2. Pole Vault standard may be adjusted manually by loosening adjusting knob (Item No. 7) and raising or lowering the upright to the desired height. Pole Vault standard may also be adjusted in a 1'-0" increments by moving crossbar from pin to pin. (Crossbar pins are 12" apart.)

CARE AND SPECIAL INSTRUCTIONS:

1. At the end of the season, as well as after each event (dependent upon the risk of vandalism or injury), the upright assemblies should be removed and the runway frames unbolted and removed for storage. Frequent storage and proper care of the PVS-NCAA will greatly improve the life and functionality of the unit.
2. While the PVS-NCAA is in use, the runway frame **must be bolted** into the concrete for safety of the participants as well as for proper operation.
3. Properly installed, the PVS-NCAA can be adjusted laterally from 0" – 32" (with 0" being the inside edge of the vault box) away from the vaulter. The 2004 NCAA Men's & Women's Rule Book states the following:

RULE 6-6/FIELD EVENTS

SECTION 6. The Pole Vault

Moving Uprights

ARTICLE 6. Competitors may have the uprights moved toward the landing area not less than 45 centimeters (18 in.) and not more than 80 centimeters (31.5 in.) from the extension of the inside edge of the top of the box.

FOR TECHNICAL ASSISTANCE, CALL 1-800-523-5471

K:\AAE Data\Product Instructions & Parts Lists\PVS-NCAA\PVS-NCAA Assembly Instructions.doc
Copyright © 2011 Aluminum Athletic Equipment Co.