

# AAE Model No. SHJ-26/28

## Super High Jump Pad

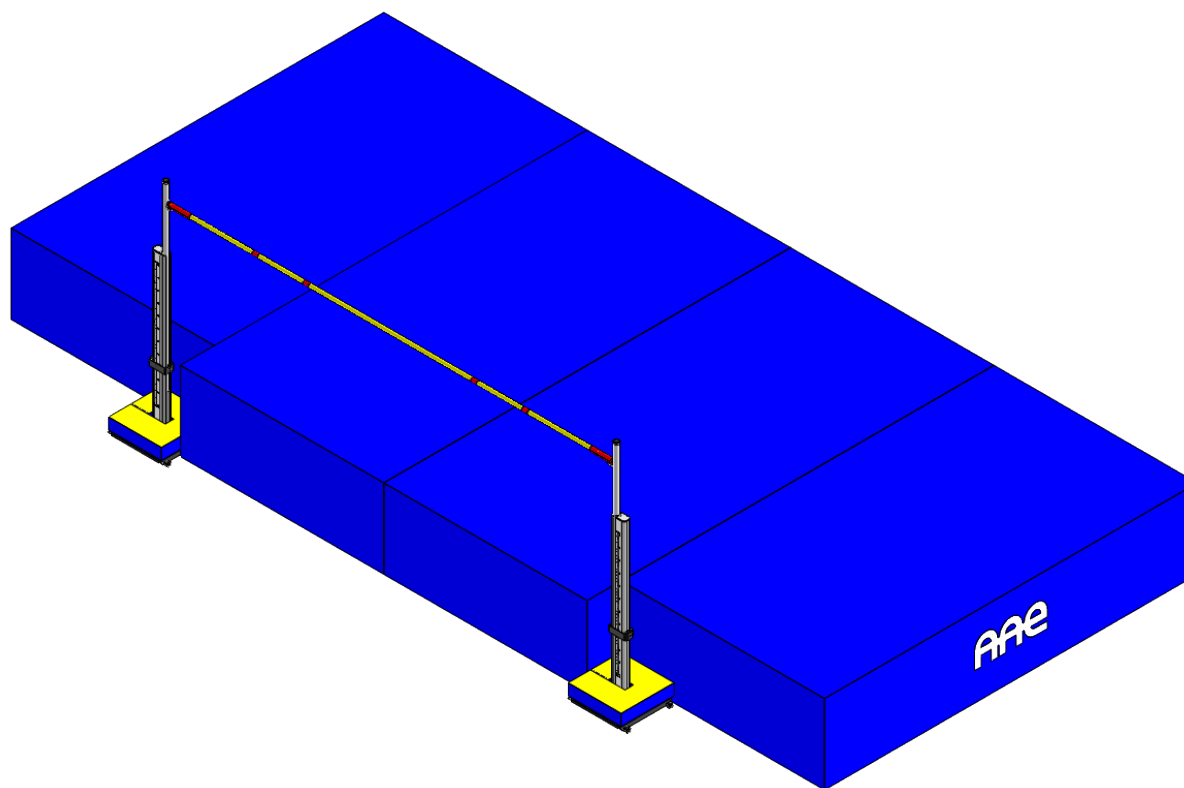

**AAE**

**Aluminum Athletic Equipment**  
1000 Enterprise Drive, Royersford, PA 19468  
Toll Free: (800) 523-5471 Fax: (610) 825-2378  
[www.AAEsports.com](http://www.AAEsports.com)

**SHJ-26/28**  
**Specifications**  
**Blue Breather Cover**  
**or Top Pad**

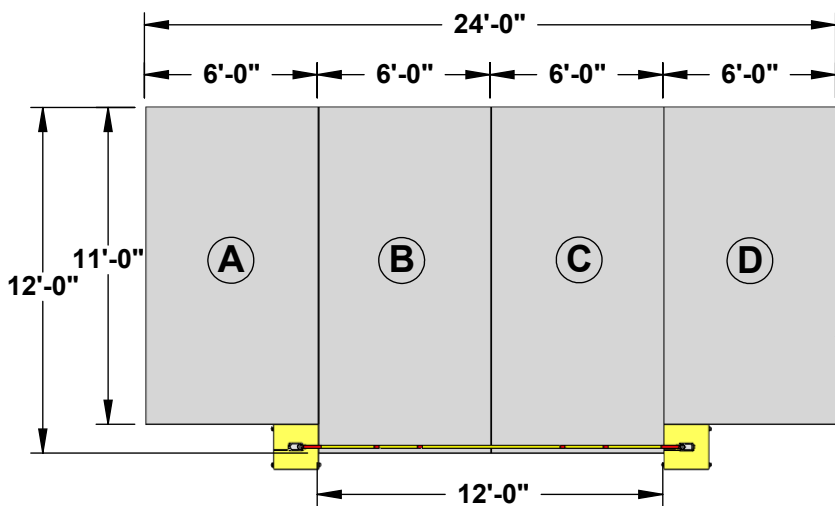
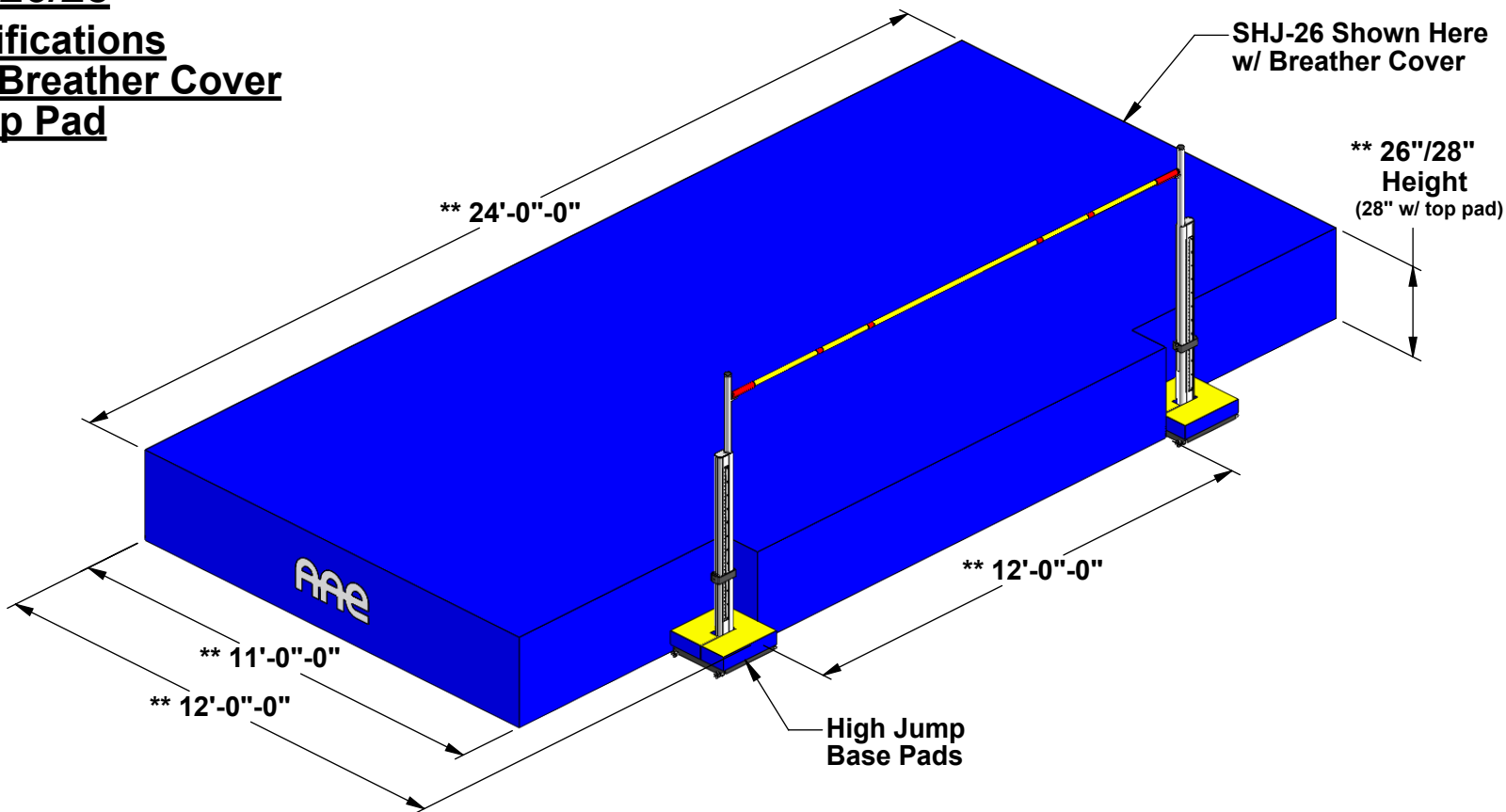

SHJ-26 Shown Here w/o Breather Cover (in 4 sections)

**\*\* Meets & Exceeds National Federation of State High School Associations & The National Collegiate Athletic Association's Ruling**



**Aluminum Athletic Equipment**  
 1000 Enterprise Drive, Royersford, PA 19468  
 Toll Free: (800) 523-5471 Fax: (610) 825-2378  
[www.AAEsports.com](http://www.AAEsports.com)

|   |                                  |                            |
|---|----------------------------------|----------------------------|
| DESCRIPTION   |                                  |                            |
| <b>SHJ-26/28 Super High Jump Pad Specifications</b>     |                                  |                            |
| NOTE: Meets/Exceeds High School and NCAA Specifications |                                  |                            |
| MODEL: SHJ-26/28  | CATEGORY: CUSTOMER               | DATE: 2/28/02              |
| DRAWN BY: TAD   | CAD FILE: SHJ-26-28 Specs (Blue) | DWG. NO. SHJ-26/28-C-100BI |

**SHJ-26/28**  
**Specifications**  
**Yellow Breather Cover**  
**or Top Pad**

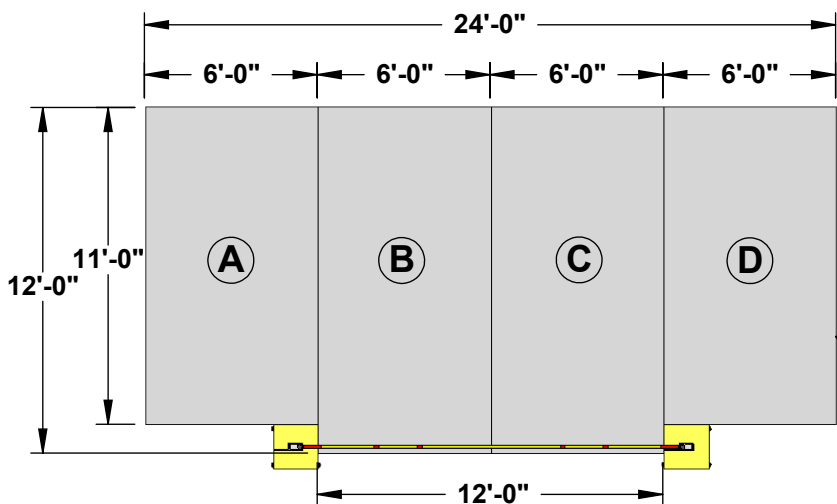
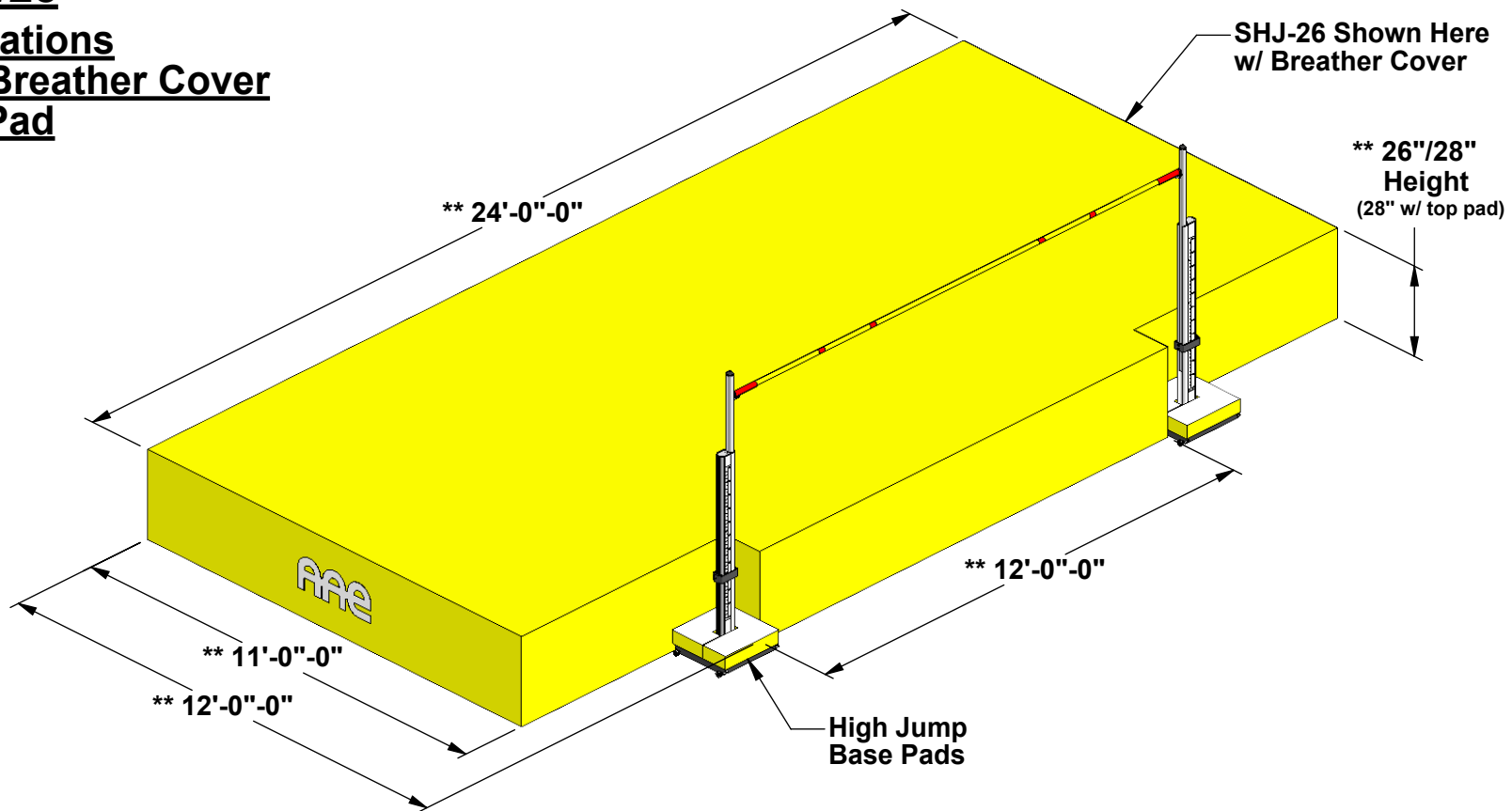

**\*\* Meets & Exceeds National Federation of State High School Associations & The National Collegiate Athletic Association's Ruling**



**Aluminum Athletic Equipment**  
 1000 Enterprise Drive, Royersford, PA 19468  
 Toll Free: (800) 523-5471 Fax: (610) 825-2378  
[www.AAEsports.com](http://www.AAEsports.com)

|   |                                    |                            |
|---|------------------------------------|----------------------------|
| DESCRIPTION   |                                    |                            |
| <b>SHJ-26/28 Super High Jump Pad Specifications</b>     |                                    |                            |
| NOTE: Meets/Exceeds High School and NCAA Specifications |                                    |                            |
| MODEL: SHJ-26/28  | CATEGORY: CUSTOMER                 | DATE: 2/28/02              |
| DRAWN BY: TAD   | CAD FILE: SHJ-26-28 Specs (Yellow) | DWG. NO. SHJ-26/28-C-100Yw |

**SHJ-26/28**  
**Specifications**  
**Red Breather Cover**  
**or Top Pad**

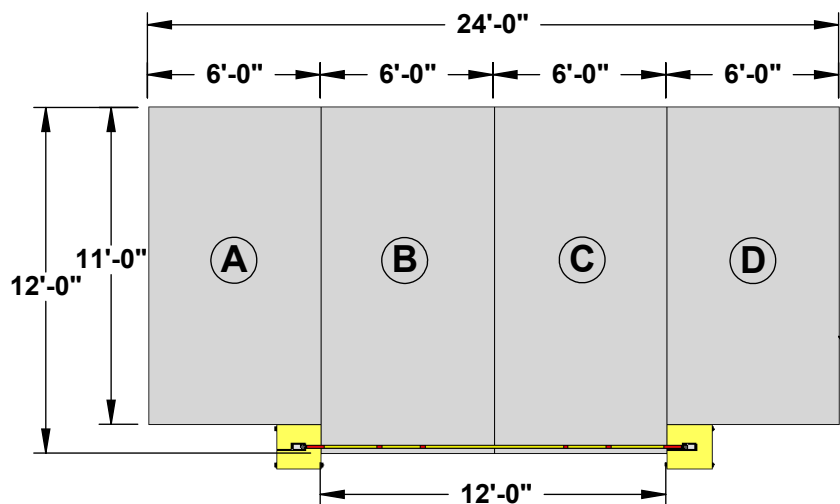
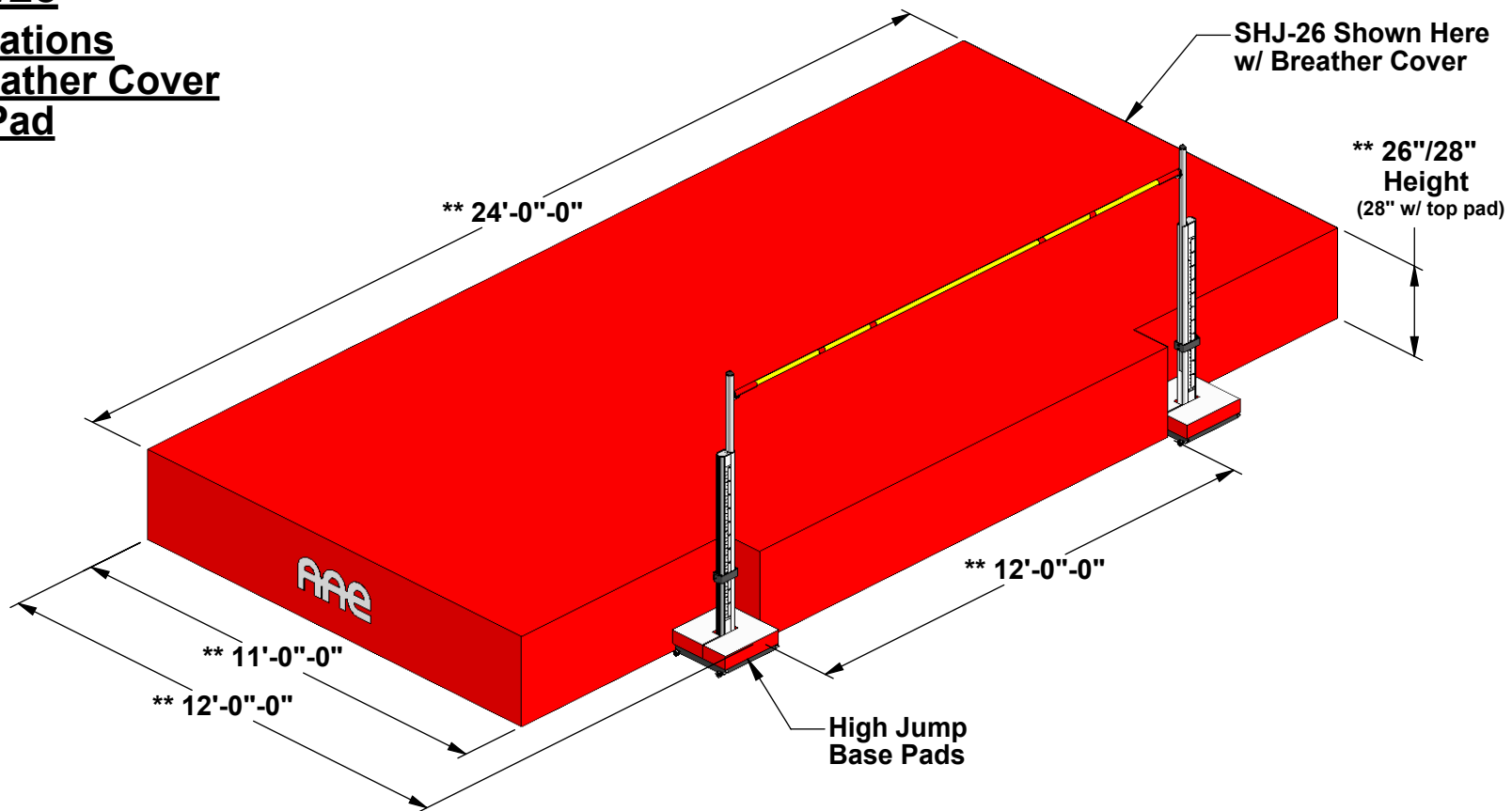

**\*\* Meets & Exceeds National Federation of State High School Associations & The National Collegiate Athletic Association's Ruling**



**Aluminum Athletic Equipment**  
 1000 Enterprise Drive, Royersford, PA 19468  
 Toll Free: (800) 523-5471 Fax: (610) 825-2378  
[www.AAEsports.com](http://www.AAEsports.com)

|   |                       |                   |
|---|-----------------------|-------------------|
| DESCRIPTION   |                       |                   |
| <b>SHJ-26/28 Super High Jump Pad Specifications</b>     |                       |                   |
| NOTE: Meets/Exceeds High School and NCAA Specifications |                       |                   |
| MODEL:  | CATEGORY:             | DATE:             |
| SHJ-26/28   | <b>CUSTOMER</b>       | 2/28/02           |
| DRAWN BY:   | CAD FILE:             | DWG. NO.:         |
| TAD   | SHJ-26-28 Specs (Red) | SHJ-26/28-C-100Rd |

**SHJ-26/28**  
**Specifications**  
**Purple Breather Cover**  
**or Top Pad**

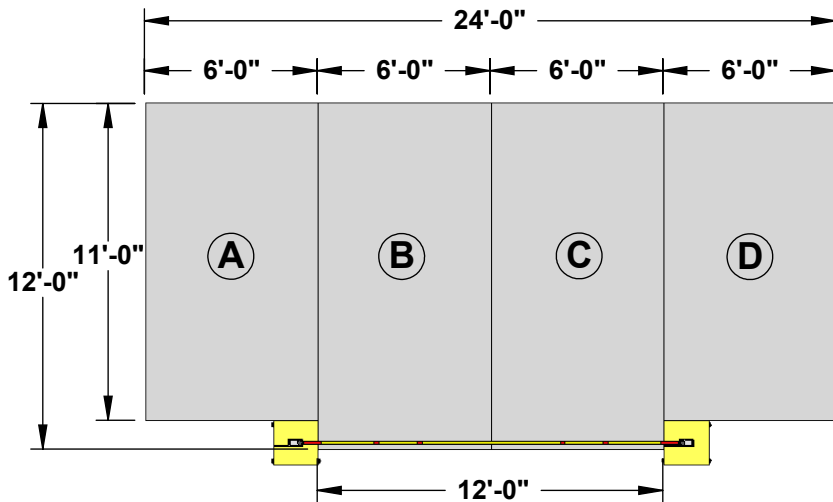
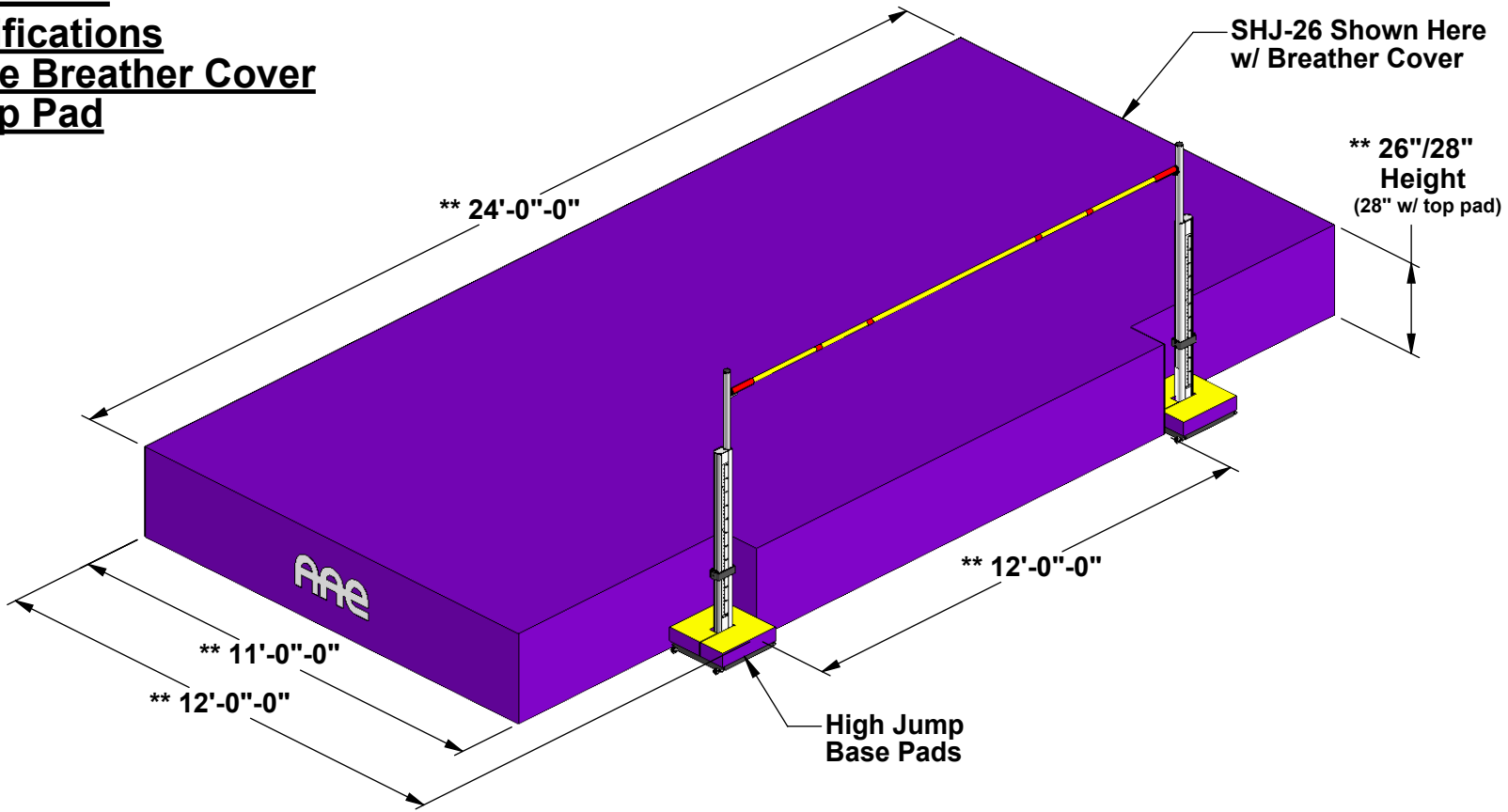

**SHJ-26 Shown Here w/o Breather Cover (in 4 sections)**

**\*\* Meets & Exceeds National Federation of State High School Associations & The National Collegiate Athletic Association's Ruling**



**Aluminum Athletic Equipment**  
 1000 Enterprise Drive, Royersford, PA 19468  
 Toll Free: (800) 523-5471 Fax: (610) 825-2378  
[www.AAEsports.com](http://www.AAEsports.com)

|   |                          |                   |               |
|---|--------------------------|-------------------|---------------|
| DESCRIPTION   |                          |                   |               |
| <b>SHJ-26/28 Super High Jump Pad Specifications</b>     |                          |                   |               |
| NOTE: Meets/Exceeds High School and NCAA Specifications |                          |                   |               |
| MODEL:  | SHJ-26/28                | CATEGORY:         | CUSTOMER      |
|   |                          |                   | DATE: 2/28/02 |
| DRAWN BY:   | CAD FILE:                | DWG. NO.          |               |
| TAD   | SHJ-26-28 Specs (Purple) | SHJ-26/28-C-100Pr |               |

**SHJ-26/28**  
**Specifications**  
**Orange Breather Cover**  
**or Top Pad**

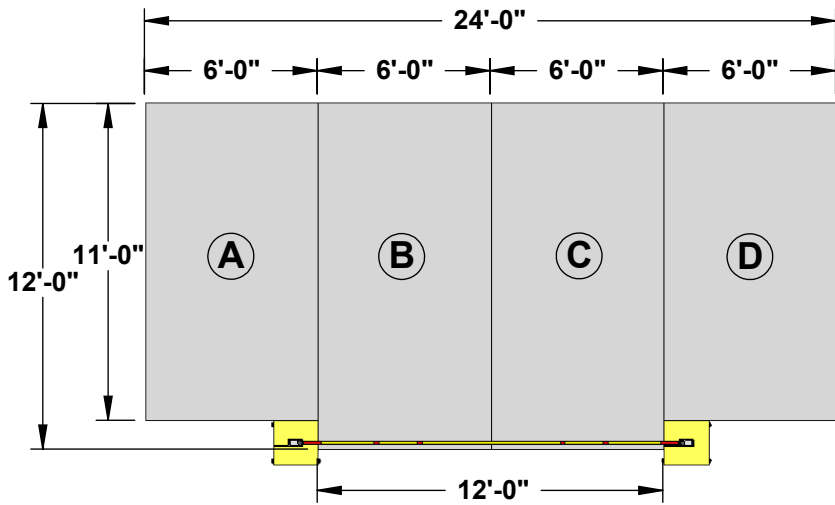
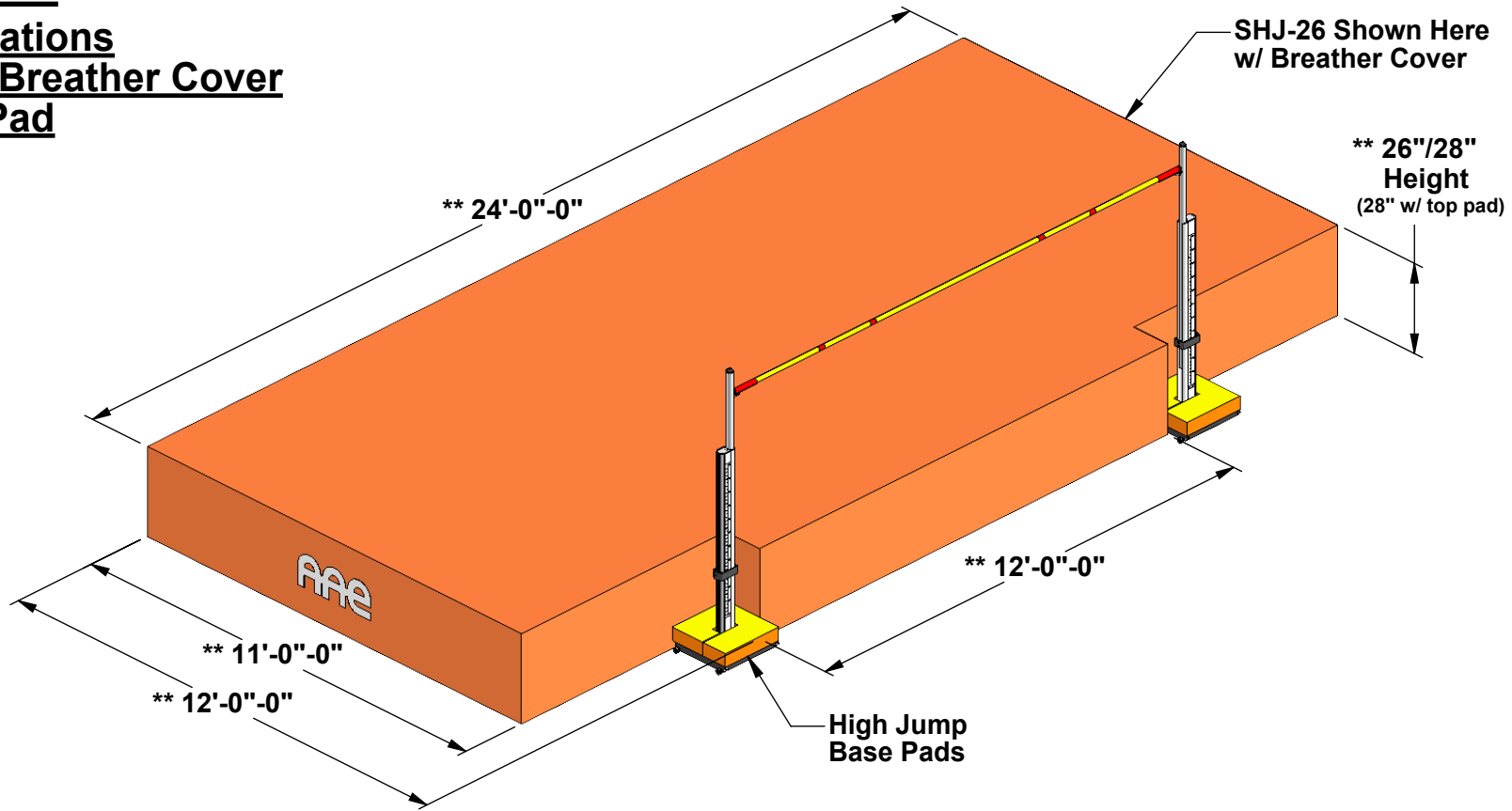

**\*\* Meets & Exceeds National Federation of State High School Associations & The National Collegiate Athletic Association's Ruling**



**Aluminum Athletic Equipment**  
 1000 Enterprise Drive, Royersford, PA 19468  
 Toll Free: (800) 523-5471 Fax: (610) 825-2378  
[www.AAEsports.com](http://www.AAEsports.com)

|   |                                    |                            |
|---|------------------------------------|----------------------------|
| DESCRIPTION   |                                    |                            |
| <b>SHJ-26/28 Super High Jump Pad Specifications</b>     |                                    |                            |
| NOTE: Meets/Exceeds High School and NCAA Specifications |                                    |                            |
| MODEL: SHJ-26/28  | CATEGORY: CUSTOMER                 | DATE: 2/28/02              |
| DRAWN BY: TAD   | CAD FILE: SHJ-26-28 Specs (Orange) | DWG. NO. SHJ-26/28-C-100Or |

**SHJ-26/28**  
**Specifications**  
**Maroon Breather Cover**  
**or Top Pad**

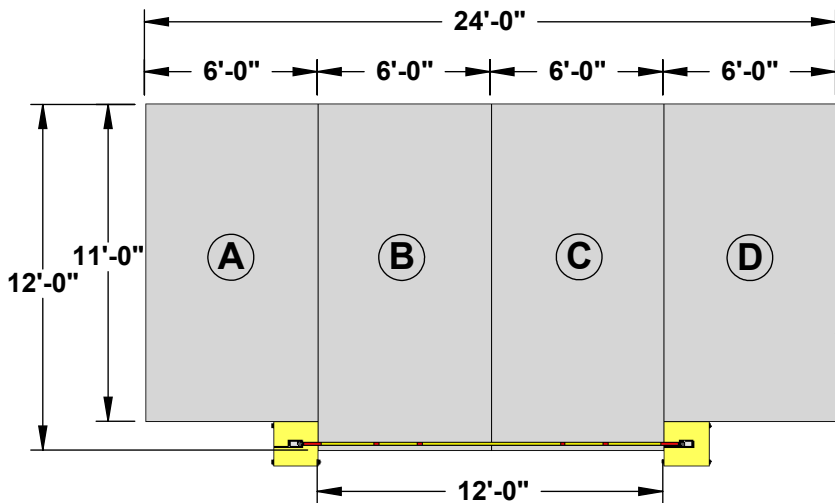
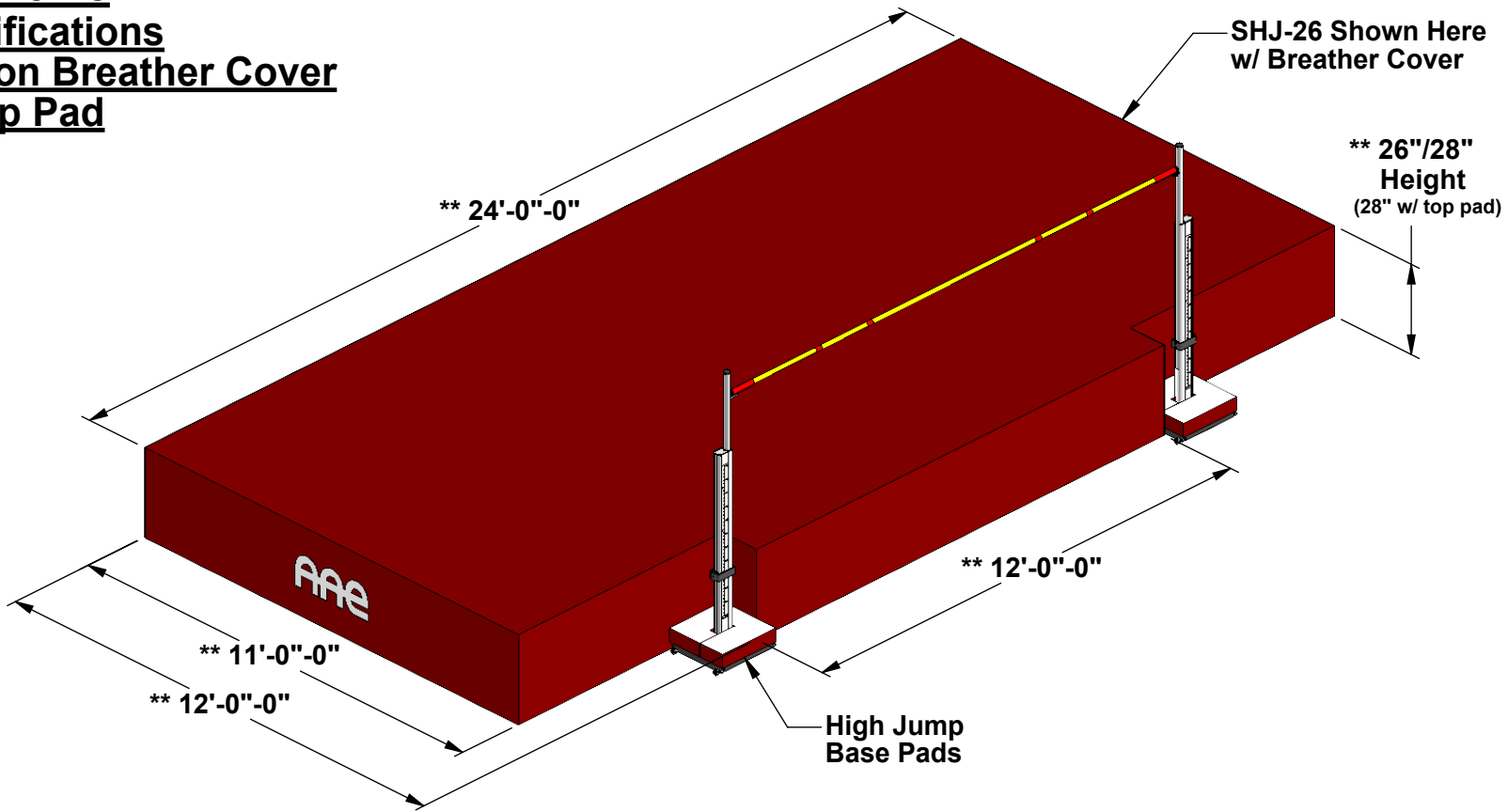

**\*\* Meets & Exceeds National Federation of State High School Associations & The National Collegiate Athletic Association's Ruling**



**Aluminum Athletic Equipment**  
 1000 Enterprise Drive, Royersford, PA 19468  
 Toll Free: (800) 523-5471 Fax: (610) 825-2378  
[www.AAEsports.com](http://www.AAEsports.com)

|   |                                    |                            |
|---|------------------------------------|----------------------------|
| DESCRIPTION   |                                    |                            |
| <b>SHJ-26/28 Super High Jump Pad Specifications</b>     |                                    |                            |
| NOTE: Meets/Exceeds High School and NCAA Specifications |                                    |                            |
| MODEL: SHJ-26/28  | CATEGORY: CUSTOMER                 | DATE: 2/28/02              |
| DRAWN BY: TAD   | CAD FILE: SHJ-26-28 Specs (Maroon) | DWG. NO. SHJ-26/28-C-100Mn |

**SHJ-26/28**  
**Specifications**  
**Green Breather Cover**  
**or Top Pad**

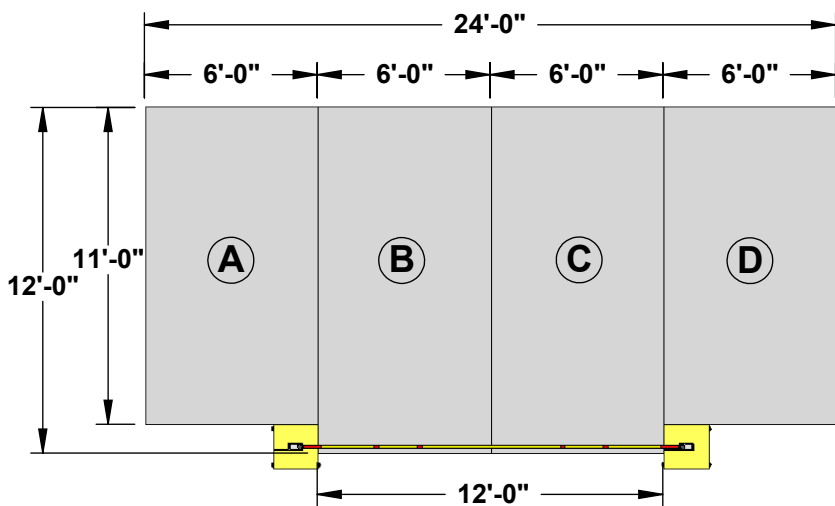
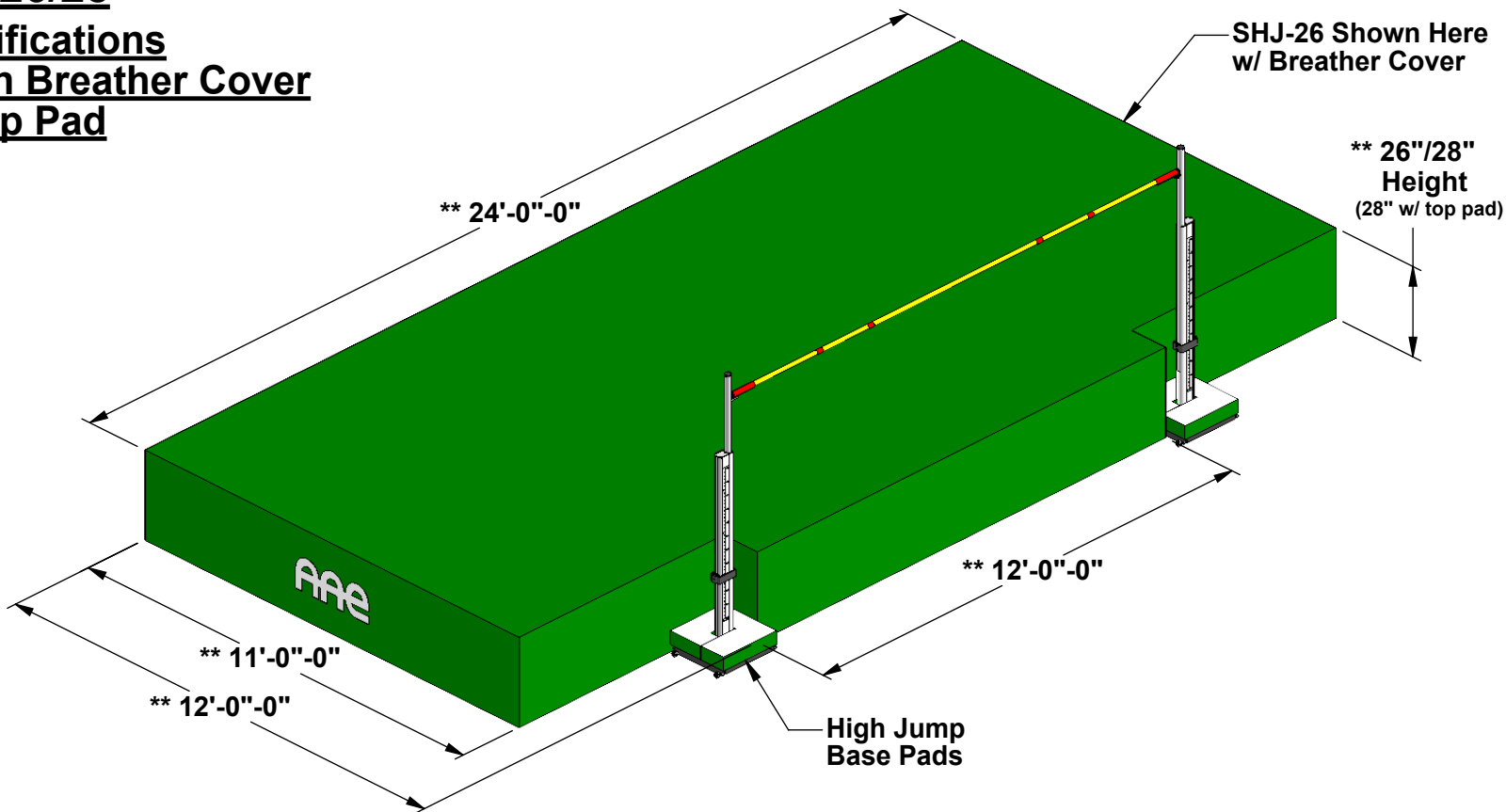

**\*\* Meets & Exceeds National Federation of State High School Associations & The National Collegiate Athletic Association's Ruling**



**Aluminum Athletic Equipment**  
 1000 Enterprise Drive, Royersford, PA 19468  
 Toll Free: (800) 523-5471 Fax: (610) 825-2378  
[www.AAEsports.com](http://www.AAEsports.com)

|   |                                   |                            |
|---|-----------------------------------|----------------------------|
| DESCRIPTION   |                                   |                            |
| <b>SHJ-26/28 Super High Jump Pad Specifications</b>     |                                   |                            |
| NOTE: Meets/Exceeds High School and NCAA Specifications |                                   |                            |
| MODEL: SHJ-26/28  | CATEGORY: CUSTOMER                | DATE: 2/28/02              |
| DRAWN BY: TAD   | CAD FILE: SHJ-26-28 Specs (Green) | DWG. NO. SHJ-26/28-C-100Gr |