

**AAE Model No. TB-15B-SP**  
**15' Semi-Permanent Team Bench with Backrest**

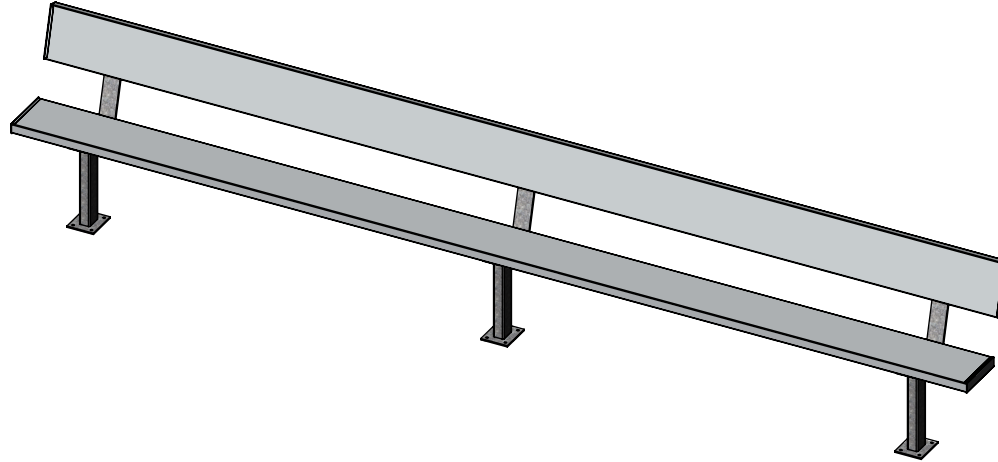

**Aluminum Athletic Equipment**  
1000 Enterprise Drive, Royersford, PA 19468  
Toll Free: (800) 523-5471 Fax: (610) 825-2378  
[www.AAEsports.com](http://www.AAEsports.com)

# TB-15B-SP - 15' Semi-Permanent Team Bench (with Backrest)

## Specifications

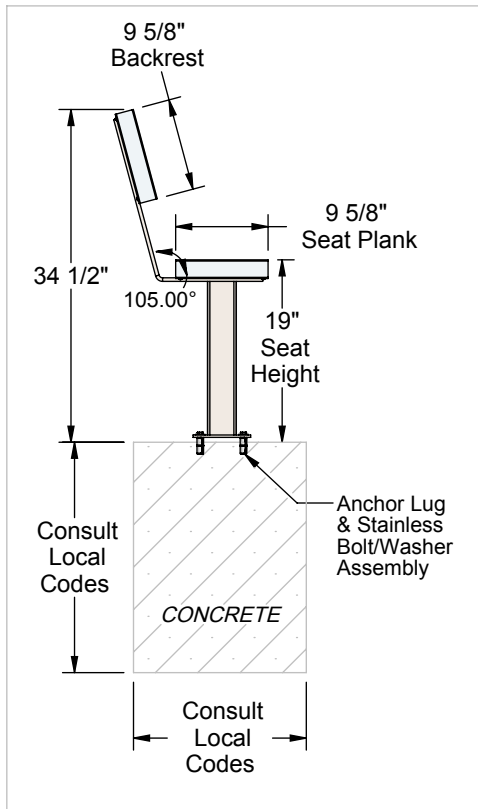

3" x 3/8" Galvanized Steel Bench Frame Welded to Bench Support Hot Dip Galvanized

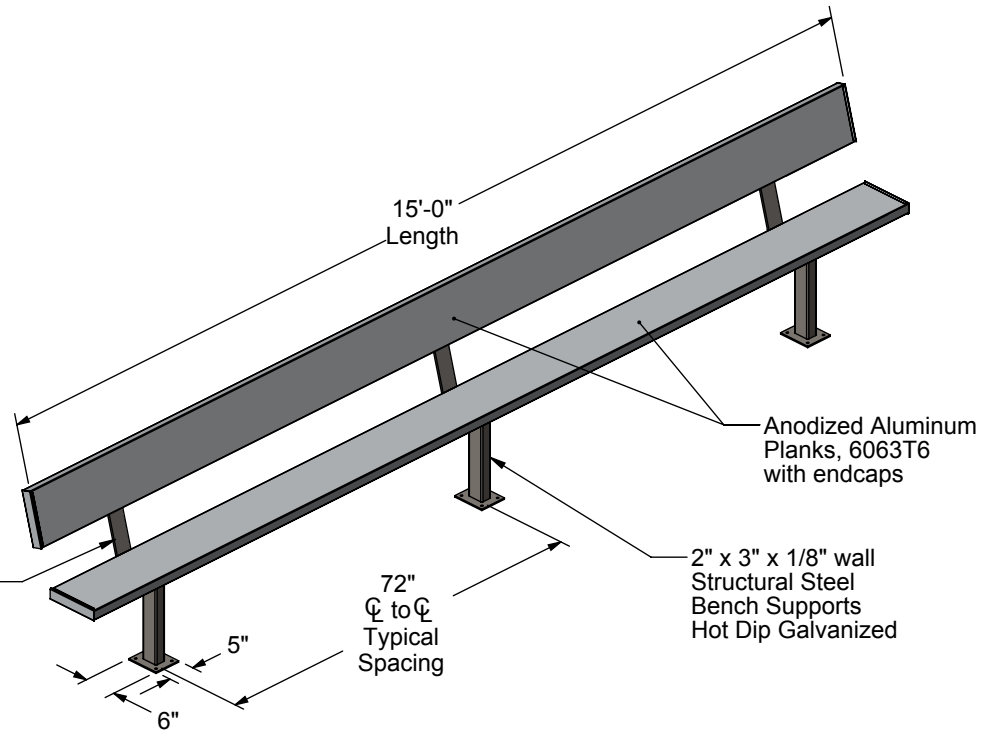

### Material Specifications

Materials: Anodized Aluminum, 6063T6  
Galvanized Steel Tube, 2" x 3" x 1/8" wall  
Galvanized Steel, 3/8" x 3" HRS  
Aluminum & Stainless Steel Hardware  
Concrete

Overall Weight: 115 lbs.  
Overall Size: 3' high x 2' deep x 15' long

\*AAE Warranty Standard\*



**Aluminum Athletic Equipment**  
1000 Enterprise Drive, Royersford, PA 19468  
Toll Free: (800) 523-5471 Fax: (610) 825-2378  
www.AAEsports.com

DESCRIPTION:		
<b>TB-15B-SP - Specifications</b>		
NOTE: 15' Semi-Permanent Team Bench with Backrest		
MODEL: TB-15B-SP	CATEGORY: <b>CUSTOMER</b>	DATE: 10/19/2018
DWN. BY: CED	CAD FILE: TB-15B-SP - Specifications	DWG. NO. TB-15B-SP-C-001