

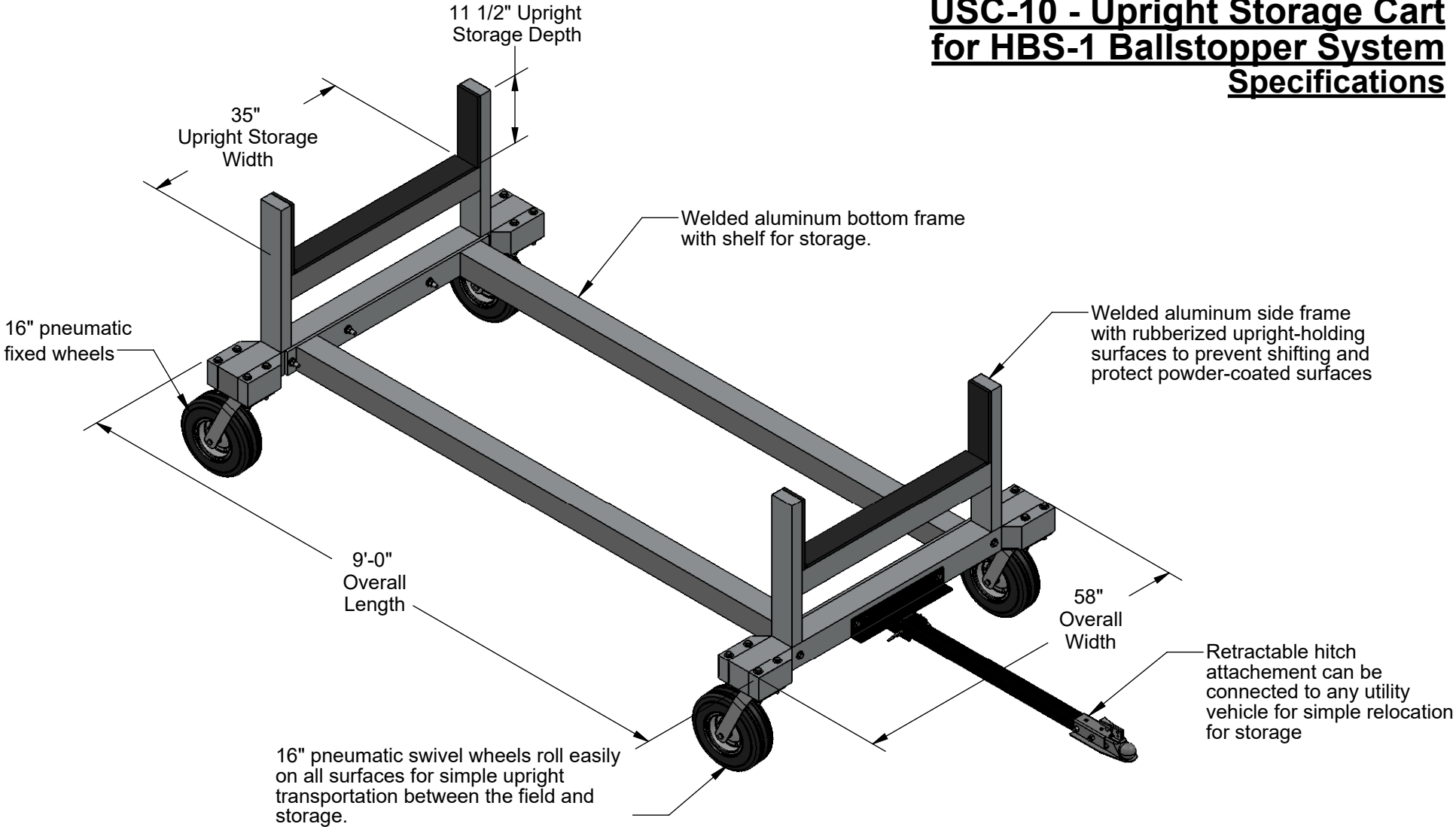

USC-10 - Upright Storage Cart for HBS-1 Ballstopper System Specifications



- Notes:**
- Designed for AAE Model No. HBS-1 Ground Sleeve Ballstopper System uprights
 - Can hold up to 56 HBS-1 uprights
 - 6 rubber strips included to place between layers of uprights (4 layers max.) to protect the surface finish
 - Always tie down and secure stored uprights before transporting them on the cart
 - Maximum load: 2000lbs.



Aluminum Athletic Equipment
1000 Enterprise Drive, Royersford, PA 19468
Toll Free: (800) 523-5471 Fax: (610) 825-2378
www.AAEsports.com

| | | |
|--|---------------------------------|-----------------------|
| DESCRIPTION: USC-10 - Specifications | | |
| NOTE: Upright Storage Cart for HBS-1 Ballstopper System Uprights | | |
| MODEL: USC-10 | CATEGORY: CUSTOMER | DATE: 09/30/11 |
| DWN. BY: CED | CAD FILE: USC-10 Specifications | DWG. NO. USC-10-C-001 |

| ITEM NO. | DESCRIPTION | QTY. |
|----------|-------------------------------------|------|
| 1 | USC-10 - Middle Brace | 1 |
| 2 | USC-10 - Side Frame | 2 |
| 3 | 16" Pneumatic Swivel Wheel | 2 |
| 4 | 16" Pneumatic Fixed Wheel | 2 |
| 5 | Hitch Assembly | 1 |
| 6 | 1/2"-13 x 5.5" L, Bolt, HDG | 16 |
| 7 | 1/2" Screw Size, Flat Washer, HDG | 56 |
| 8 | 1/2"-13, Hex Nut, w/ Ny-Lock Insert | 16 |
| 9 | 1/2"-13 Hex Nut, Steel, HDG | 8 |
| 10 | 1/2" Split-Lock Washer, Steel, HDG | 8 |
| 11 | 1/2"-13 x 6" L, Bolt | 8 |

USC-10 - Upright Storage Cart

Assembly Specifications

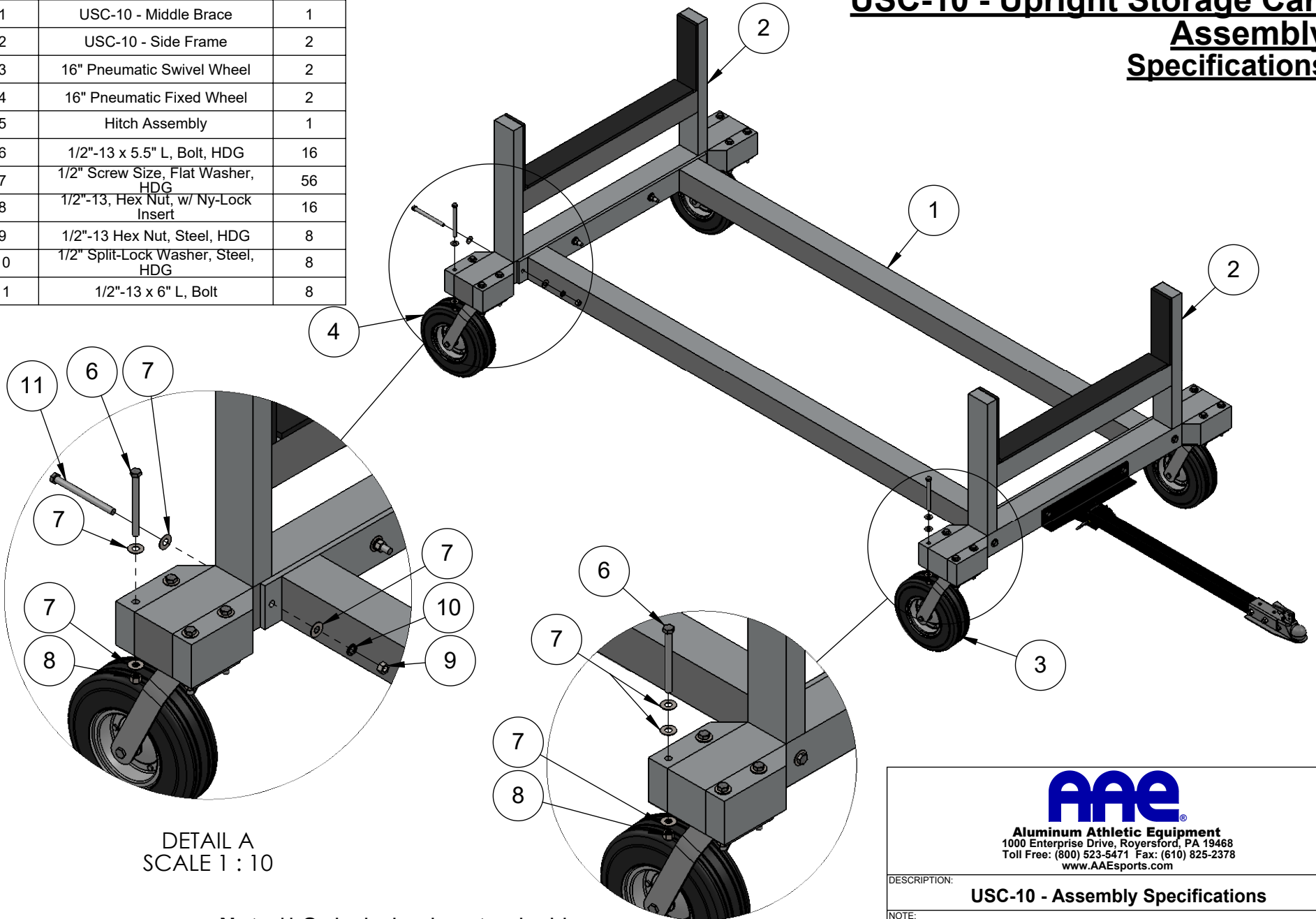

DETAIL A
SCALE 1 : 10

Note:** Swivel wheels get a double washer on top, (**Detail B**) to avoid wheel hitting bolts when rotating.

DETAIL B
SCALE 1 : 10



Aluminum Athletic Equipment
1000 Enterprise Drive, Royersford, PA 19468
Toll Free: (800) 523-5471 Fax: (610) 825-2378
www.AAEsports.com

| | | |
|---|-----------------------|--------------|
| DESCRIPTION: | | |
| USC-10 - Assembly Specifications | | |
| NOTE: Upright Storage Cart for HBS-1 Ballstopper System Uprights | | |
| MODEL: | CATEGORY: | DATE: |
| USC-10 | CUSTOMER | 12/01/2023 |
| DWN. BY: | CAD FILE: | DWG. NO.: |
| CED | USC-10 Specifications | USC-10-C-002 |