

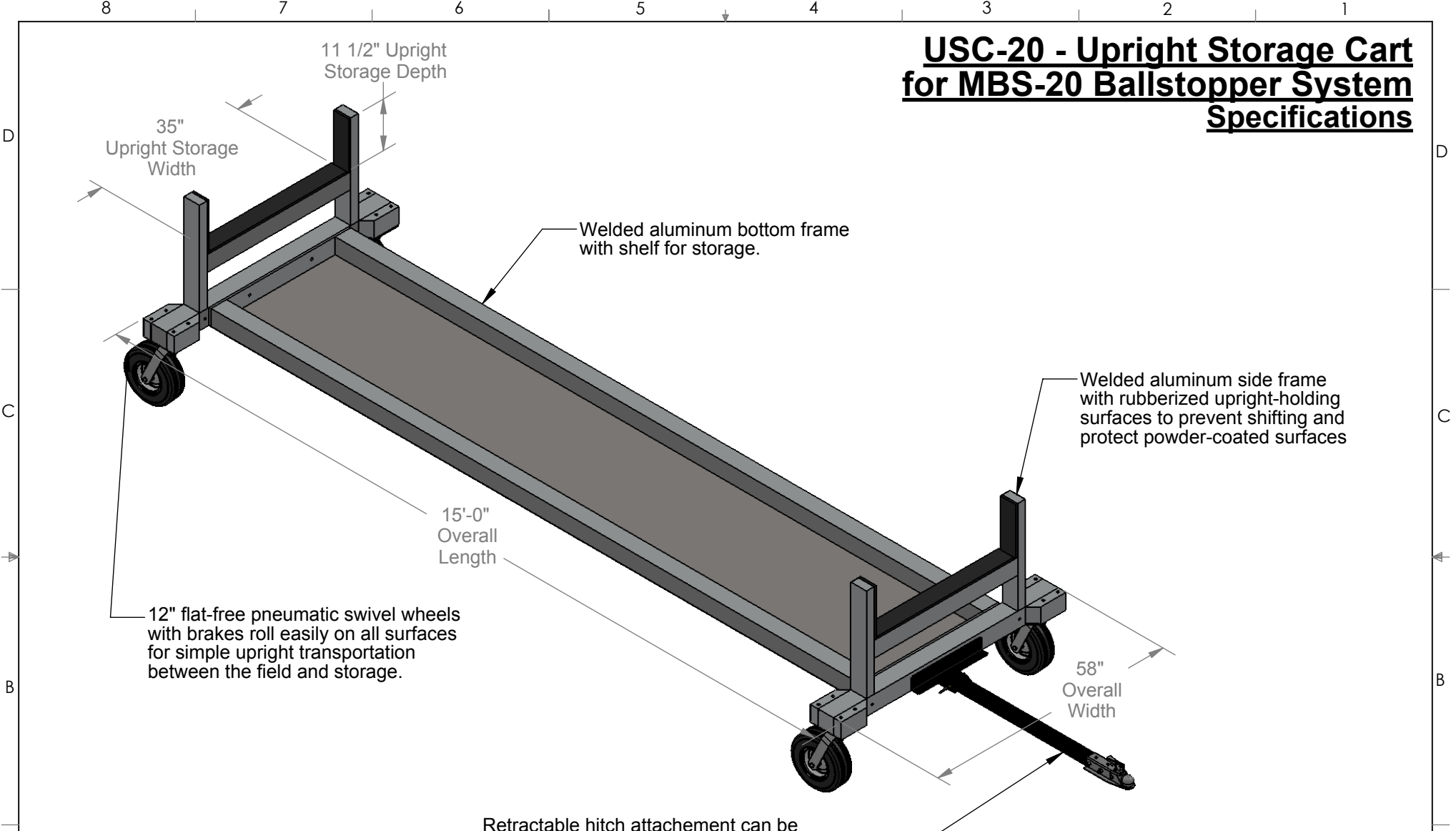

USC-20 - Upright Storage Cart for MBS-20 Ballstopper System Specifications



Notes:

- Designed for AAE Model No. MBS-20 or SBS-20 Ballstopper System uprights
- Can hold up to 24 MBS-20 or SBS-20 uprights
- 4 rubber strips included to place between layers of uprights (3 layers max.) to protect the surface finish
- Always tie down and secure stored uprights before transporting them on the cart
- Maximum load: 2000lbs.



Aluminum Athletic Equipment
1000 Enterprise Drive, Royersford, PA 19468
Toll Free: (800) 523-5471 Fax: (610) 825-2378
www.AAEsports.com

DESCRIPTION: USC-20 - Specifications		
NOTE: Upright Storage Cart for MBS-20 Ballstopper System Uprights		
MODEL: USC-20	CATEGORY: CUSTOMER	DATE: 09/30/11
DWN. BY: ARP	CAD FILE: USC-20 Specifications	DWG. NO. USC-20-C-001