

USC-30 - Upright Storage Cart for MBS-30 Ballstopper System Specifications

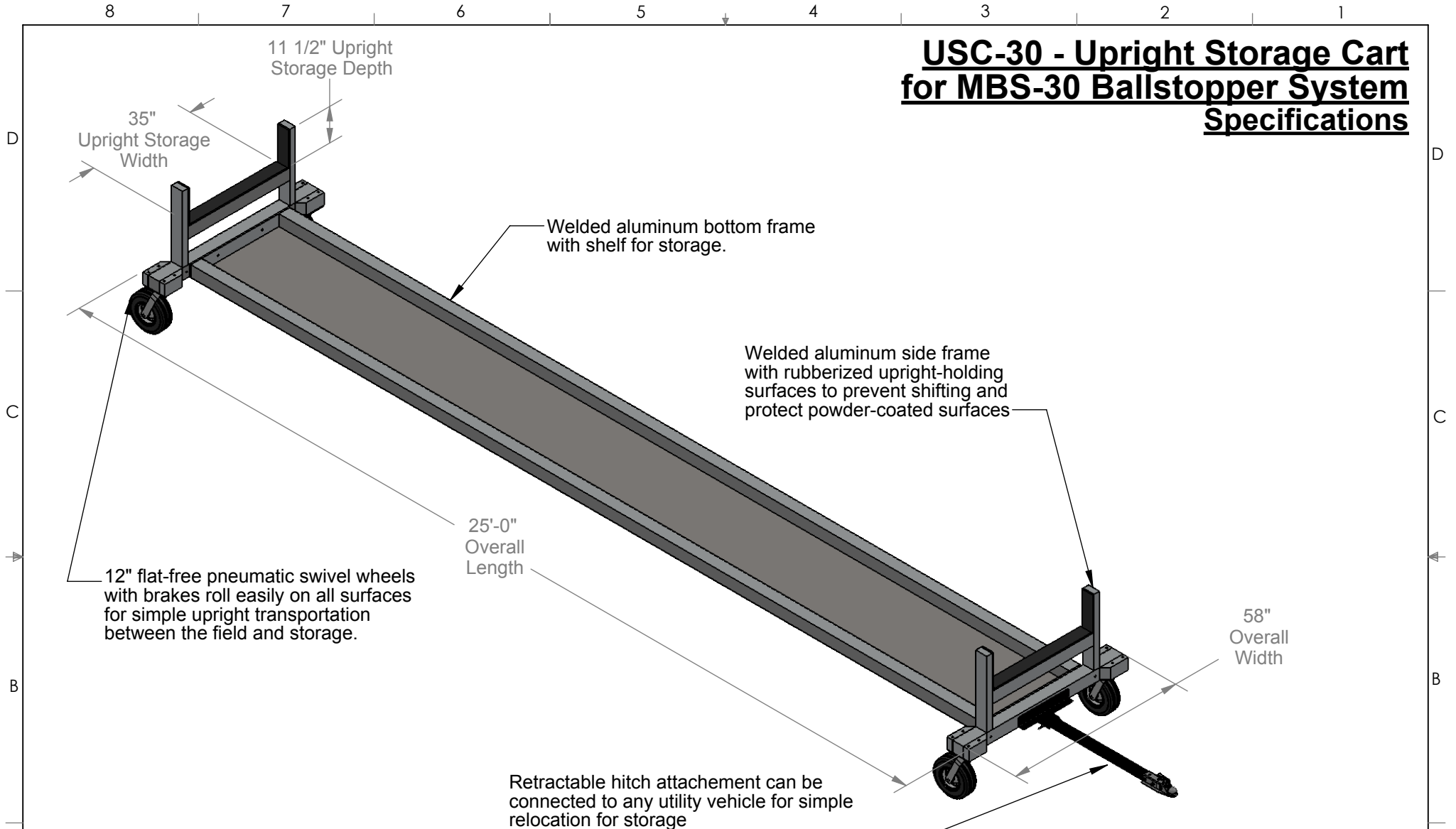

Notes:

- Designed for AAE Model No. MBS-30 Ballstopper System uprights
- Can hold up to 10 MBS-30 uprights
- 2 rubber strips included to place between layers of uprights (2 layers max.) to protect the surface finish
- Always tie down and secure stored uprights before transporting them on the cart
- Maximum load: 2000lbs.



Aluminum Athletic Equipment
1000 Enterprise Drive, Royersford, PA 19468
Toll Free: (800) 523-5471 Fax: (610) 825-2378
www.AAEsports.com

DESCRIPTION: USC-30 - Specifications		
NOTE: Upright Storage Cart for MBS-30 Ballstopper System Uprights		
MODEL: USC-30	CATEGORY: CUSTOMER	DATE: 09/30/11
DWN. BY: ARP	CAD FILE: USC-30 Specifications	DWG. NO. USC-30-C-001