

Model No.: XLAH-CP

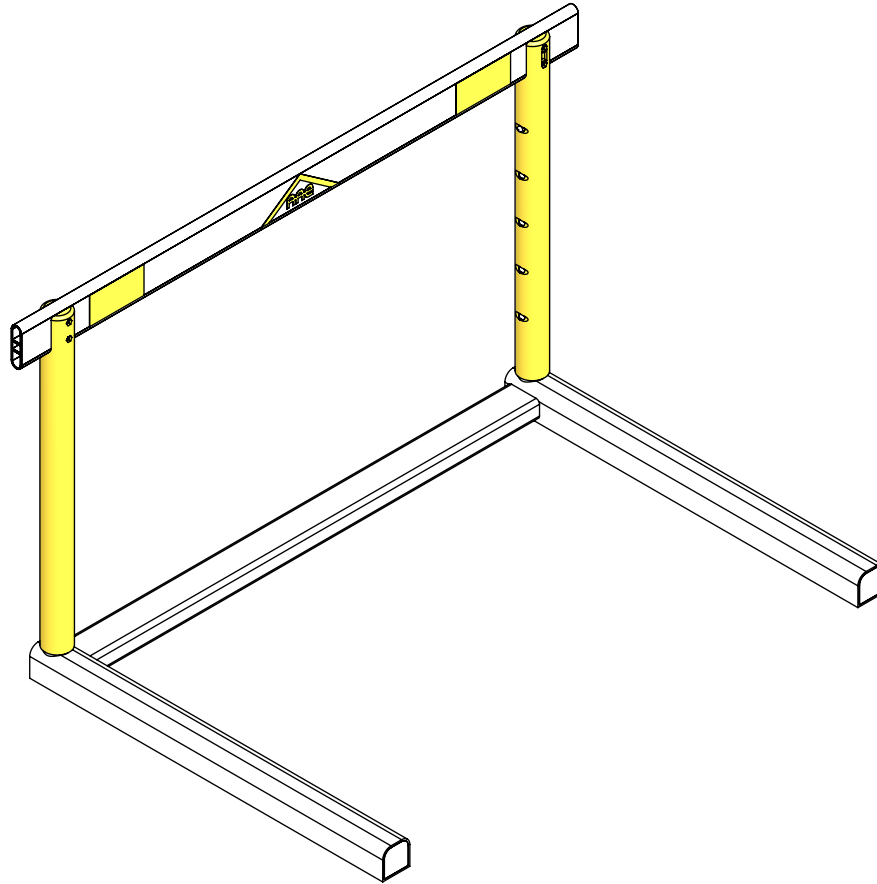

Aluminum Athletic Equipment
1000 Enterprise Drive, Royersford, PA 19468
Toll Free: (800) 523-5471 Fax: (610) 825-2378
www.AAEsports.com

XLAH-CP - Specifications

High School 90° Competition/Practice Hurdle

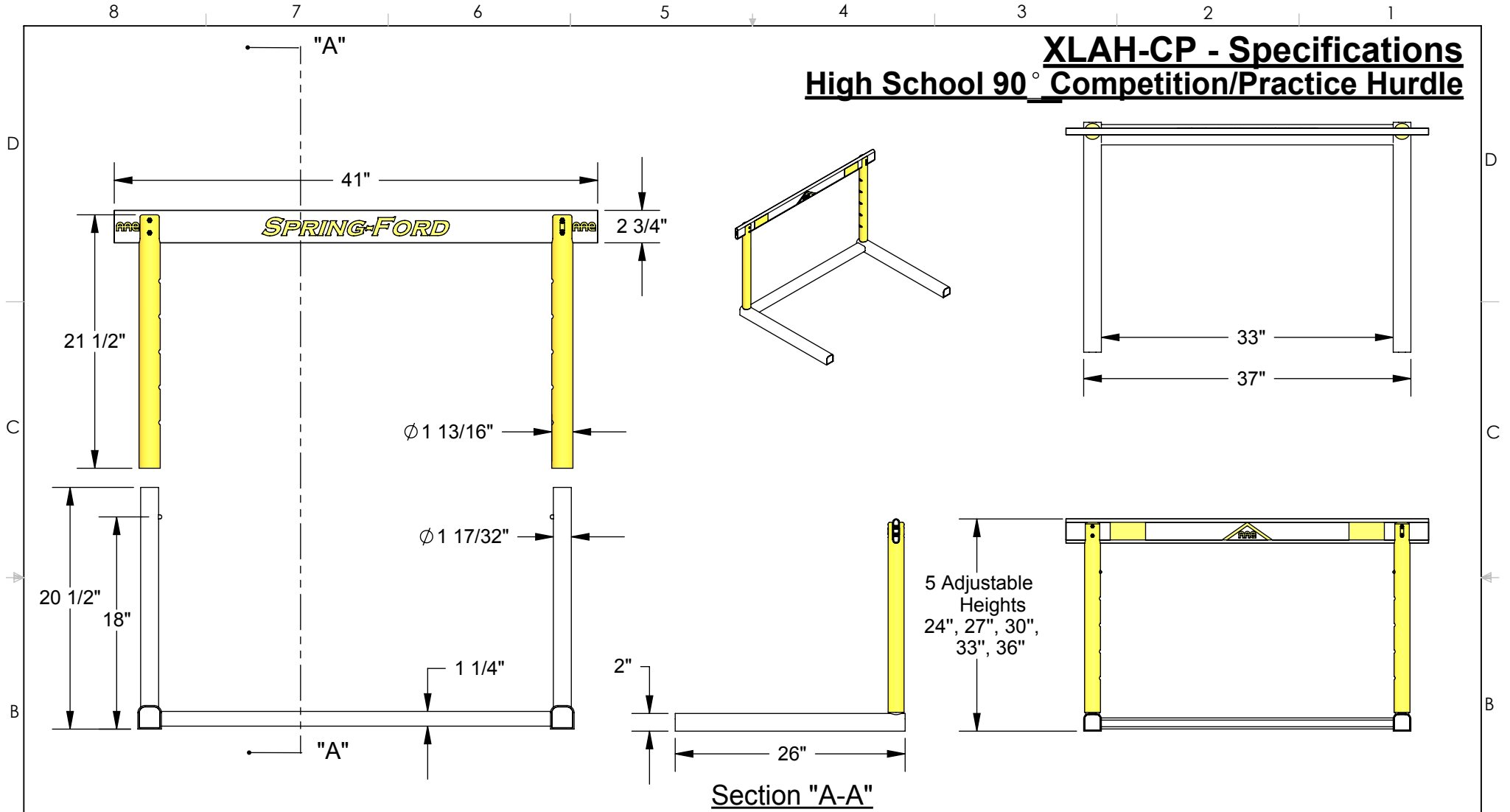

FEATURES:

- * Meets all NFHS Specifications
- * All aluminum, super-strong, welded base, 6061T6 alloy
- * Double-web Lexan board with school name or logo
- * Center mounted, "vise gripped" hurdle board
- * Recessed, low profile, stainless steel hurdle board hardware
- * Durable UV-stabilized polycarbonate tubes in color of choice
- * Self-adjusting counter-balance weights, galvanized steel (rust-free)
- * Reinforced hurdle uprights for maximum strength
- * Rounded corners on all parts for added safety
- * AAE standard life-time warranty

* Official Equipment Supplier of The ZENN RELAYS



Aluminum Athletic Equipment
 1000 Enterprise Drive, Royersford, PA 19468
 Toll Free: (800) 523-5471 Fax: (610) 825-2378
www.AAEsports.com

DESCRIPTION		
XLAH-CP - Specifications		
NOTE: High School 90° Competition/Practice Hurdle		
MODEL: XLAH-CP	CATEGORY: CUSTOMER	DATE: 10/11/11
DRAWN BY: ARP	CAD FILE: XLAH-CP Packet	DWG. NO. XLAH-CP-C-001

XLAH-CP - Assembly

F
E
D
C
B
A

F
E
D
C
B
A

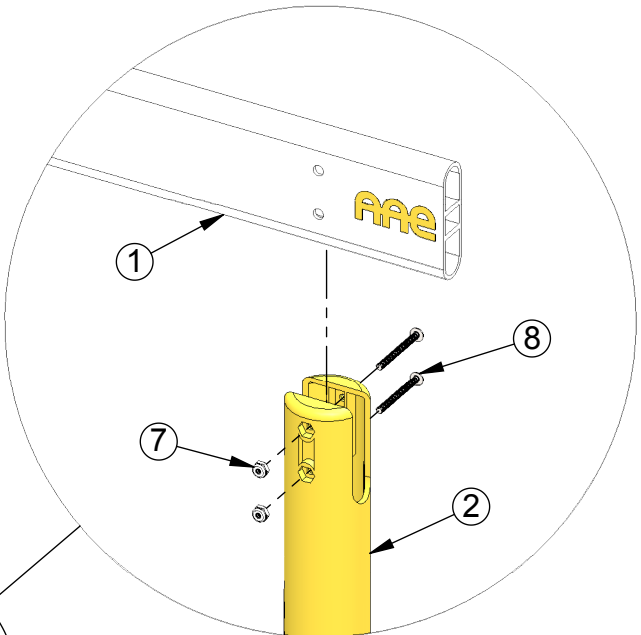
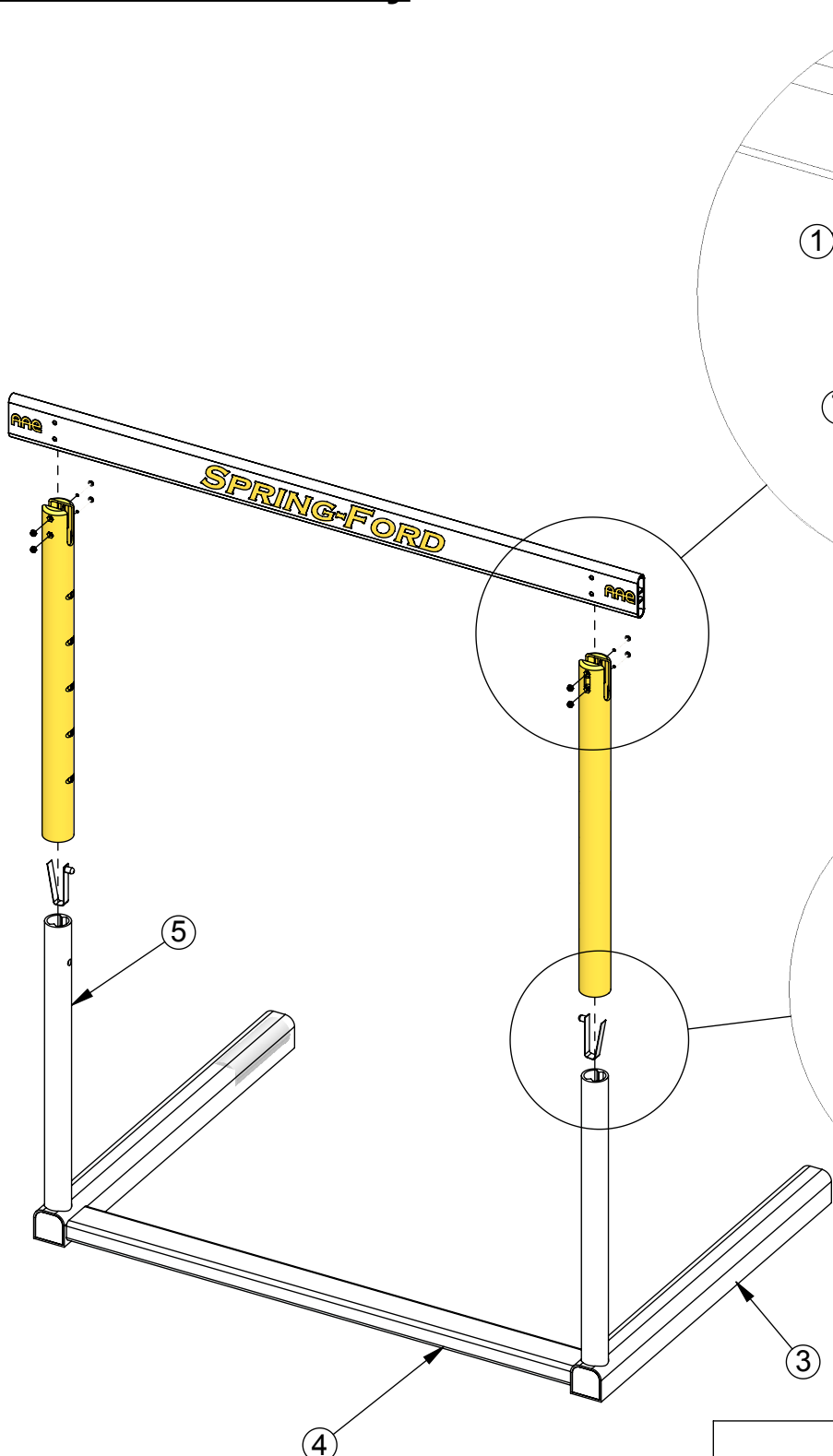

DETAIL A
SCALE 1 : 4

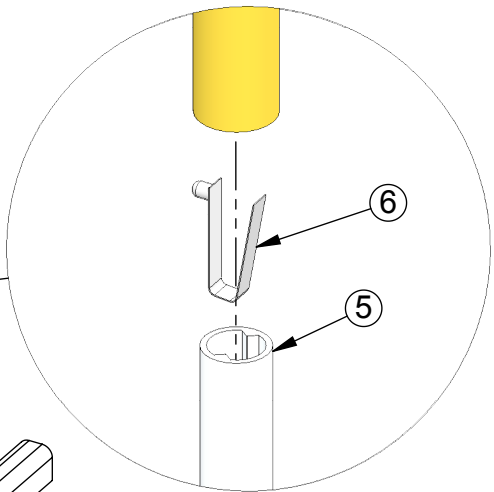

DETAIL B
SCALE 1 : 4



Aluminum Athletic Equipment
1000 Enterprise Drive, Royersford, PA 19468
Toll Free: (800) 523-5471 Fax: (610) 825-2378
www.AAEsports.com

DESCRIPTION:		
XLAH-CP - Assembly		
NOTE: High School 90° Competition/Practice Hurdle		
MODEL: XLAH-CP	CATEGORY: CUSTOMER	DATE: 10/11/11
DWN. BY: ARP	CAD FILE: XLAH-CP Packet	DWG. NO. XLAH-CP-C-002

6 | 5 | 4 | 3 | 2 | 1