

Model No.: XLAH-HS

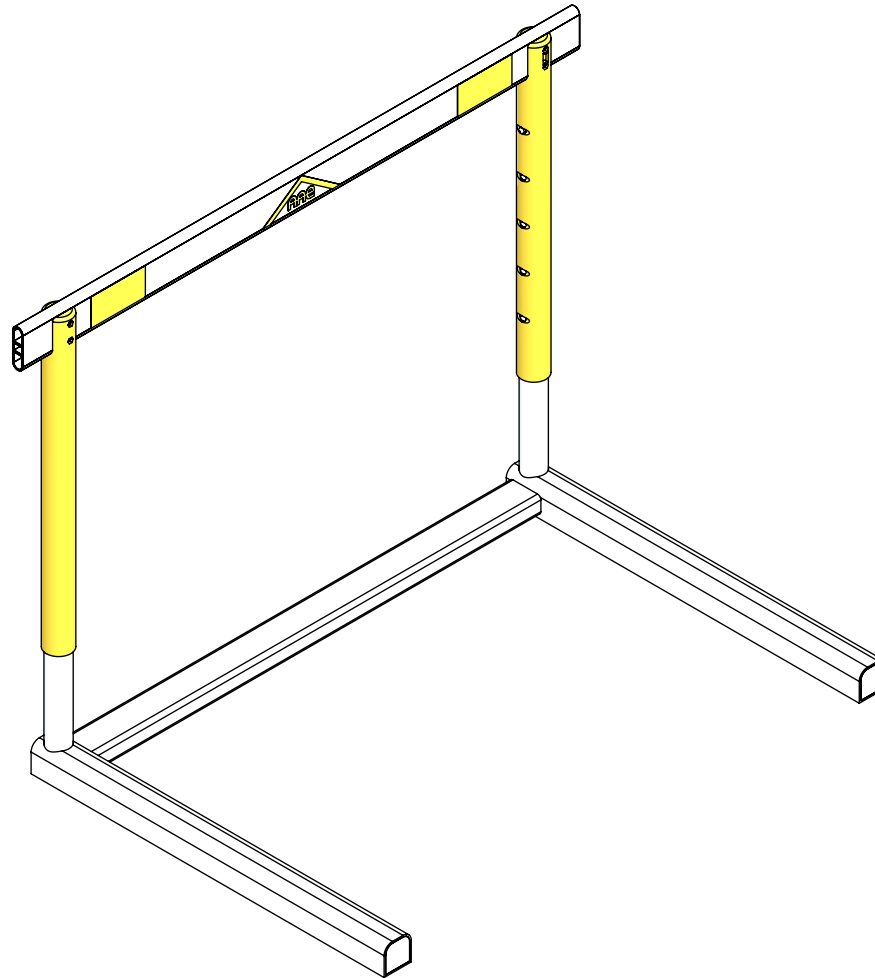

Aluminum Athletic Equipment
1000 Enterprise Drive, Royersford, PA 19468
Toll Free: (800) 523-5471 Fax: (610) 825-2378
www.AAEsports.com

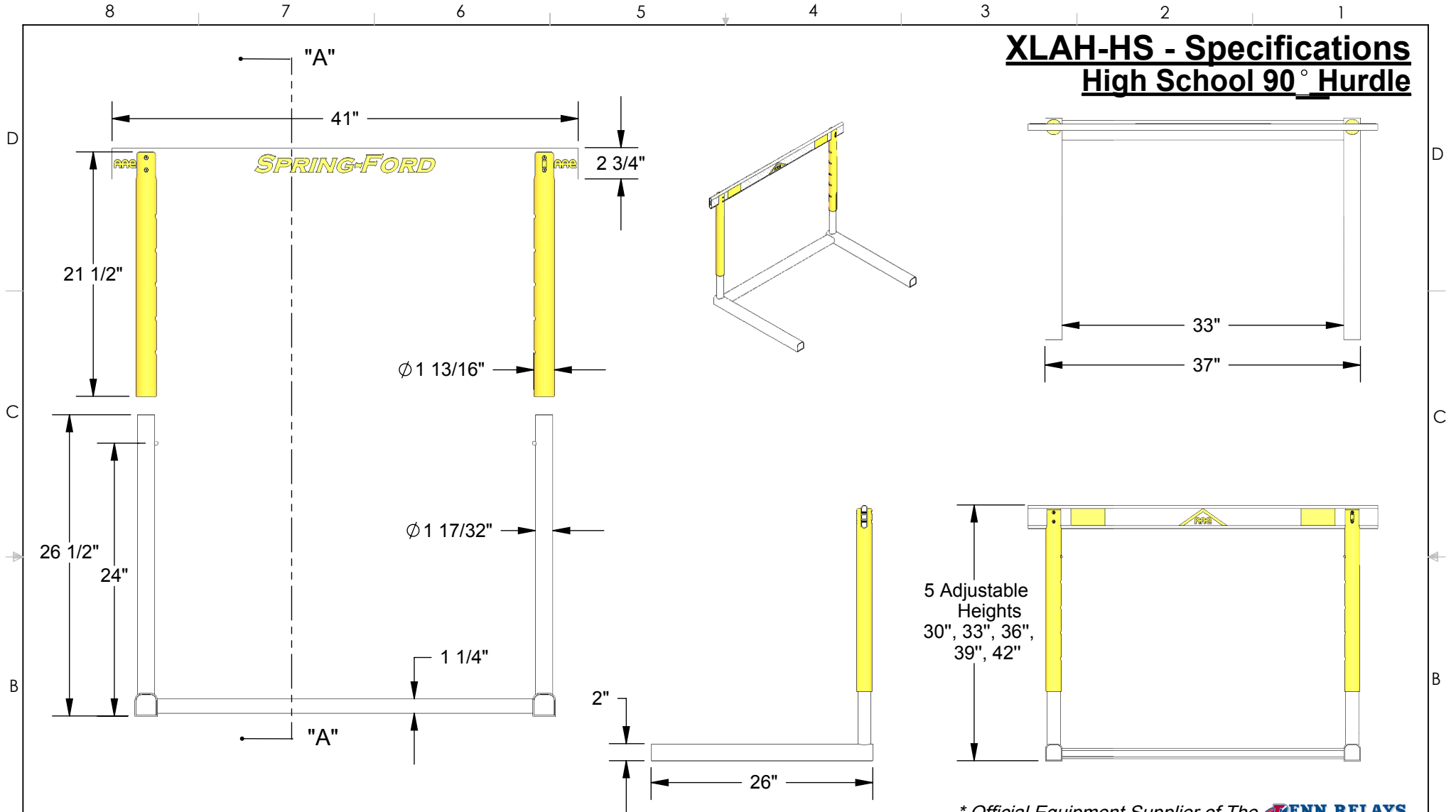

XLAH-HS - Specifications

High School 90° Hurdle

FEATURES:

- * Meets all NFHS Specifications
- * All aluminum, super-strong, welded base, 6061T6 alloy
- * Double-web Lexan board with school name or logo
- * Center mounted, "vise gripped" hurdle board
- * Recessed, low profile, stainless steel hurdle board hardware
- * Durable UV-stabilized polycarbonate tubes in color of choice
- * Self-adjusting counter-balance weights, galvanized steel (rust-free)
- * Reinforced hurdle uprights for maximum strength
- * Rounded corners on all parts for added safety
- * AAE standard life-time warranty

5 Adjustable Heights
30", 33", 36", 39", 42"

* Official Equipment Supplier of The ZENN RELAYS

 Aluminum Athletic Equipment 1000 Enterprise Drive, Royersford, PA 19468 Toll Free: (800) 523-5471 Fax: (610) 825-2378 www.AAEsports.com		
DESCRIPTION		
XLAH-HS - Specifications		
NOTE: High School 90° Hurdle		
MODEL: XLAH-HS	CATEGORY: CUSTOMER	DATE: 10/11/11
DRAWN BY: ARP	CAD FILE: XLAH-HS Packet	DWG. NO. XLAH-HS-C-001

XLAH-HS - Assembly

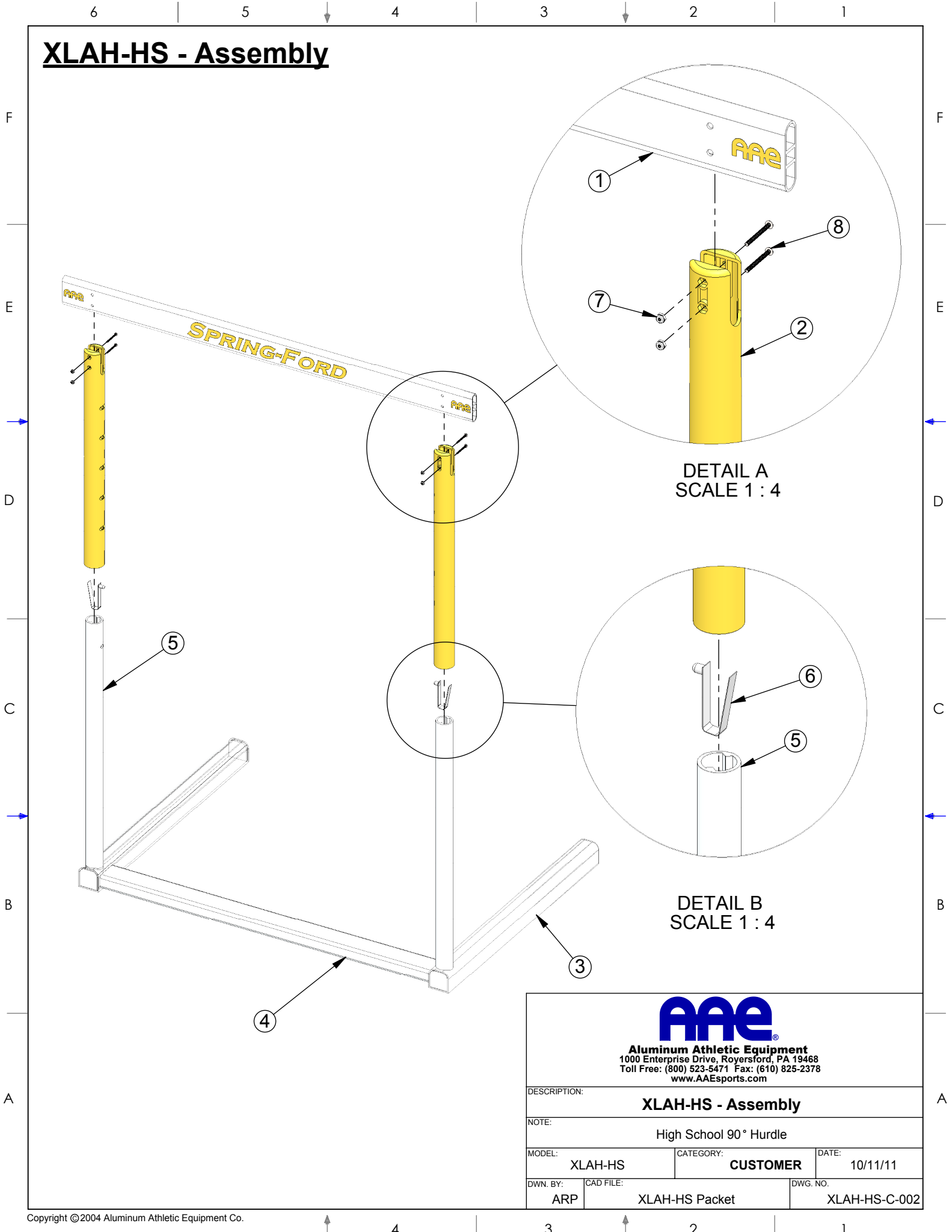

DETAIL A
SCALE 1 : 4

DETAIL B
SCALE 1 : 4



Aluminum Athletic Equipment
1000 Enterprise Drive, Royersford, PA 19468
Toll Free: (800) 523-5471 Fax: (610) 825-2378
www.AAEsports.com

DESCRIPTION:			XLAH-HS - Assembly		
NOTE:			High School 90° Hurdle		
MODEL:	XLAH-HS	CATEGORY:	CUSTOMER	DATE:	10/11/11
DWN. BY:	ARP	CAD FILE:	XLAH-HS Packet	DWG. NO.:	XLAH-HS-C-002