

Model No.: XLAH-II

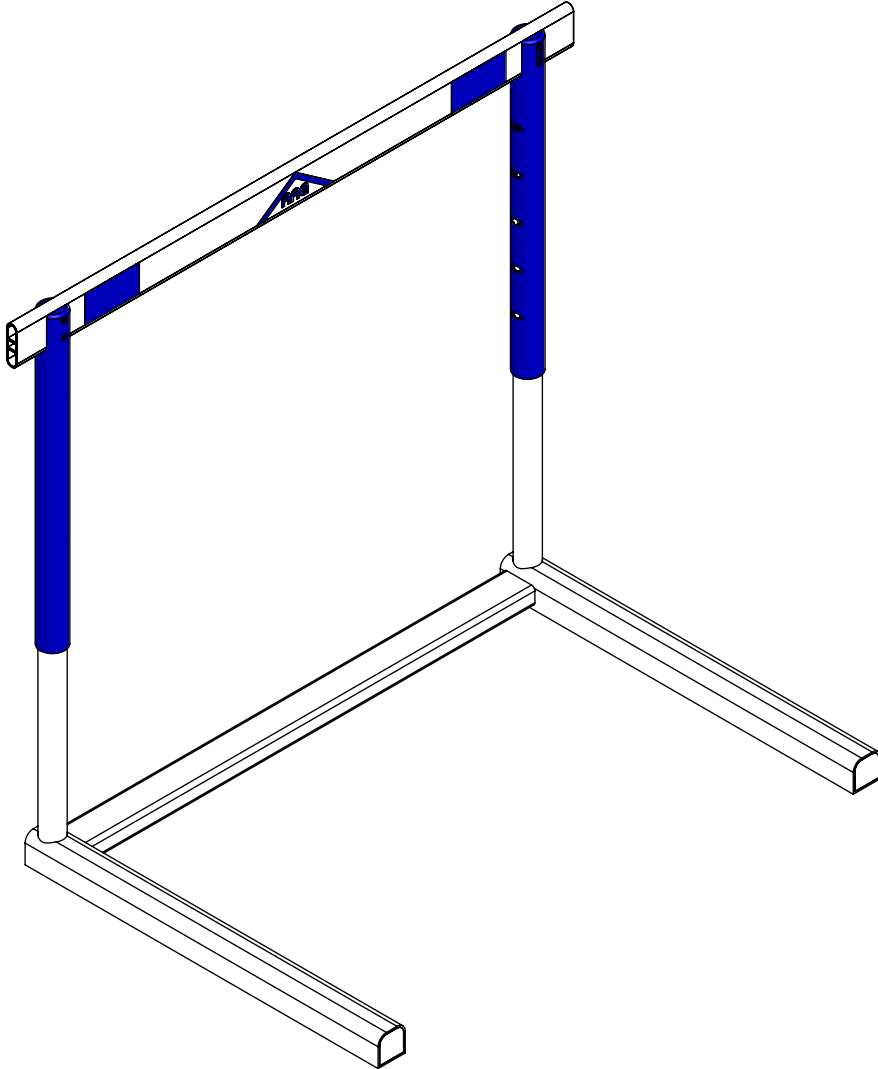

Aluminum Athletic Equipment
1000 Enterprise Drive, Royersford, PA 19468
Toll Free: (800) 523-5471 Fax: (610) 825-2378
www.AAEsports.com

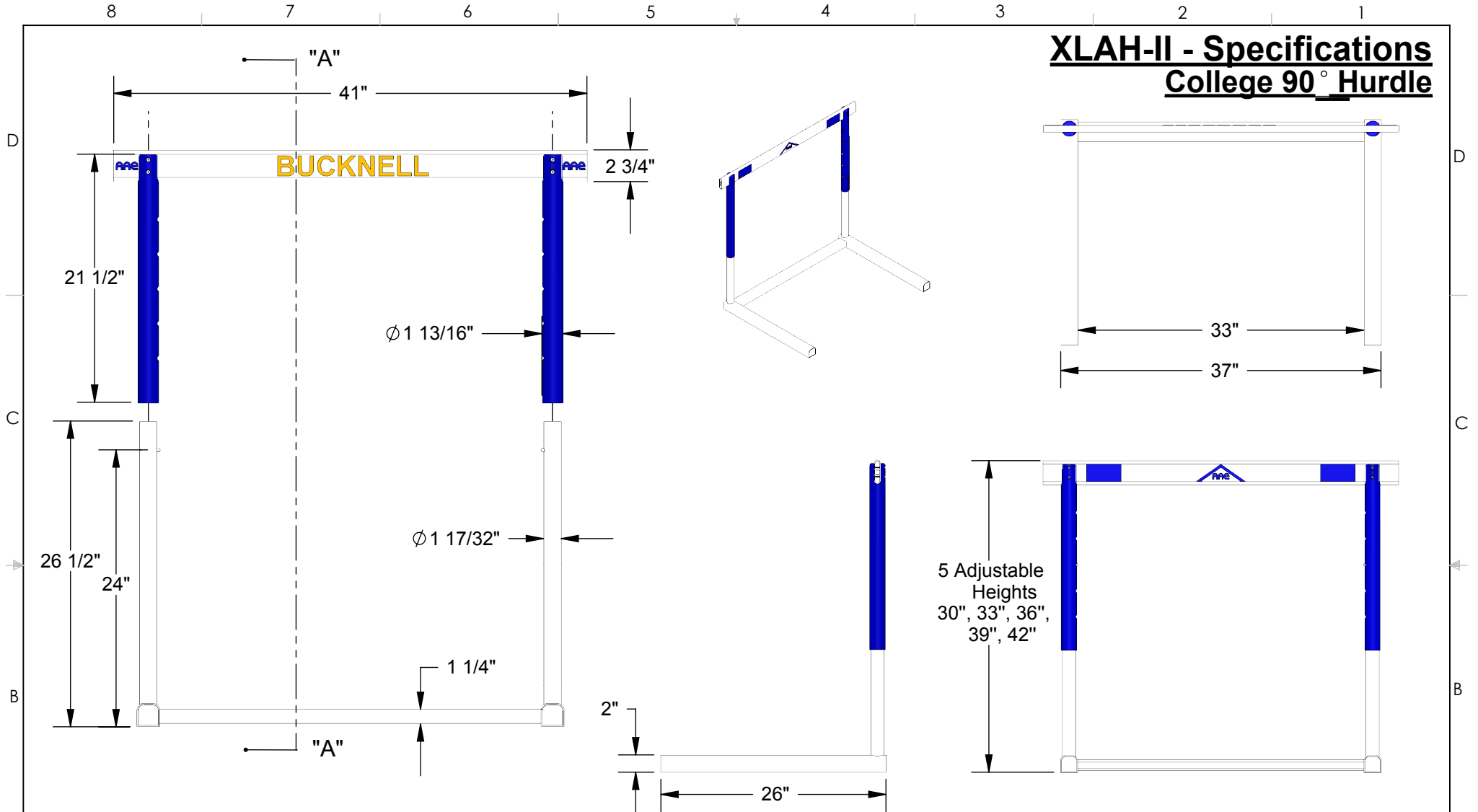

XLAH-II - Specifications

College 90° Hurdle

FEATURES:

- * Meets all NCAA and NFHS Specifications
- * All aluminum, super-strong, welded base, 6061T6 alloy
- * Double-web Lexan board with school name or logo
- * Center mounted, "vise gripped" hurdle board
- * Recessed, low profile, stainless steel hurdle board hardware
- * Durable UV-stabilized polycarbonate tubes in color of choice
- * Fixed counter-balance weights, galvanized steel (rust-free)
- * Reinforced hurdle uprights for maximum strength
- * Rounded corners on all parts for added safety
- * XLAH-II-47: 47" wide model available for wider lanes
- * AAE standard life-time warranty

5 Adjustable Heights
30", 33", 36",
39", 42"

* Official Equipment Supplier of The ZENN RELAYS

 Aluminum Athletic Equipment 1000 Enterprise Drive, Royersford, PA 19468 Toll Free: (800) 523-5471 Fax: (610) 825-2378 www.AAEsports.com		
DESCRIPTION		
XLAH-II - Specifications		
NOTE: College 90° Hurdle		
MODEL: XLAH-II	CATEGORY: CUSTOMER	DATE: 10/11/11
DRAWN BY: ARP	CAD FILE: XLAH-II Packet	DWG. NO. XLAH-II-C-001

XLAH-II - Assembly

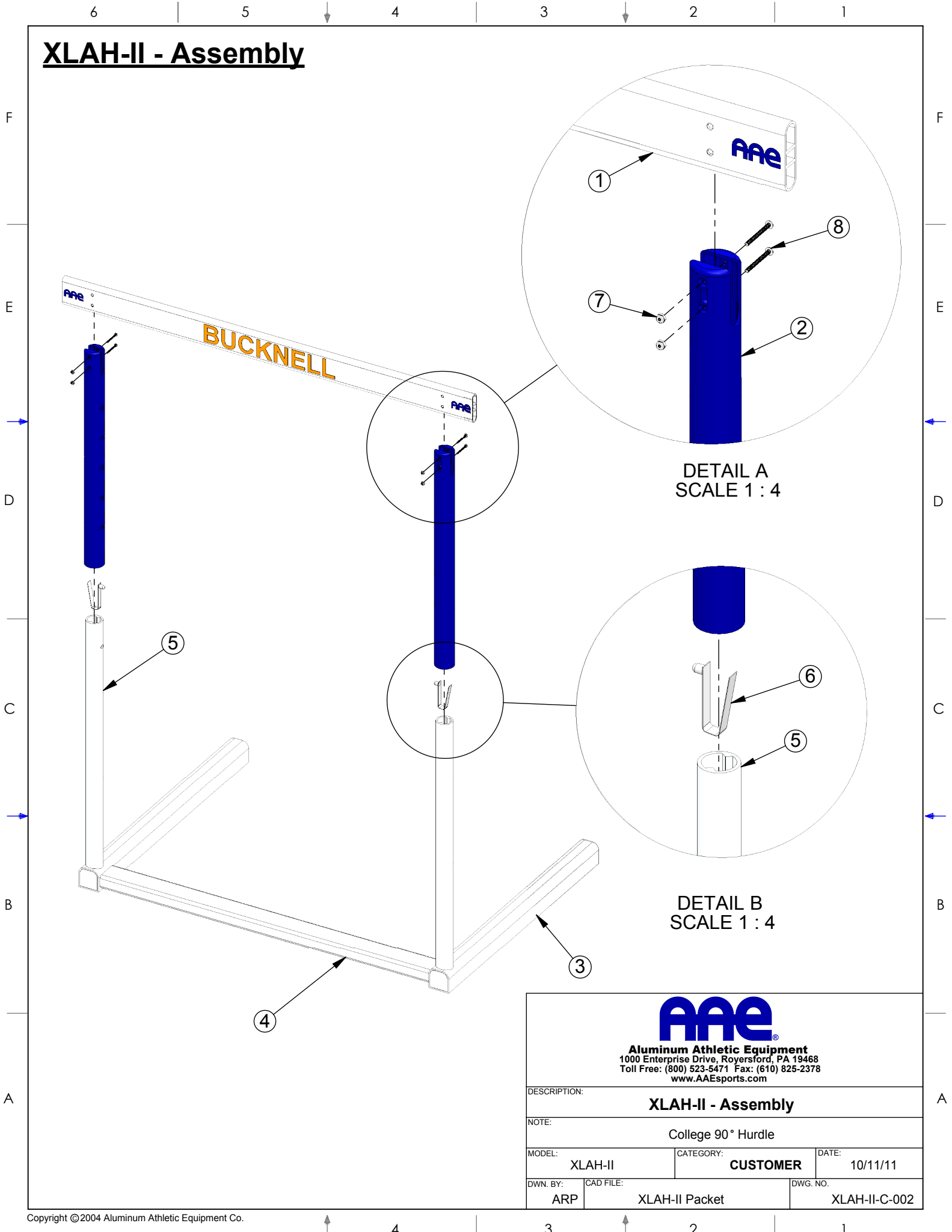

DETAIL A
SCALE 1 : 4

DETAIL B
SCALE 1 : 4



Aluminum Athletic Equipment
1000 Enterprise Drive, Royersford, PA 19468
Toll Free: (800) 523-5471 Fax: (610) 825-2378
www.AAEsports.com

DESCRIPTION:		
XLAH-II - Assembly		
NOTE:		
College 90° Hurdle		
MODEL:	CATEGORY:	DATE:
XLAH-II	CUSTOMER	10/11/11
DWN. BY:	CAD FILE:	DWG. NO.:
ARP	XLAH-II Packet	XLAH-II-C-002